

Chapter 16 I2S/PCM Controller (8 channel)

16.1 Overview

The I2S/PCM controller is designed for interfacing between the AHB bus and the I2S bus.

The I2S bus (Inter-IC sound bus) is a serial link for digital audio data transfer between devices in the system and be invented by Philips Semiconductor. Now it is widely used by many semiconductor manufacturers.

Devices often use the I2S bus are ADC, DAC, DSP, CPU, etc. With the I2S interface, we can connect audio devices and the embedded SoC platform together and provide an audio interface solution for the system.

Not only I2S but also PCM mode surround audio output (up to 7.1channel) and stereo input are supported in I2S/PCM controller.

- Support five internal 32-bit wide and 32-location deep FIFOs, four for transmitting and one for receiving audio data
- Support AHB bus interface
- Support 16 ~ 32 bits audio data transfer
- Support master and slave mode
- Support DMA handshake interface and configurable DMA water level
- Support transmit FIFO empty, underflow, receive FIFO full, overflow interrupt and all interrupts can be masked
- Support configurable water level of transmit FIFO empty and receive FIFO full interrupt
- Support combine interrupt output
- Support 2,4,6,8 channels audio transmitting in I2S and PCM mode
- Support 2 channels audio receiving in I2S and PCM mode
- Support up to 192kHz sample rate
- Support I2S normal, left and right justified mode serial audio data transfer
- Support PCM early, late1, late2, late3 mode serial audio data transfer
- Support MSB or LSB first serial audio data transfer
- Support 16 to 31 bit audio data left or right justified in 32-bit wide FIFO
- Support two 16-bit audio data store together in one 32-bit wide location
- Support 3 independent LRCK signals, one for receiving and two for transmitting audio data
- Support configurable SCLK and LRCK polarity
- Support SCLK is equivalent to MCLK divided by an even number range from 2 to 64 in master mode

16.2 Block Diagram

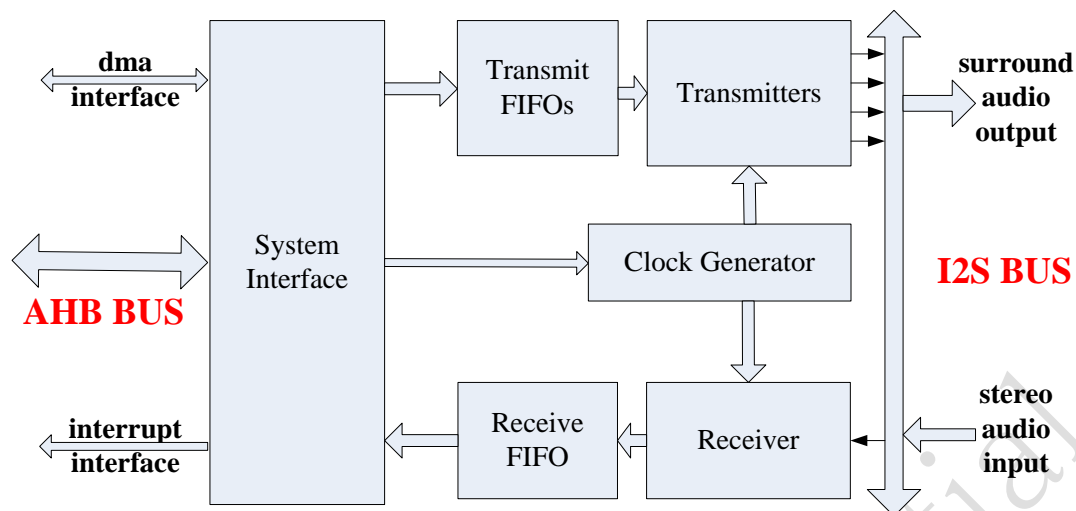

Fig. 16-1 I2S/PCM controller (8 channel) Block Diagram

System Interface

The system interface implements the AHB slave operation. It contains not only control registers of transmitters and receiver inside but also interrupt and DMA handshake interface.

Clock Generator

The Clock Generator implements clock generation function. The input source clock to the module is MCLK_I2S, and by the divider of the module, the clock generator generates SCLK and LRCK to transmitter and receiver.

Transmitters

The Transmitters implement transmission operation. The transmitters can act as either master or slave, with I2S or PCM mode surround (up to 7.1 channel) serial audio interface.

Receiver

The Receiver implements receive operation. The receiver can act as either master or slave, with I2S or PCM mode stereo serial audio interface.

Transmit FIFOs

The Transmit FIFOs are the buffer to store transmitted audio data. Each of the size of the four FIFOs is 32bits x 32.

Receive FIFO

The Receive FIFO is the buffer to store received audio data. The size of the FIFO is 32bits x 32.

16.3 Function description

In the I2S/PCM controller, there are four conditions: transmitter-master & receiver-master; transmitter-master & receiver-slave; transmitter-slave & receiver-master; transmitter-slave & receiver-slave.

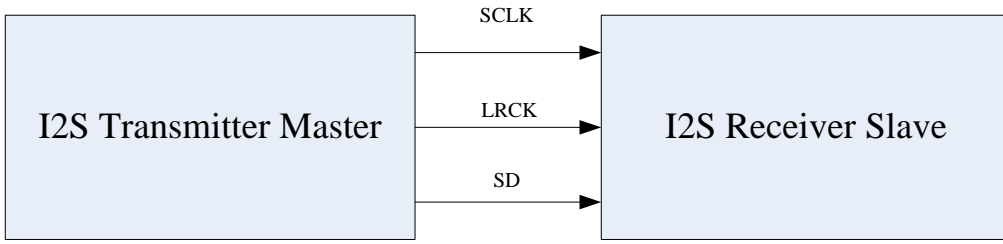

Fig. 16-2 I2S transmitter-master & receiver-slave condition

When transmitter acts as a master, it sends all signals to receiver (slave), and CPU control when to send clock and data to the receiver. When acting as a slave, SD signal still goes from transmitter to receiver, but SCLK and LRCK signals are from receiver (master) to transmitter. Based on three interface specifications, transmitting data should be ready before transmitter receives SCLK and LRCK signals. CPU should know when the receiver to initialize a transaction and when to send data.

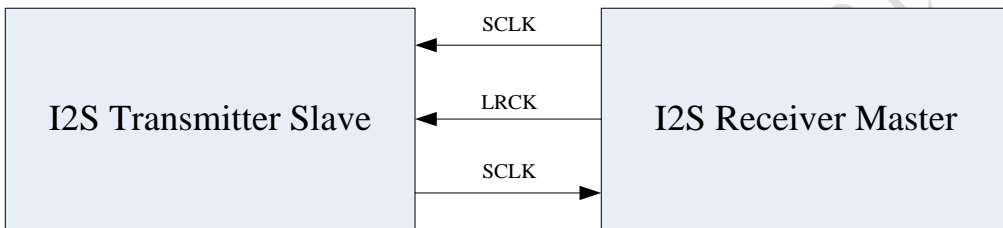

Fig. 16-3 I2S transmitter-slave& receiver-master condition

When the receiver acts as a master, it sends SCLK and LRCK signals to the transmitter (slave) and receives serial data. So CPU must tell the transmitter when to start a transaction for it to prepare transmitting data then start a transfer and send clock and channel-select signals. When the receiver acts as a slave, CPU should only do initial setting and wait for all signals and then start reading data.

Before transmitting or receiving data, CPU need do initial setting to the I2S register. These includes CPU settings, I2S interface registers settings, and maybe the embedded SoC platform settings. These registers must be set before starting data transfer.

16.3.1 i2s normal mode

This is the waveform of I2S normal mode. For LRCK (i2s_lrck_rx/i2s_lrck_tx0) signal, it goes low to indicate left channel and high to right channel. For SD (i2s_sdo0, i2s_sdo1, i2s_sdo2, i2s_sdo3, i2s_sdi) signal, it transfers MSB or LSB first and sends the first bit one SCLK clock cycle after LRCK changes. The range of SD signal width is from 16 to 32bits.

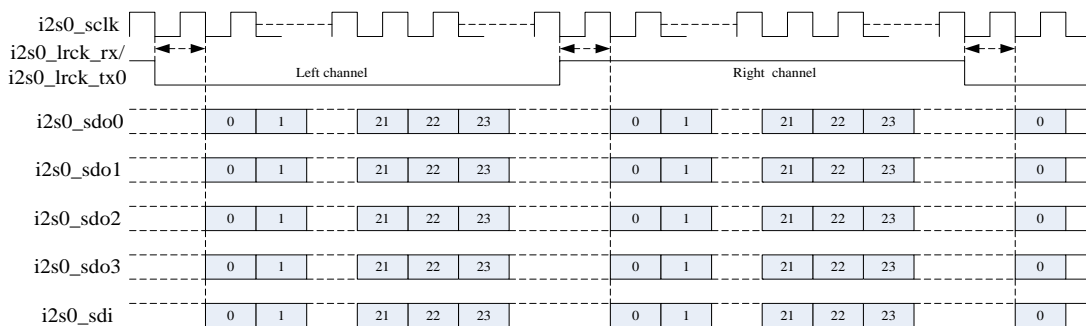

Fig. 16-4 I2S normal mode timing format

16.3.2 i2s left justified mode

This is the waveform of I2S left justified mode. For LRCK (i2s_lrck_rx / i2s_lrck_tx0) signal, it goes high to indicate left channel and low to right channel. For SD (i2s_sdo0, i2s_sdo1, i2s_sdo2, i2s_sdo3, i2s_sdi) signal, it transfers MSB or LSB first and sends the first bit at the same time when LRCK changes. The range of SD signal width is from 16 to 32bits.

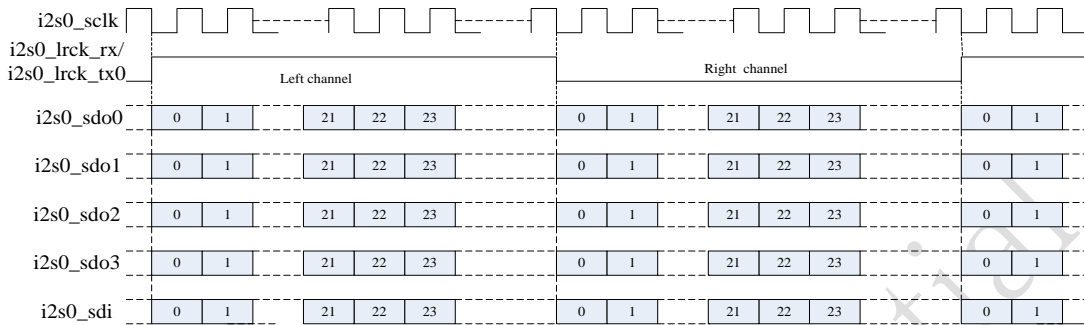

Fig. 16-5 I2S left justified mode timing format

16.3.3 i2s right justified mode

This is the waveform of I2S right justified mode. For LRCK (i2s_lrck_rx / i2s_lrck_tx0) signal, it goes high to indicate left channel and low to right channel. For SD (i2s_sdo0, i2s_sdo1, i2s_sdo2, i2s_sdo3, i2s_sdi) signal, it transfers MSB or LSB first; but different from I2S normal or left justified mode, its data is aligned to last bit at the edge of the LRCK signal. The range of SD signal width is from 16 to 32bits.

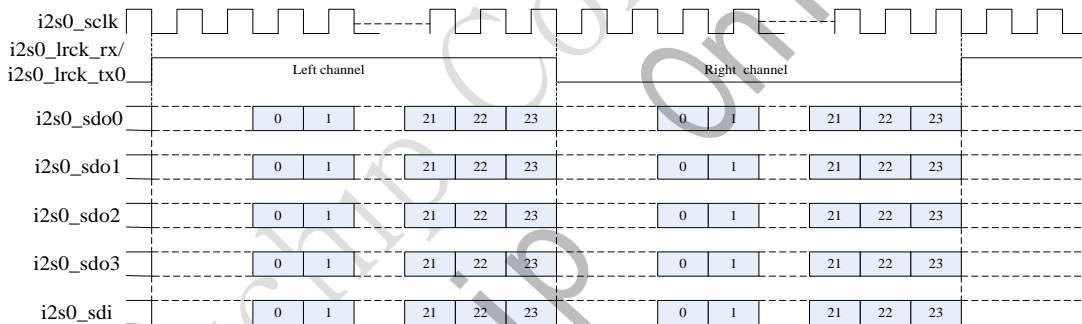

Fig. 16-6 I2S right justified mode timing format

16.3.4 PCM early mode

This is the waveform of PCM early mode. For LRCK (i2s_lrck_rx / i2s_lrck_tx0) signal, it goes high to indicate the start of a group of audio channels. For SD (i2s_sdo0, i2s_sdi) signal, it transfers MSB or LSB first and sends the first bit at the same time when LRCK goes high. The range of SD signal width is from 16 to 32bits.

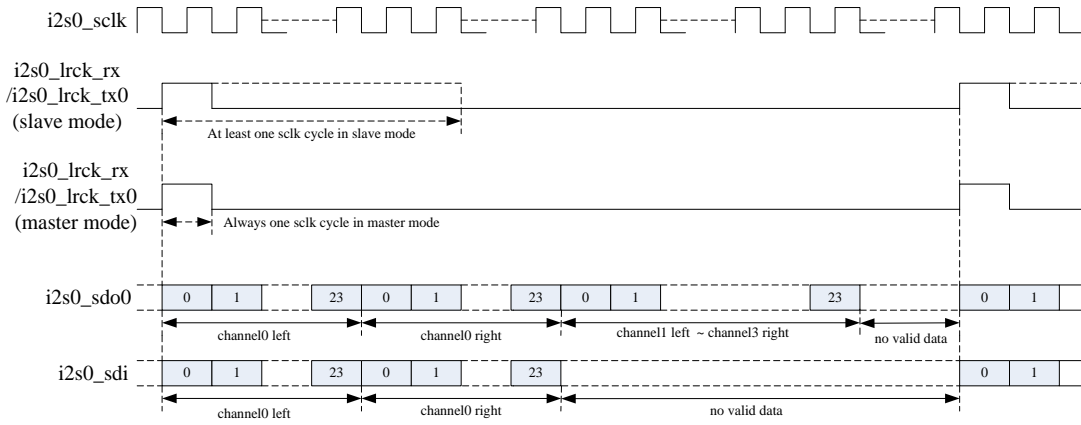

Fig. 16-7 PCM early modetiming format

16.3.5 PCM late1 mode

This is the waveform of PCM early mode. For LRCK (i2s_lrck_rx / i2s_lrck_tx0) signal, it goes high to indicate the start of a group of audio channels. For SD (i2s_sdo0, i2s_sdi) signal, it transfers MSB or LSB first and sends the first bit one SCLK clock cycle after LRCK goes high. The range of SD signal width is from 16 to 32bits.

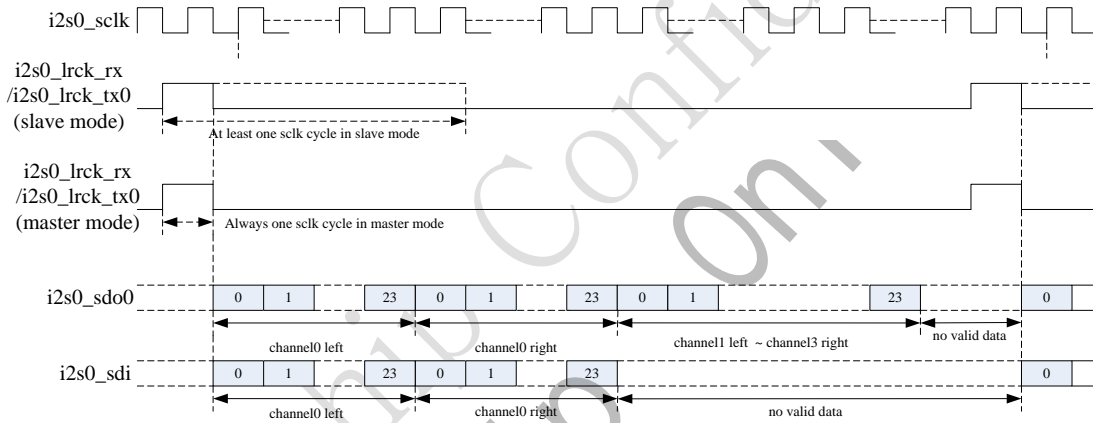

Fig. 16-8 PCM late1 modetiming format

16.3.6 PCM late2 mode

This is the waveform of PCM early mode. For LRCK (i2s_lrck_rx / i2s_lrck_tx0) signal, it goes high to indicate the start of a group of audio channels. For SD (i2s_sdo0, i2s_sdi) signal, it transfers MSB or LSB first and sends the first bit two SCLK clock cycles after LRCK goes high. The range of SD signal width is from 16 to 32bits.

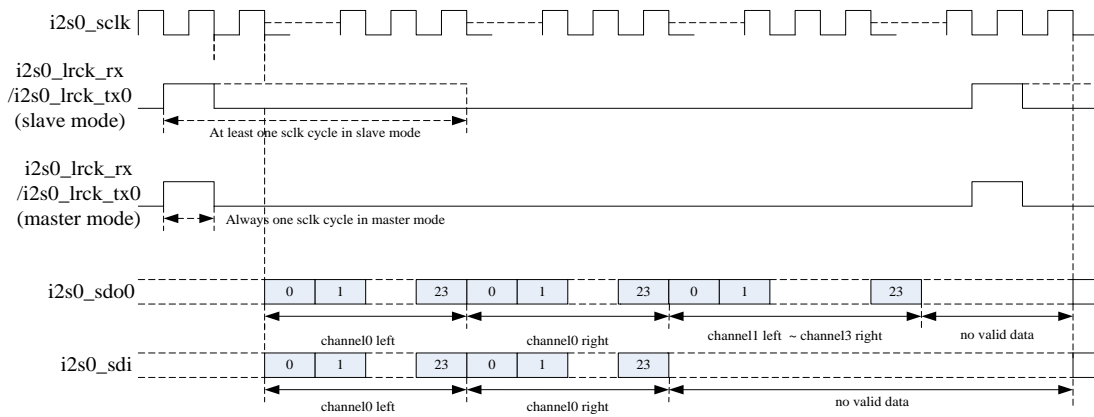

Fig. 16-9 PCM late2 modetiming format

16.3.7 PCM late3 mode

This is the waveform of PCM early mode. For LRCK (i2s_lrck_rx / i2s_lrck_tx0) signal, it goes high to indicate the start of a group of audio channels. For SD (i2s_sdo0, i2s_sdi) signal, it transfers MSB or LSB first and sends the first bit three SCLK clock cycles after LRCK goes high. The range of SD signal width is from 16 to 32bits.

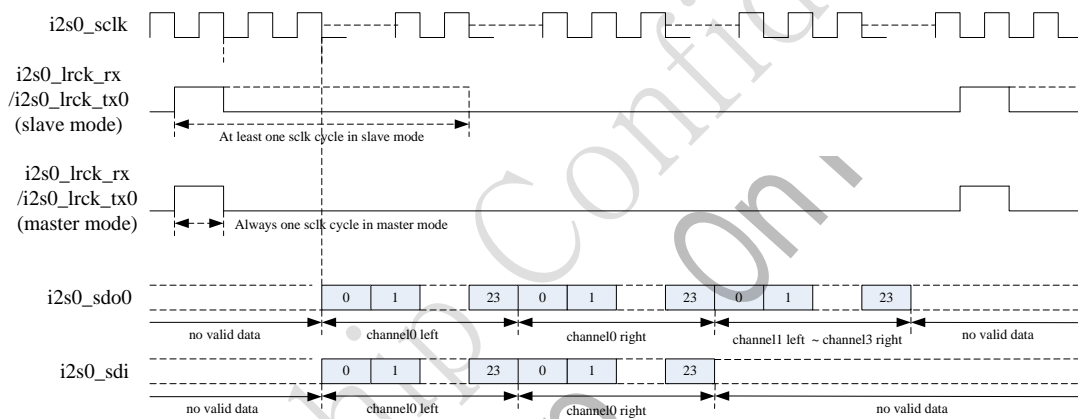

Fig. 16-10 PCM late3 modetiming format

16.4 Register Description

This section describes the control/status registers of the design.

16.4.1 Registers Summary

Name	Offset	Size	Reset Value	Description
I2S_TXCR	0x0000	W	0x0000000f	transmit operation control register
I2S_RXCR	0x0004	W	0x0000000f	receive operation control register
I2S_CKR	0x0008	W	0x00071f1f	clock generation register
I2S_FIFOLR	0x000c	W	0x00000000	FIFO level register
I2S_DMACR	0x0010	W	0x001f0000	DMA control register
I2S_INTCR	0x0014	W	0x01f00000	interrupt control register
I2S_INTSR	0x0018	W	0x00000000	interrupt status register
I2S_XFER	0x001c	W	0x00000000	Transfer Start Register
I2S_CLR	0x0020	W	0x00000000	SCLK domain logic clear Register
I2S_TXDR	0x0024	W	0x00000000	Transimt FIFO Data Register

Name	Offset	Size	Reset Value	Description
I2S_RXDR	0x0028	W	0x00000000	Receive FIFO Data Register

Notes: **Size: B**- Byte (8 bits) access, **HW**- Half WORD (16 bits) access, **W**-WORD (32 bits) access

16.4.2 Detail Register Description

I2S_TXCR

Address: Operational Base + offset (0x0000)
transmit operation control register

Bit	Attr	Reset Value	Description
31:23	RO	0x0	reserved
22:17	RW	0x00	RCNT right justified counter (Can be written only when XFER[0] bit is 0.) Only valid in I2S Right justified format and slave tx mode is selected. Start to transmit data RCNT sclk cycles after left channel valid.
16:15	RW	0x0	CSR Channel select register (Can be written only when XFER[0] bit is 0.) 0:channel 0 enable 1:channel 0 & channel 1 enable 2:channel 0 & channel 1 & channel 2 enable 3:channel 0 & channel 1 & channel 2 & channel 3 enable
14	RW	0x0	HWT Halfword word transform (Can be written only when XFER[0] bit is 0.) Only valid when VDW select 16bit data. 0:32 bit data valid from AHB/APB bus. Low 16 bit for left channel and high 16 bit for right channel. 1:low 16bit data valid from AHB/APB bus, high 16 bit data invalid.
13	RO	0x0	reserved
12	RW	0x0	SJM Store justified mode (Can be written only when XFER[0] bit is 0.) 16bit~31bit DATA stored in 32 bits width fifo. If VDW select 16bit data, this bit is valid only when HWT select 0. Because if HWT is 1, every fifo unit contain two 16bit data and 32 bit space is full, it is impossible to choose justified mode. 0:right justified 1:left justified

Bit	Attr	Reset Value	Description
11	RW	0x0	FBM First Bit Mode (Can be written only when XFER[0] bit is 0.) 0:MSB 1:LSB
10:9	RW	0x0	IBM I2S bus mode (Can be written only when XFER[0] bit is 0.) 0:I2S normal 1:I2S Left justified 2:I2S Right justified 3:reserved
8:7	RW	0x0	PBM PCM bus mode (Can be written only when XFER[0] bit is 0.) 0:PCM no delay mode 1:PCM delay 1 mode 2:PCM delay 2 mode 3:PCM delay 3 mode
6	RO	0x0	reserved
5	RW	0x0	TFS Transfer format select (Can be written only when XFER[0] bit is 0.) 0: I2S format 1: PCM format
4:0	RW	0x0f	VDW Valid Data width (Can be written only when XFER[0] bit is 0.) 0~14:reserved 15:16bit 16:17bit 17:18bit 18:19bit 28:29bit 29:30bit 30:31bit 31:32bit

I2S_RXCR

Address: Operational Base + offset (0x0004)

receive operation control register

Bit	Attr	Reset Value	Description
31:15	RO	0x0	reserved

Bit	Attr	Reset Value	Description
14	RW	0x0	HWT Halfword word transform (Can be written only when XFER[1] bit is 0.) Only valid when VDW select 16bit data. 0:32 bit data valid to AHB/APB bus. Low 16 bit for left channel and high 16 bit for right channel. 1:low 16bit data valid to AHB/APB bus, high 16 bit data invalid.
13	RO	0x0	reserved
12	RW	0x0	SJM Store justified mode (Can be written only when XFER[1] bit is 0.) 16bit~31bit DATA stored in 32 bits width fifo. If VDW select 16bit data, this bit is valid only when HWT select 0.Because if HWT is 1, every fifo unit contain two 16bit data and 32 bit space is full, it is impossible to choose justified mode. 0:right justified 1:left justified
11	RW	0x0	FBM First Bit Mode (Can be written only when XFER[1] bit is 0.) 0:MSB 1:LSB
10:9	RW	0x0	IBM I2S bus mode (Can be written only when XFER[1] bit is 0.) 0:I2S normal 1:I2S Left justified 2:I2S Right justified 3:reserved
8:7	RW	0x0	PBM PCM bus mode (Can be written only when XFER[1] bit is 0.) 0:PCM no delay mode 1:PCM delay 1 mode 2:PCM delay 2 mode 3:PCM delay 3 mode
6	RO	0x0	reserved
5	RW	0x0	TFS Transfer format select (Can be written only when XFER[1] bit is 0.) 0:i2s 1:pcm

Bit	Attr	Reset Value	Description
4:0	RW	0x0f	VDW Valid Data width (Can be written only when XFER[1] bit is 0.) 0~14:reserved 15:16bit 16:17bit 17:18bit 18:19bit 28:29bit 29:30bit 30:31bit 31:32bit

I2S_CKR

Address: Operational Base + offset (0x0008)

clock generation register

Bit	Attr	Reset Value	Description
31:28	RO	0x0	reserved
27	RW	0x0	MSS Master/slave mode select (Can be written only when XFER[1] or XFER[0] bit is 0.) 0:master mode(sclk output) 1:slave mode(sclk input)
26	RW	0x0	CKP Sclk polarity (Can be written only when XFER[1] or XFER[0] bit is 0.) 0: sample data at posedge sclk and drive data at negedge sclk 1: sample data at negedge sclk and drive data at posedge sclk

Bit	Attr	Reset Value	Description
25	RW	0x0	<p>RLP Receive Irck polarity (Can be written only when XFER[1] or XFER[0] bit is 0.) 0:normal polartiy (I2S normal: low for left channel, high for right channel I2S left/right just: high for left channel, low for right channel PCM start signal:high valid) 1:oppsite polarity (I2S normal: high for left channel, low for right channel I2S left/right just: low for left channel, high for right channel PCM start signal:low valid)</p>
24	RW	0x0	<p>TLP Transmit Irck polarity (Can be written only when XFER[1] or XFER[0] bit is 0.) 0:normal polartiy (I2S normal: low for left channel, high for right channel I2S left/right just: high for left channel, low for right channel PCM start signal:high valid) 1:oppsite polarity (I2S normal: high for left channel, low for right channel I2S left/right just: low for left channel, high for right channel PCM start signal:low valid)</p>

Bit	Attr	Reset Value	Description
23:16	RW	0x07	<p>MDIV mclk divider (Can be written only when XFER[1] or XFER[0] bit is 0.) Serial Clock Divider = Fmclk / Ftxsclk-1.(mclk frequency / txsclk frequency-1)</p> <p>0 :Fmclk=Ftxsclk; 1 :Fmclk=2*Ftxsclk; 2,3 :Fmclk=4*Ftxsclk; 4,5 :Fmclk=6*Ftxsclk; 60,61:Fmclk=62*Ftxsclk; 62,63:Fmclk=64*Ftxsclk; 252,253:Fmclk=254*Ftxsclk; 254,255:Fmclk=256*Ftxsclk;</p>
15:8	RW	0x1f	<p>RSD Receive sclk divider (Can be written only when XFER[1] or XFER[0] bit is 0.) Receive sclk divider= Fsclk/Frxlrck</p> <p>0~30:reserved 31: 32fs 32: 33fs 33: 34fs 34: 35fs 253: 254fs 254: 255fs 255: 256fs</p>
7:0	RW	0x1f	<p>TSD Transmit sclk divider (Can be written only when XFER[1] or XFER[0] bit is 0.) Transmit sclk divider=Ftxsclk/Ftxlrck</p> <p>0~30:reserved 31: 32fs 32: 33fs 33: 34fs 34: 35fs 253: 254fs 254: 255fs 255: 256fs</p>

I2S_FIFOLR

Address: Operational Base + offset (0x000c)

FIFO level register

Bit	Attr	Reset Value	Description
31:30	RO	0x0	reserved
29:24	RO	0x00	RFL Receive FIFO Level Contains the number of valid data entries in the receive FIFO.
23:18	RO	0x00	TFL3 Transmit FIFO3 Level Contains the number of valid data entries in the transmit FIFO3.
17:12	RO	0x00	TFL2 Transmit FIFO2 Level Contains the number of valid data entries in the transmit FIFO2.
11:6	RO	0x00	TFL1 Transmit FIFO1 Level Contains the number of valid data entries in the transmit FIFO1.
5:0	RO	0x00	TFL0 Transmit FIFO0 Level Contains the number of valid data entries in the transmit FIFO0.

I2S_DMACR

Address: Operational Base + offset (0x0010)

DMA control register

Bit	Attr	Reset Value	Description
31:25	RO	0x0	reserved
24	RW	0x0	RDE Receive DMA Enable 0 : Receive DMA disabled 1 : Receive DMA enabled
23:21	RO	0x0	reserved
20:16	RW	0x1f	RDL Receive Data Level This bit field controls the level at which a DMA request is made by the receive logic. The watermark level = DMARDL+1; that is, dma_rx_req is generated when the number of valid data entries in the receive FIFO is equal to or above this field value + 1.
15:9	RO	0x0	reserved

Bit	Attr	Reset Value	Description
8	RW	0x0	TDE Transmit DMA Enable 0 : Transmit DMA disabled 1 : Transmit DMA enabled
7:5	RO	0x0	reserved
4:0	RW	0x00	TDL Transmit Data Level This bit field controls the level at which a DMA request is made by the transmit logic. It is equal to the watermark level; that is, the dma_tx_req signal is generated when the number of valid data entries in the TXFIFO(TXFIFO0 if CSR=00;TXFIFO1 if CSR=01, TXFIFO2 if CSR=10, TXFIFO3 if CSR=11)is equal to or below this field value.

I2S_INTCR

Address: Operational Base + offset (0x0014)

interrupt control register

Bit	Attr	Reset Value	Description
31:25	RO	0x0	reserved
24:20	RW	0x1f	RFT Receive FIFO Threshold When the number of receive FIFO entries is more than or equal to this threshold plus 1, the receive FIFO full interrupt is triggered.
19	RO	0x0	reserved
18	WO	0x0	RXOIC RX overrun interrupt clear Write 1 to clear RX overrun interrupt.
17	RW	0x0	RXOIE RX overrun interrupt enable 0:disable 1:enable
16	RW	0x0	RXFIE RX full interrupt enable 0:disable 1:enable
15:9	RO	0x0	reserved
8:4	RW	0x00	TFT Transmit FIFO Threshold When the number of transmit FIFO (TXFIFO0 if CSR=00; TXFIFO1 if CSR=01, TXFIFO2 if CSR=10, TXFIFO3 if CSR=11) entries is less than or equal to this threshold, the transmit FIFO empty interrupt is triggered.

Bit	Attr	Reset Value	Description
3	RO	0x0	reserved
2	WO	0x0	TXUIC TX underrun interrupt clear Write 1 to clear TX underrun interrupt.
1	RW	0x0	TXUIE TX underrun interrupt enable 0:disable 1:enable
0	RW	0x0	TXEIE TX empty interrupt enable 0:disable 1:enable

I2S_INTSR

Address: Operational Base + offset (0x0018)

interrupt status register

Bit	Attr	Reset Value	Description
31:18	RO	0x0	reserved
17	RO	0x0	RXOI RX overrun interrupt 0:inactive 1:active
16	RO	0x0	RXFI RX full interrupt 0:inactive 1:active
15:2	RO	0x0	reserved
1	RO	0x0	TXUI TX underrun interrupt 0:inactive 1:active
0	RO	0x0	TXEI TX empty interrupt 0:inactive 1:active

I2S_XFER

Address: Operational Base + offset (0x001c)

Transfer Start Register

Bit	Attr	Reset Value	Description
31:2	RO	0x0	reserved
1	RW	0x0	RXS RX Transfer start bit 0:stop RX transfer. 1:start RX transfer

Bit	Attr	Reset Value	Description
0	RW	0x0	TXS TX Transfer start bit 0:stop TX transfer. 1:start TX transfer

I2S_CLR

Address: Operational Base + offset (0x0020)

SCLK domain logic clear Register

Bit	Attr	Reset Value	Description
31:2	RO	0x0	reserved
1	RW	0x0	RXC RX logic clear This is a self cleared bit. Write 1 to clear all receive logic.
0	RW	0x0	TXC TX logic clear This is a self cleared bit. Write 1 to clear all transmit logic.

I2S_TXDR

Address: Operational Base + offset (0x0400~0x7FC)

Transimt FIFO Data Register

Bit	Attr	Reset Value	Description
31:0	WO	0x00000000	TXDR Transimt FIFO Data Register When it is written to, data are moved into the transmit FIFO.

I2S_RXDR

Address: Operational Base + offset (0x0800~0xBFC)

Receive FIFO Data Register

Bit	Attr	Reset Value	Description
31:0	RO	0x00000000	RXDR Receive FIFO Data Register When the register is read, data in the receive FIFO is accessed.

16.5 Interface description

Module Pin	Direction	Pad Name	IOMUX Setting
i2s_sdi	I	IO_I2Ssdi_AUDI Ogpio6a3	GRF_GPIO6A_IOMUX[6]=1
i2s_clk	O	IO_I2Sclk_AUDI Ogpio6b0	GRF_GPIO6B_IOMUX[0]=1
i2s_sclk	I/O	IO_I2Ssclk_AUDI IOgpio6a0	GRF_GPIO6A_IOMUX[0]=1

i2s_lrck_rx	I/O	IO_I2Slrckrx_A UDIOgpio6a1	GRF_GPIO6A_IOMUX[2]=1
i2s_lrck_tx	I/O	IO_I2Slrcktx_A UDIOgpio6a2	GRF_GPIO6A_IOMUX[4]=1
i2s_sdo0	O	IO_I2Ssdo0_AU DIOgpio6a4	GRF_GPIO6A_IOMUX[8]=1
i2s_sdo1	O	IO_I2Ssdo1_AU DIOgpio6a5	GRF_GPIO6A_IOMUX[10]=1
i2s_sdo2	O	IO_I2Ssdo2_AU DIOgpio6a6	GRF_GPIO6A_IOMUX[12]=1
i2s_sdo3	O	IO_I2Ssdo3_AU DIOgpio6a7	GRF_GPIO6A_IOMUX[14]=1

16.6 Application Notes

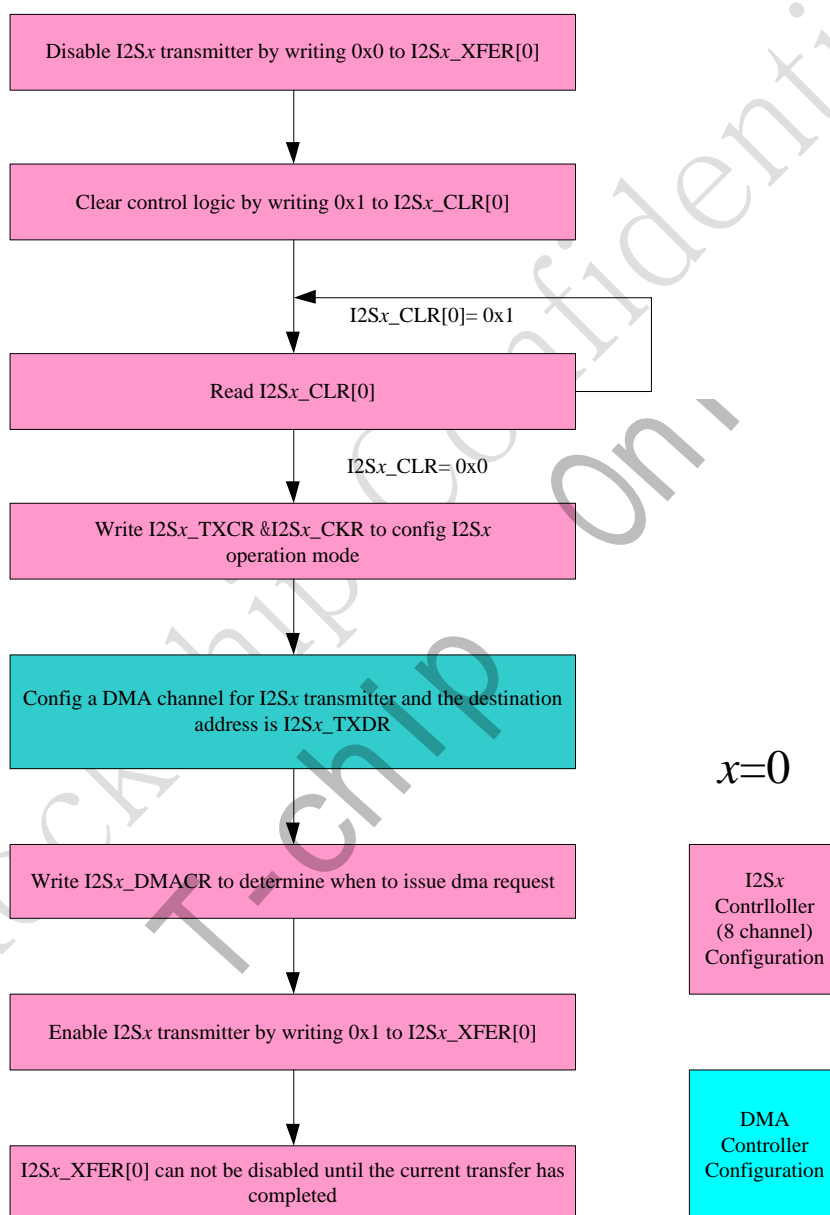

Fig. 16-11 I2S/PCM controller (8 channel) transmit operation flow chart

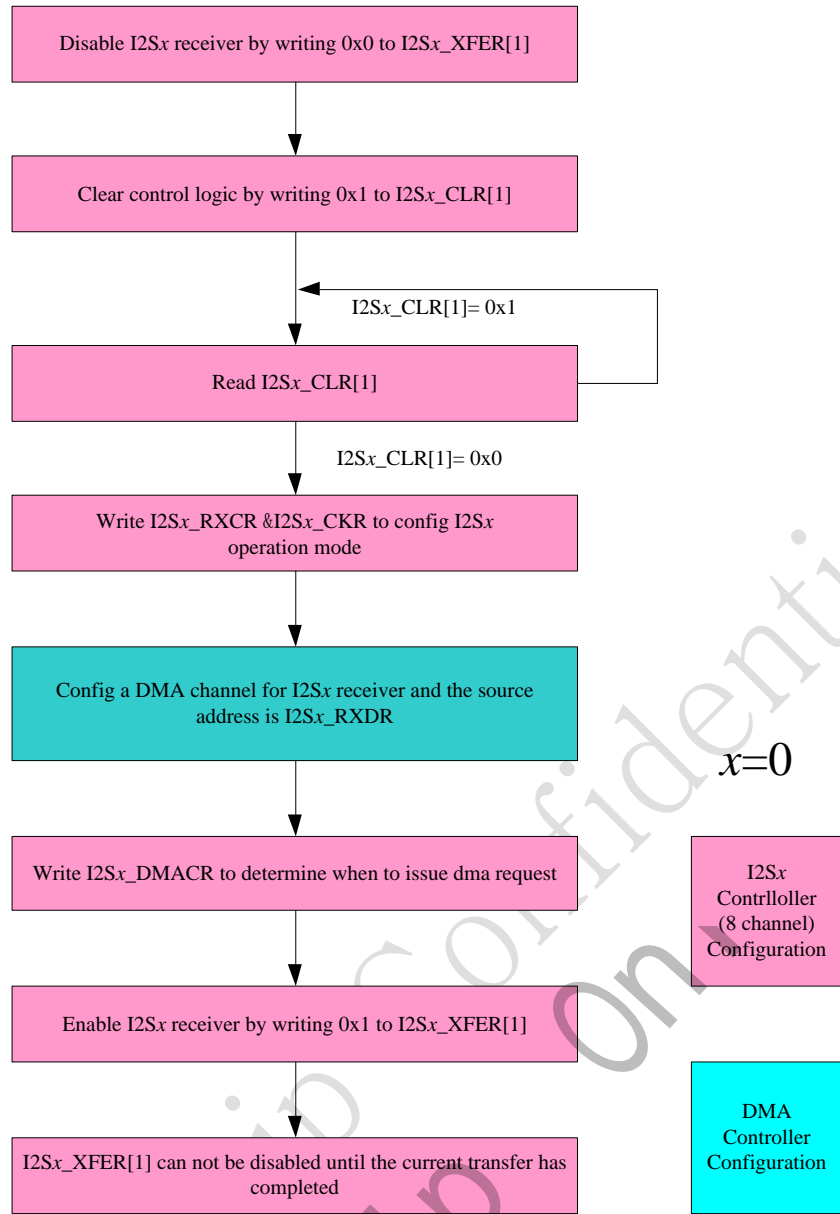

Fig. 16-12 I2S/PCM controller (8 channel) receive operation flow chart