







Content Indexing

01. Index
02. Block Diagram
03. Power Tree
04. System Power
05. RK3288 USB/HSIC Controller
06. USB HOST Port
07. RK3288 RAM Controller
08. RAM-DDR3-4X16bit
09. Nand FLASH/eMMC/TF Card
10. RK3288 GPIO/POWER
11. HDMI OUT
12. RK3288 LCD/MI2S Controller
13. ES8323
14. S/PDIF OUT
15. RK3288 Ethernet MAC Controller
16. 10/100/1000M-PHY
17. RK3288 SDIO0 Controller
18. AP6XXX-WIFI/BT
19. VGA
20. Camera Interface
21. DTV-(Reserve)

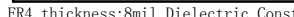
6 LAYERS PCB STACK

TOP (Signal1)  Cu, thickness: 0.7mil, Plating to 1oz
GND1  FR4, thickness: 3.8mil, Dielectric Constant: 4.3
POWER  FR4, thickness: 8mil, Dielectric Constant: 4.3
FR4, thickness: adjust thickness according to the thickness of board, Dielectric Constant: 4.3
Signal2  Cu, thickness: 1.5mil, 1oz
GND2  FR4, thickness: 8mil, Dielectric Constant: 4.3
 FR4, thickness: 3.8mil, Dielectric Constant: 4.3
BOTTOM (Signal3)  Cu, thickness: 0.7mil, Plating to 1oz

Firefly

Title: Index

File:

REV: 1.1

Create Date:

Page Num: 1

Modify Date: Wednesday, June 18, 2014

Page Total: 21

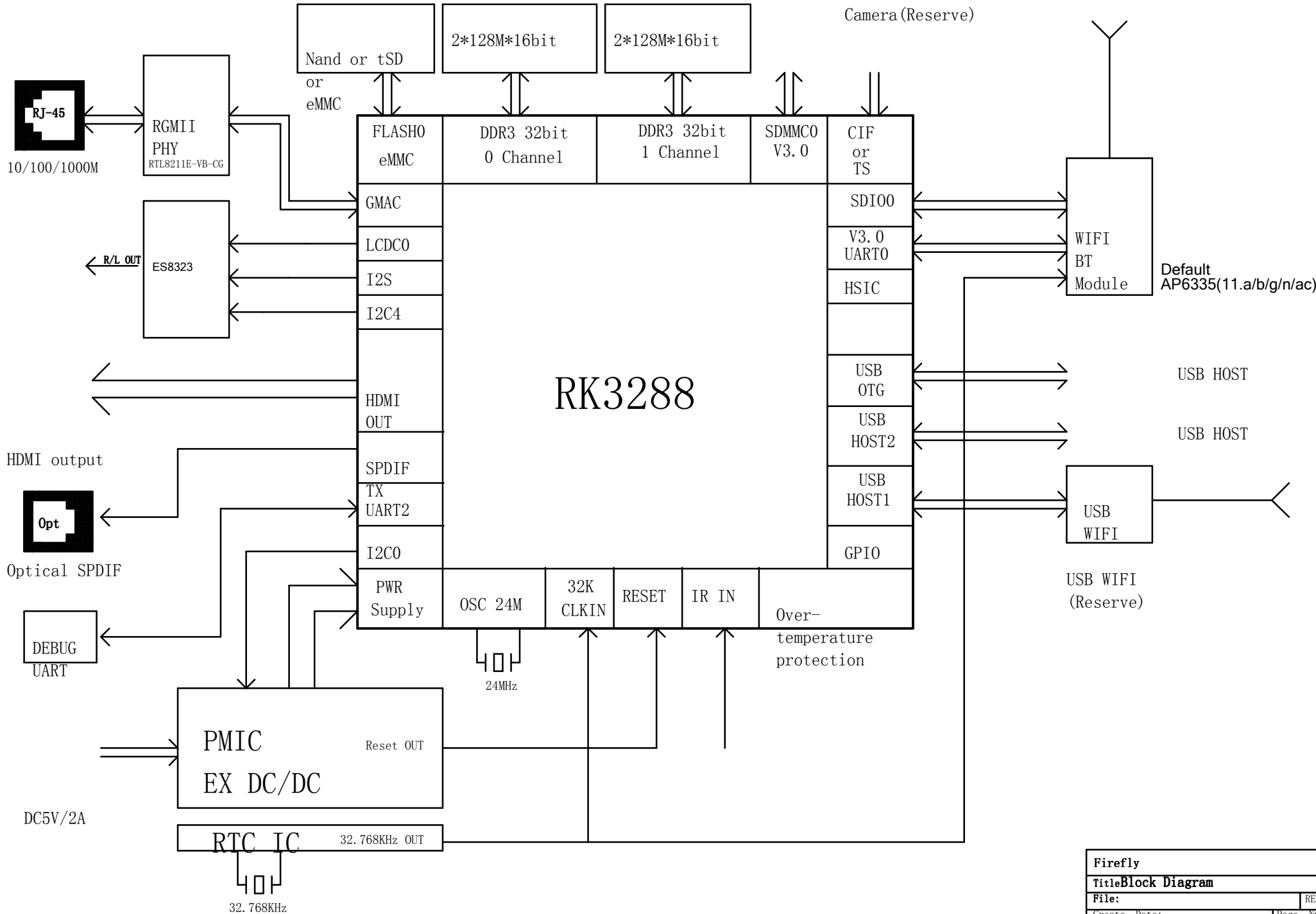

Firefly	
TitleBlock Diagram	
File:	REV:L.1
Create Date:	Page Num
Modify Date: Wednesday, June 18, 2014	Page Total

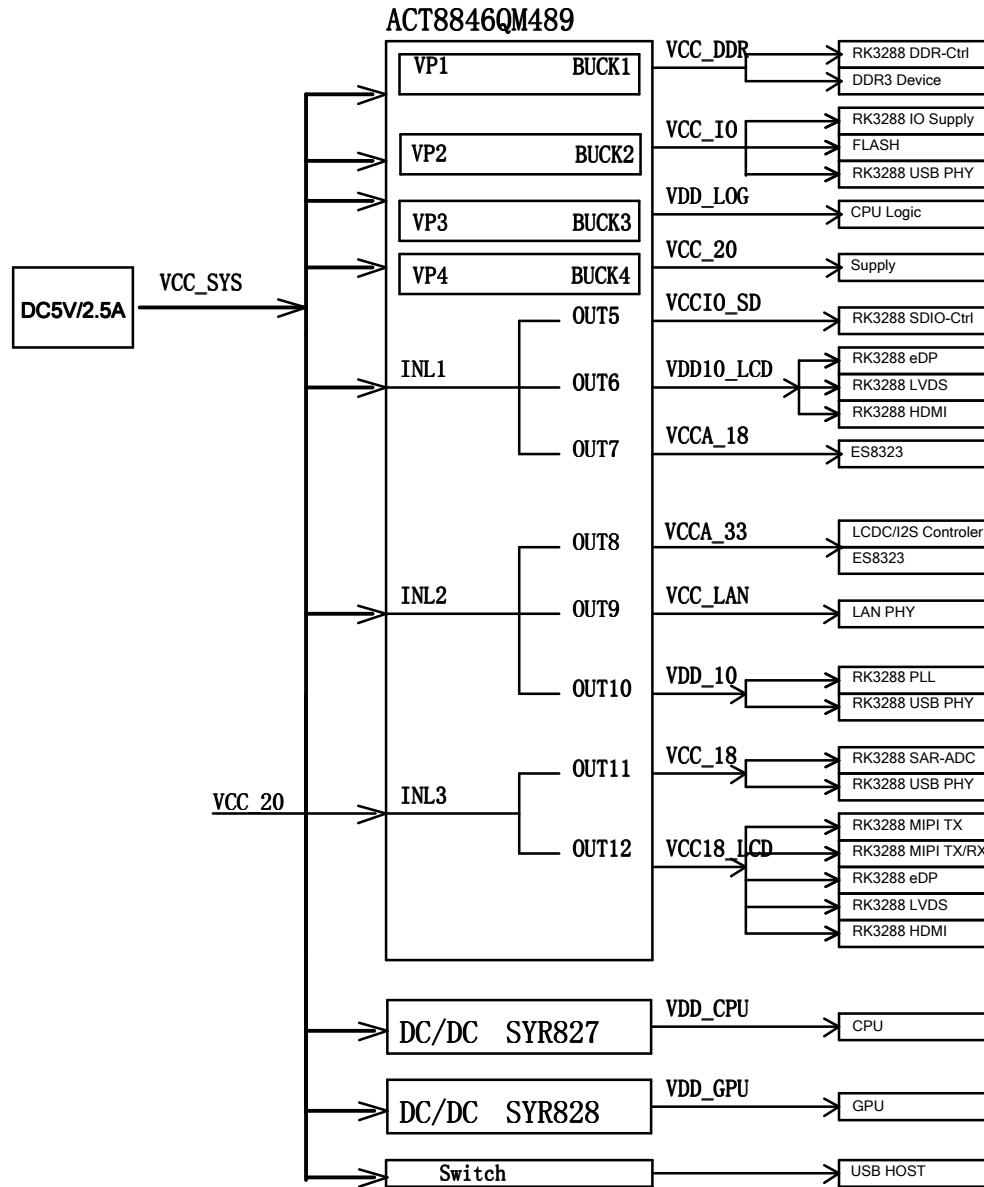

PowerName	PMIC Channel	timer(2mS)	Default	Working
VCC_20	DCDC4	Solt:0	voltage 2.0V	voltage 2.0V
VDD_10	OUT10	Solt:1	1.0V	1.0V
VCC_DDR	DCDC1	Solt:2	1.5V	1.5V(DDR3)
VDD_CPU	EX DCDC	Solt:2A	(FB=1.2V) 1.0V	DVFS
VDD_GPU	EX DCDC	Solt:2B	1.0V	DVFS
VDD_LOG	DCDC3	Solt:3	1.1V	DVFS
VCC_18	OUT11	Solt:4	1.8V	1.8V
VCC_LAN	OUT9	Solt:5	3.3V	3.3V
VCC_IO	DCDC2	Solt:6	3.3V	3.3V
VCCIO_SD	OUT5	Solt:6	3.3V	SD2.0:3.3V
VCCA_33	OUT8	OFF	OFF	SD3.0:1.8V 3.3V
VCCA_18	OUT7	OFF	OFF	1.8V
VDD10_LCD	OUT6	OFF	OFF	1.0V
VCC18_LCD	OUT12	OFF	OFF	1.8V

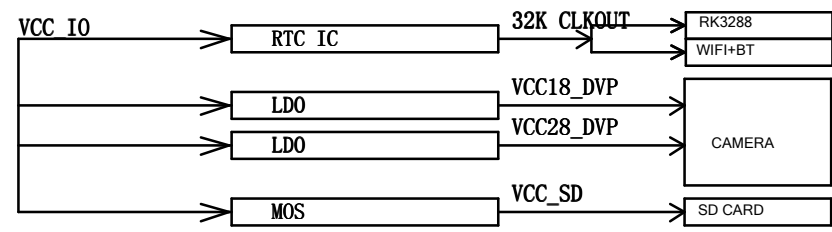

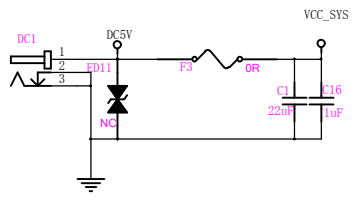

5V/2A

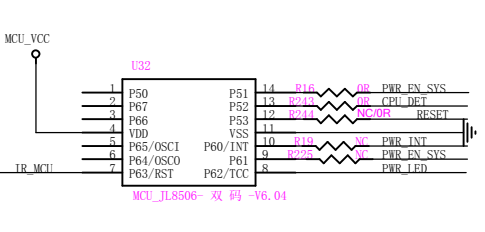
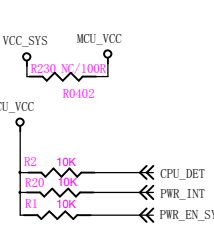
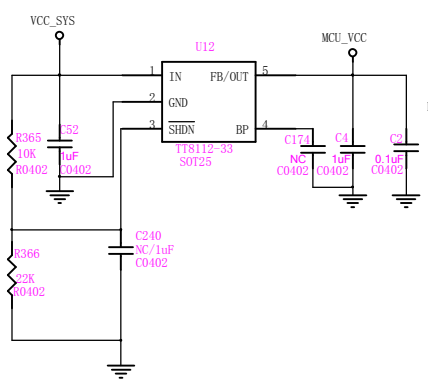

Working LED

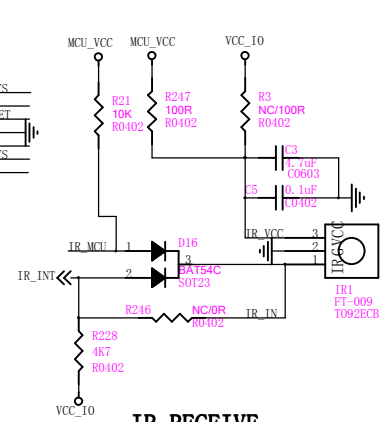

IR RECEIVE

SYSTEM POWER

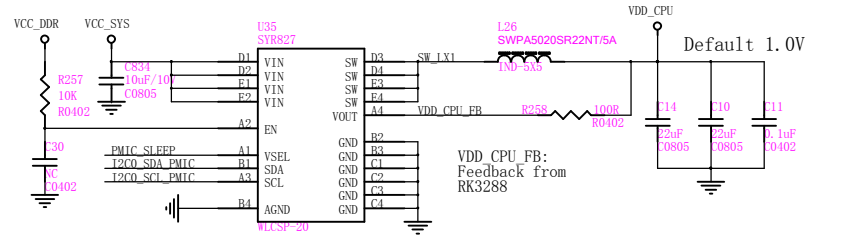
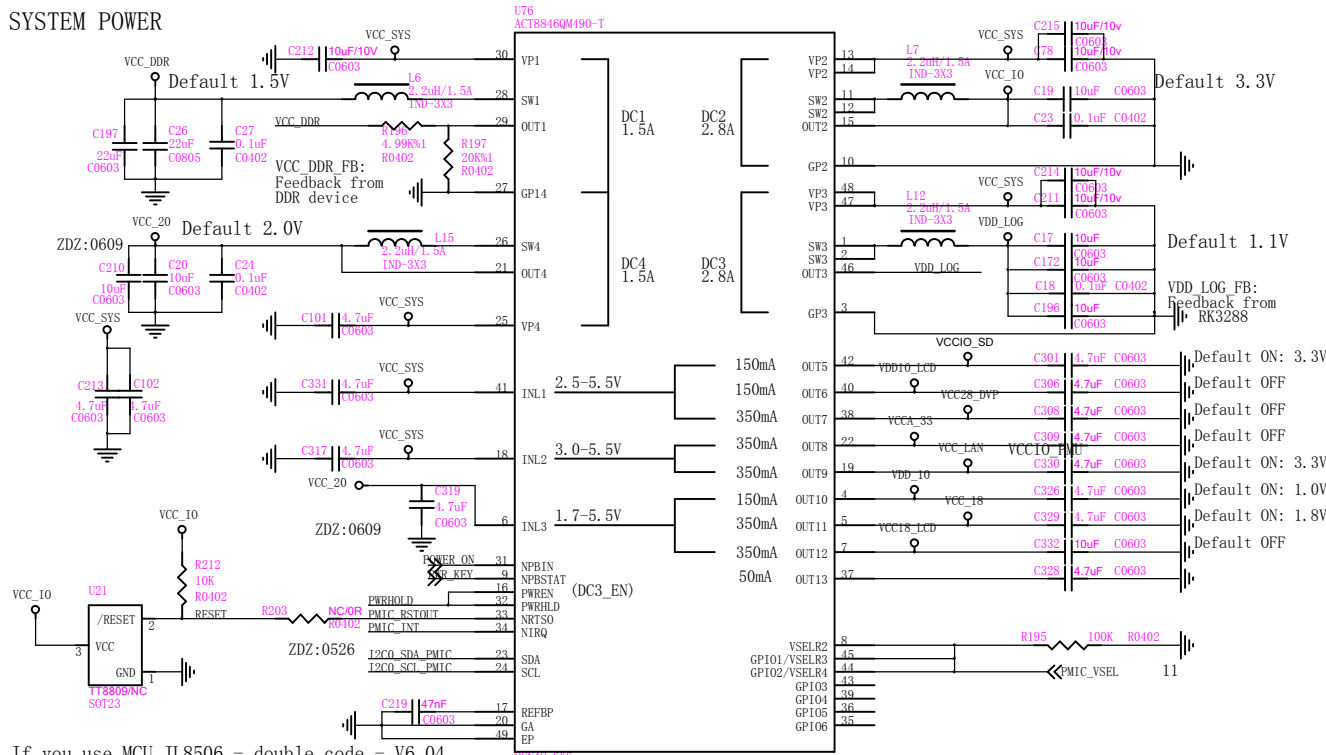

SYR827	I2C Address: 0x40h
SYR828	I2C Address: 0x41h

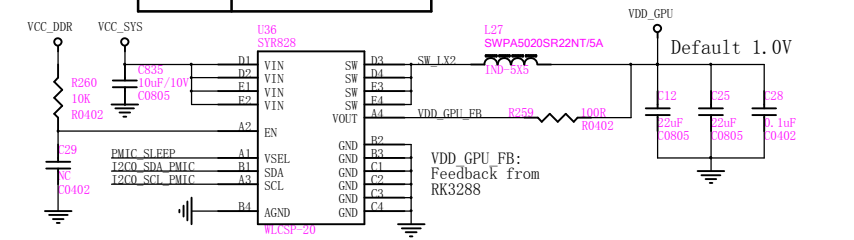

RTC IC

If you use MCU_JL8506 - double code - V6.04
Need to use external reset IC.
R203 don't stick.

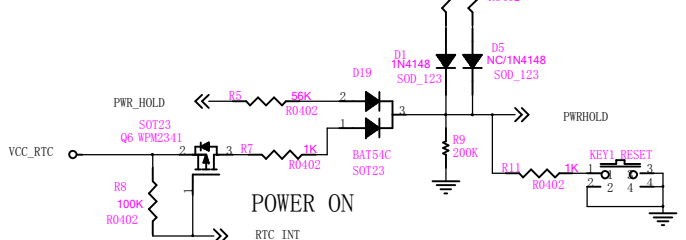
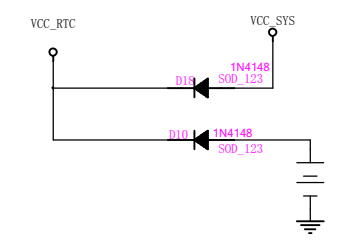
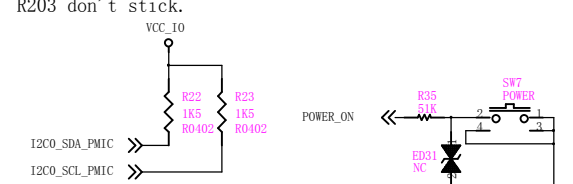

Firefly	
Title: System Power	REV: 1.1
File:	Page Num: 4
Create Date:	Page total: 21
Modify Date: Wednesday, June 18, 2014	

U1-E
MCU_RK3288

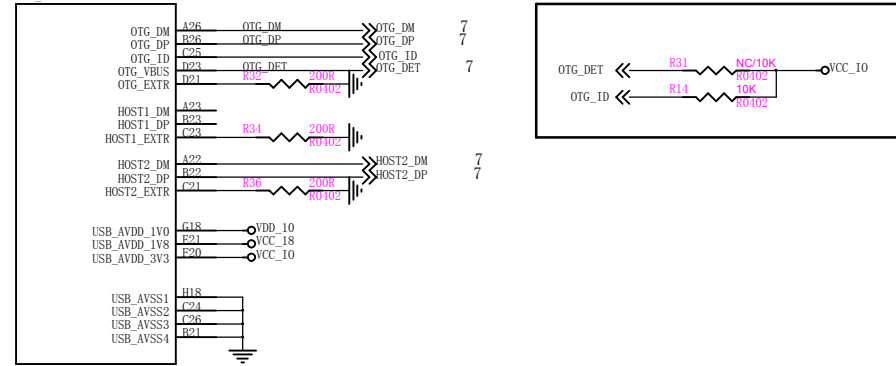

RK3288_E

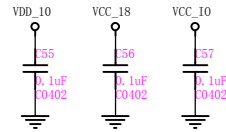

U1-U
MCU_RK3288

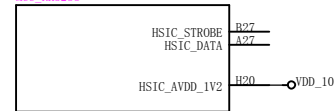

RK3288_U

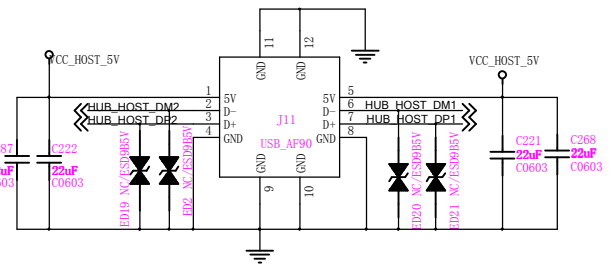
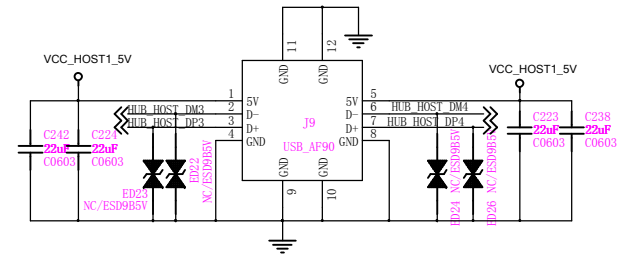
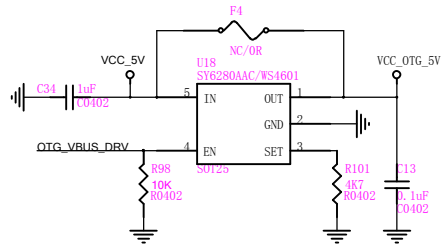
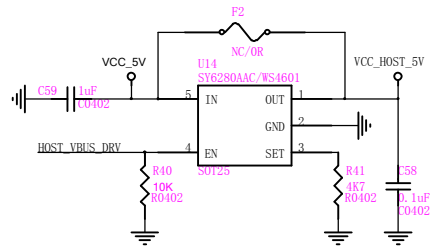
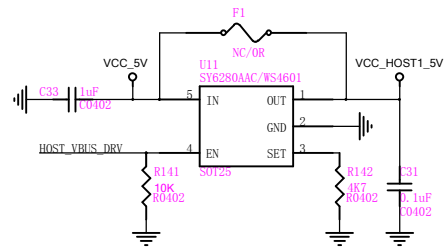
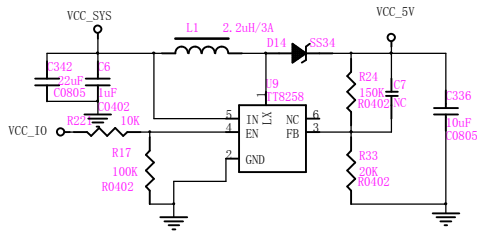

USB POWER

HOST

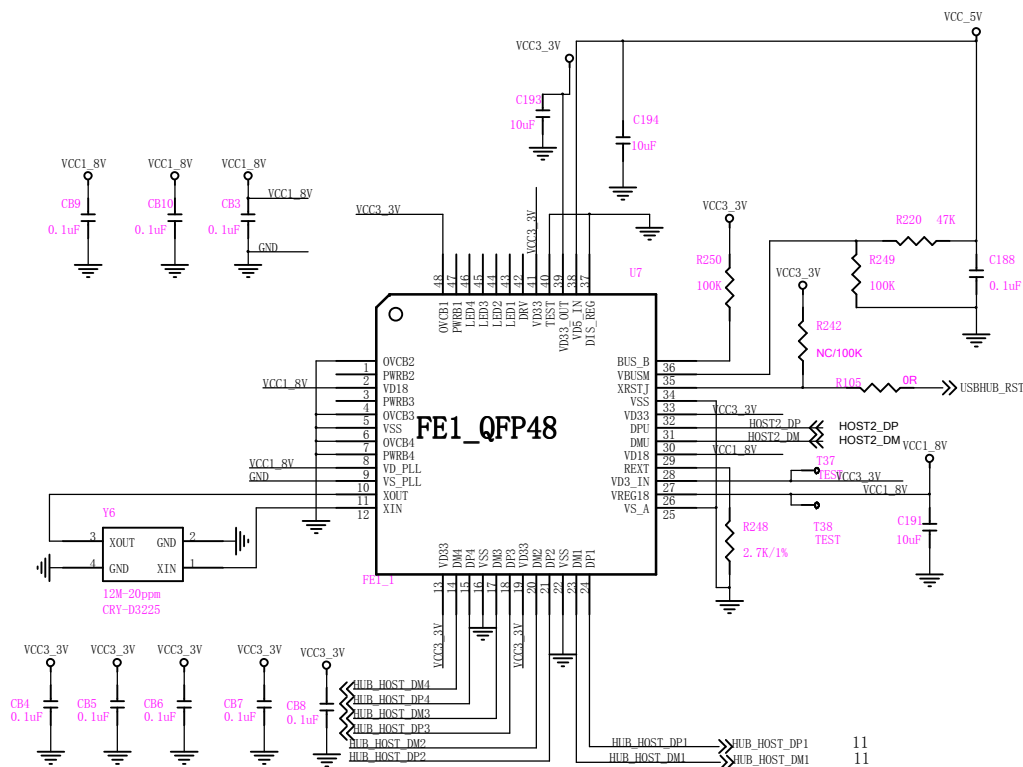

HUB CHIP

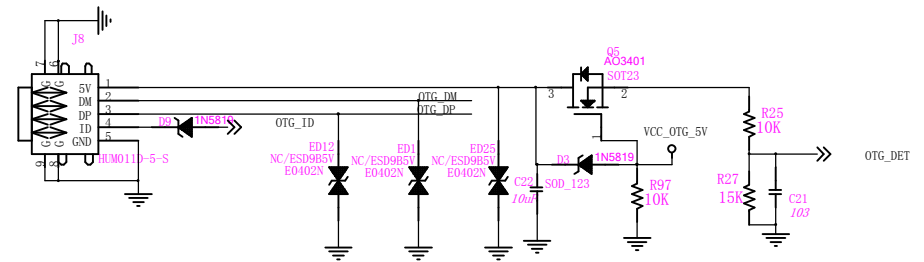

OTG

Firefly	
Title: USB HOST	REV: 1.1
File:	Page Num: 6
Create Date:	Page Total: 21
Modify Date: Wednesday, June 18, 2014	

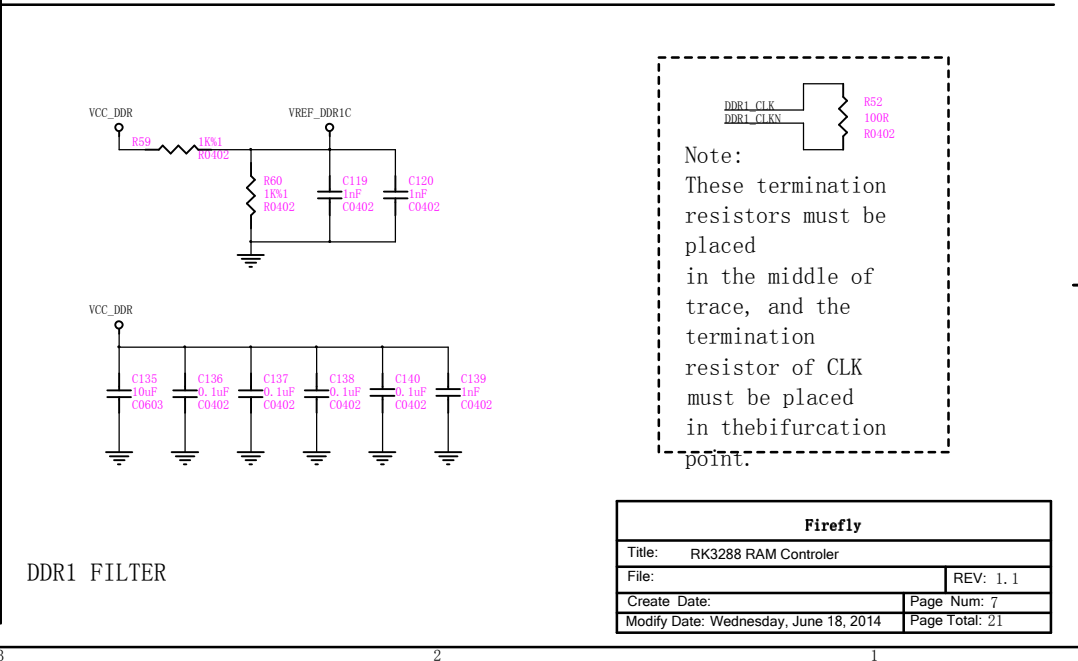
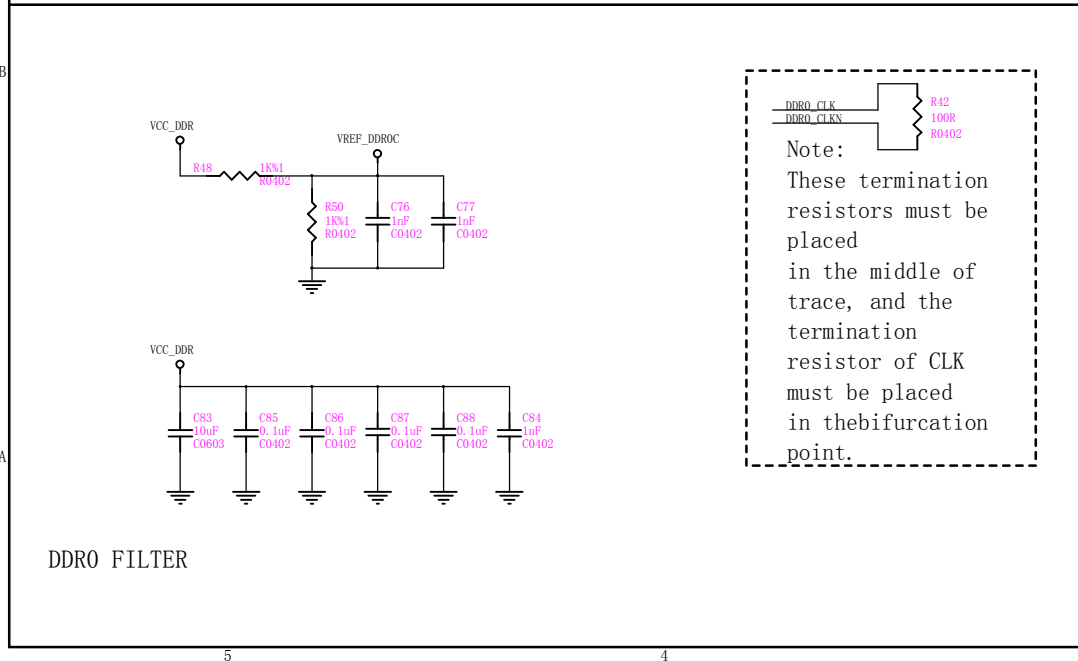
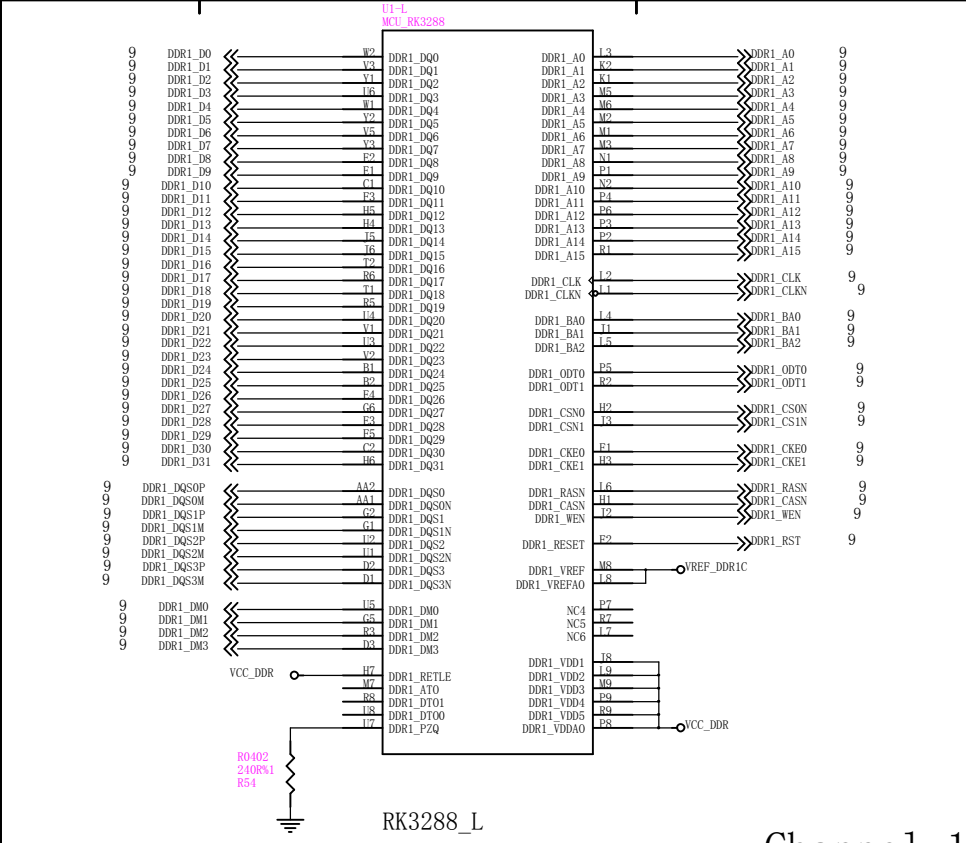
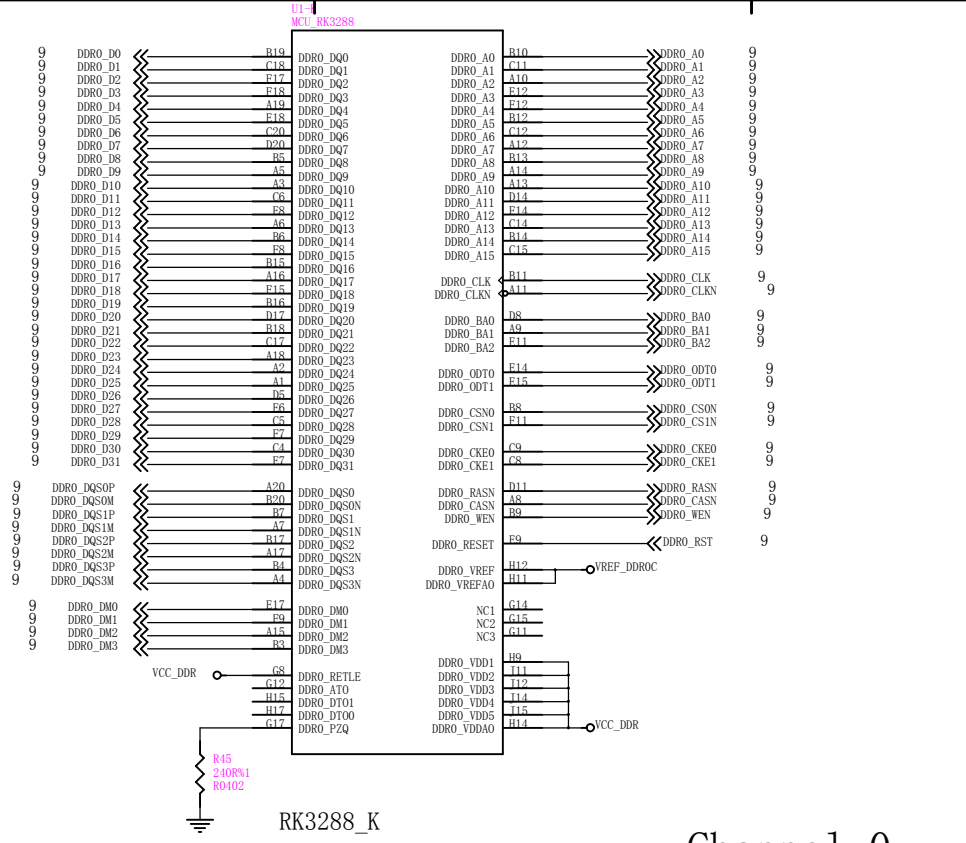

Firefly	
Title:	RK3288 RAM Controller
File:	REV: 1.1
Create Date:	Page Num: 7
Modify Date: Wednesday, June 18, 2014	Page Total: 21

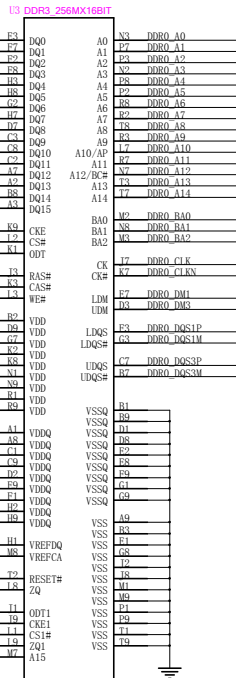
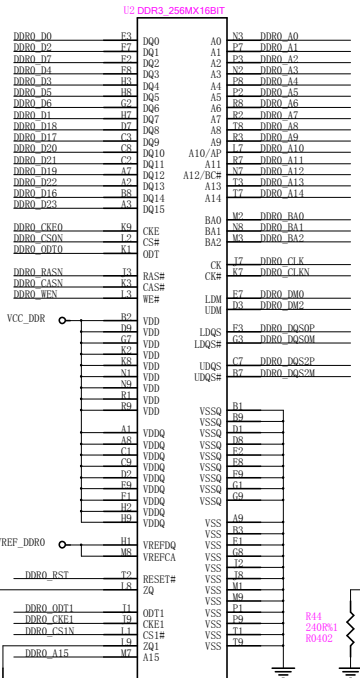

DDR3

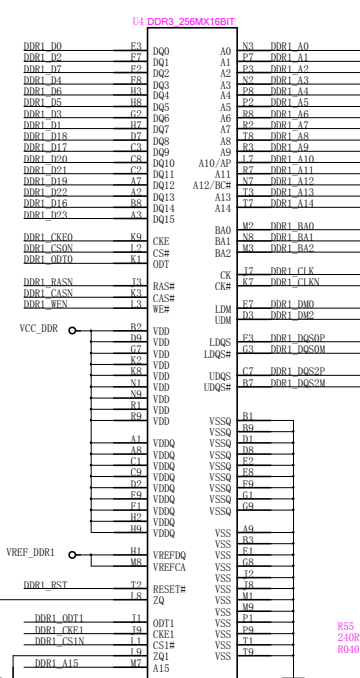

DDR3

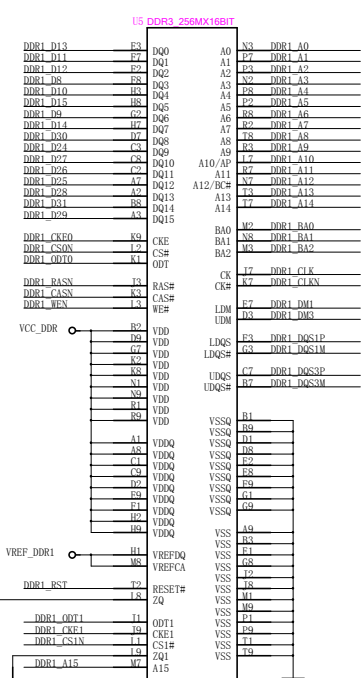

DDR3

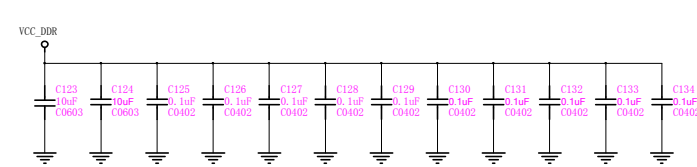
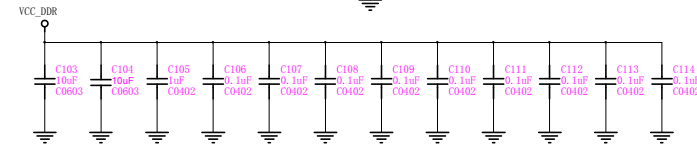
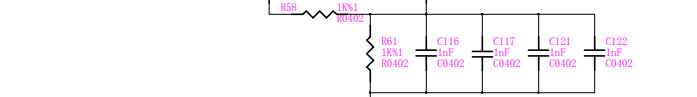

DDR1 FILTER

DDRO FILTER

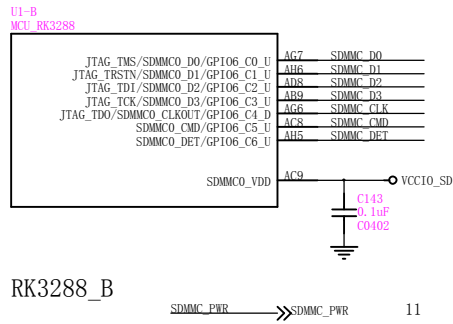

RK3288_B

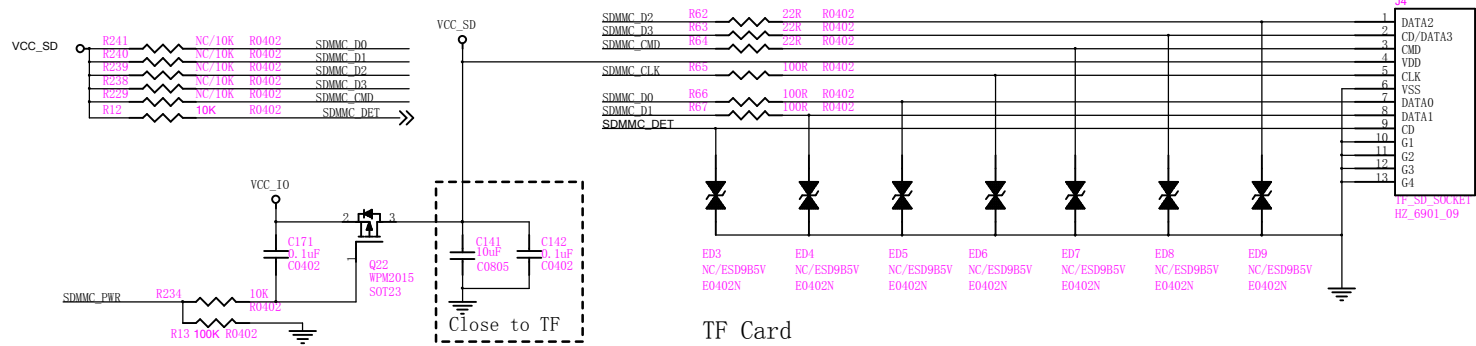

TF Card

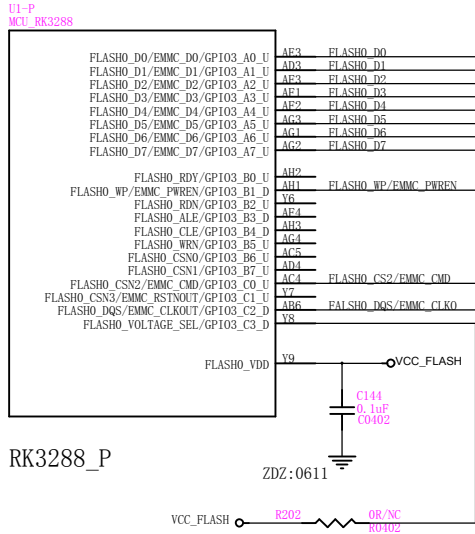

RK3288_P

Connect :1.8V
No Connect: 3.3V

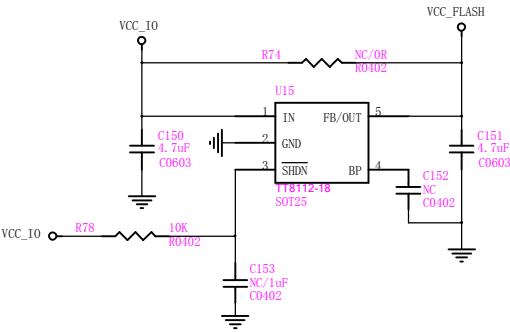

Flash Power

eMMC (default)

Note:

Reserve a PAD.

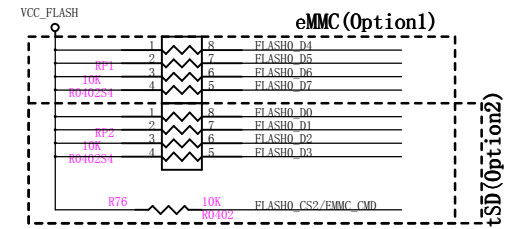
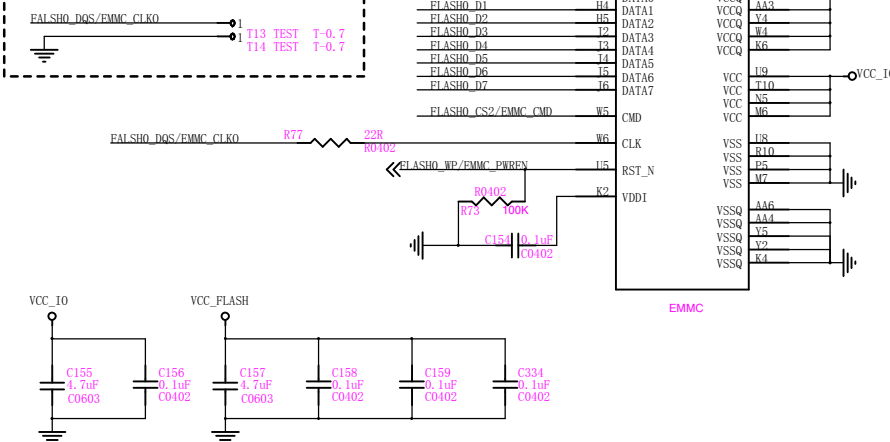

Pull-up select

Firefly	
Title:	Nand FLASH/eMMC/TF Card
File:	REV: 1.1
Create Date:	Page Num:9
Modify Date: Wednesday, June 18, 2014	Page Total: 21

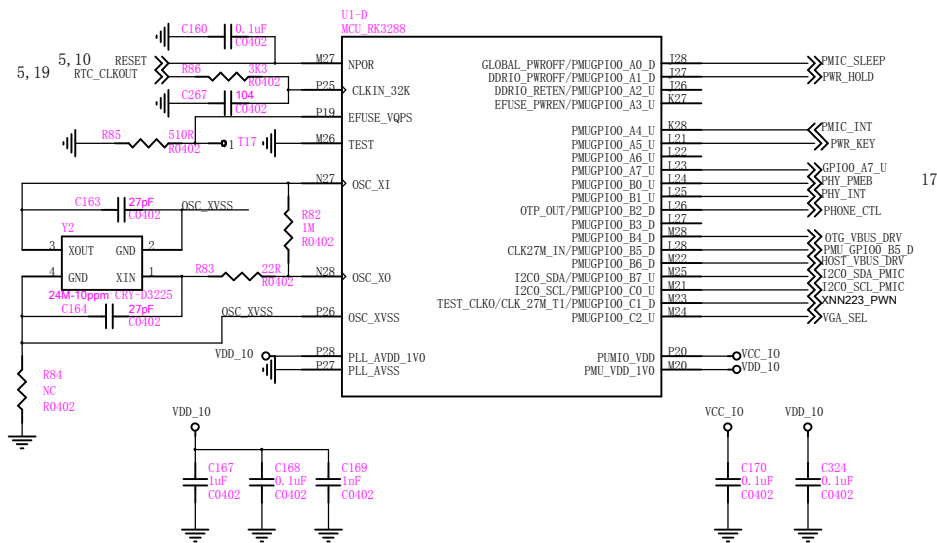

RK3288_D

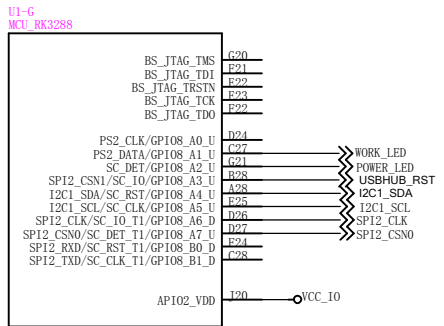

RK3288_G

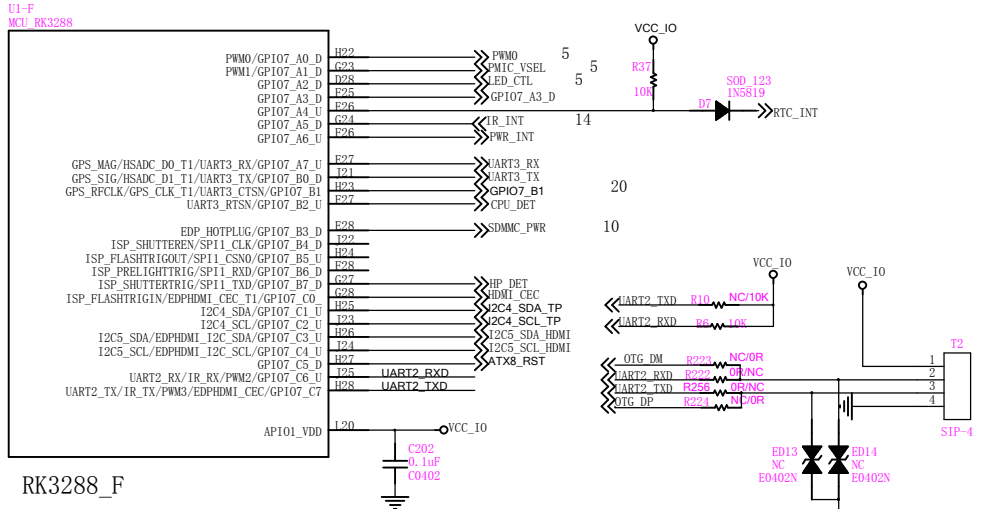

RK3288_F

For debug (Default)

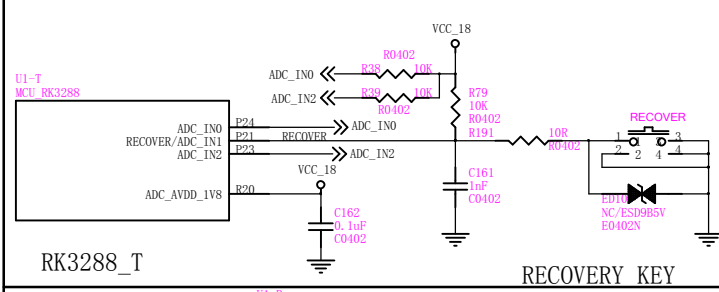

RK3288_T

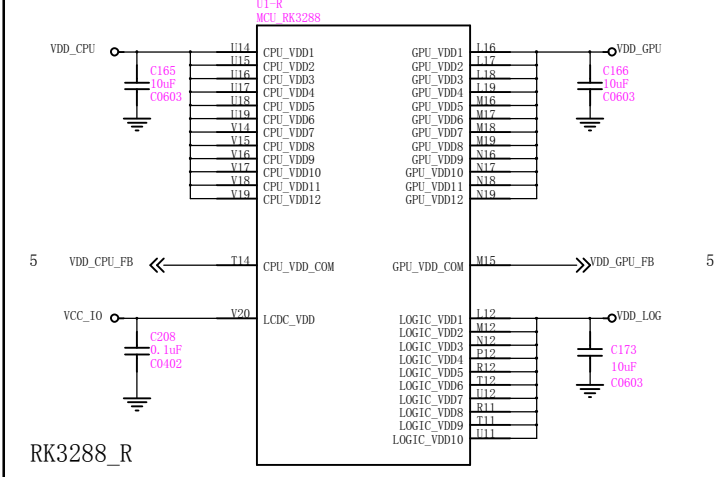

RK3288_R

RK3288 FILTER

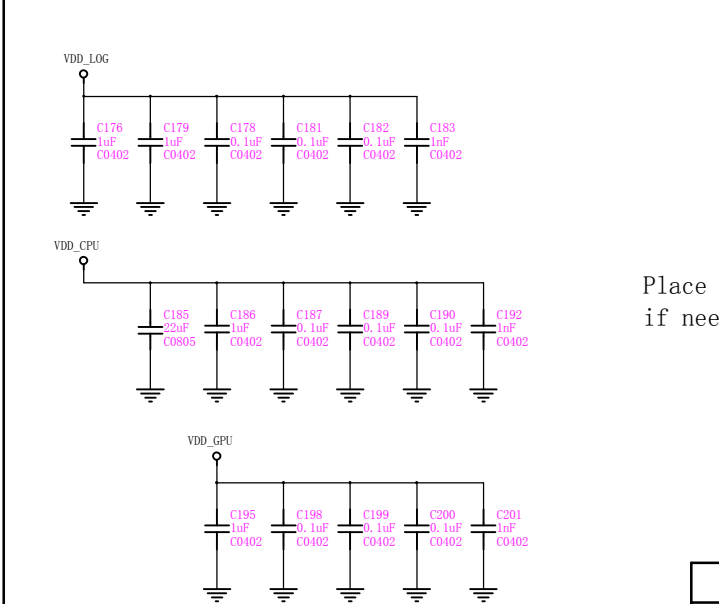

Place the Component if need to write eFUSE

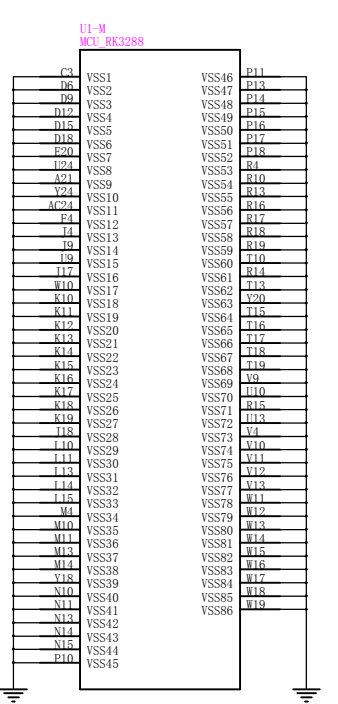

RK3288_M

Firefly	
Title: RK3288 GPIO/POWER	REV: 1.1
File:	
Create Date:	Page Num: 10
Modify Date: Wednesday, June 18, 2014	Page Total: 21

U1-0
MCU_RK3288

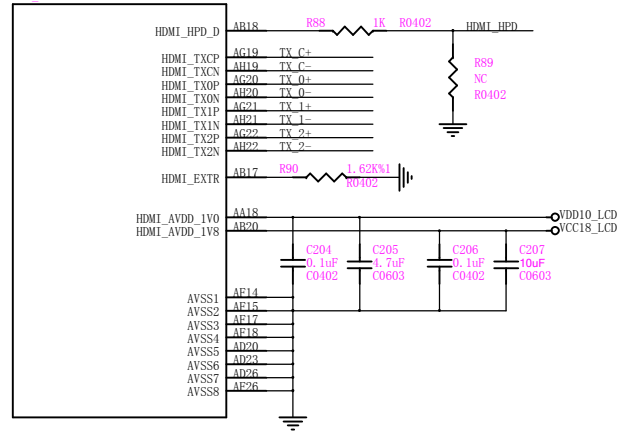

RK3288_0

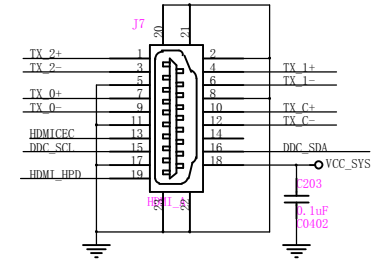
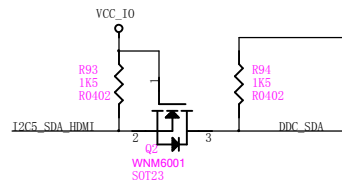
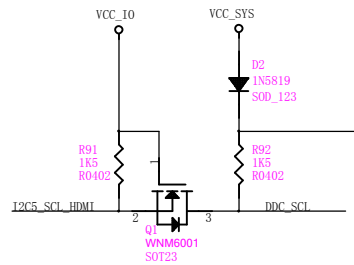
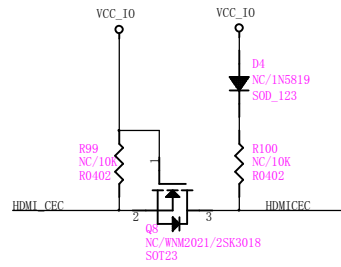

HDMI OUT

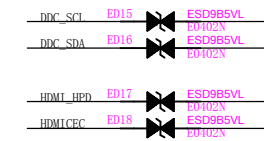
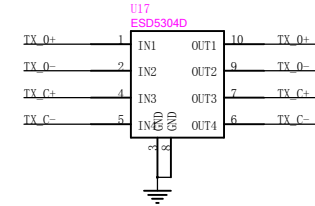
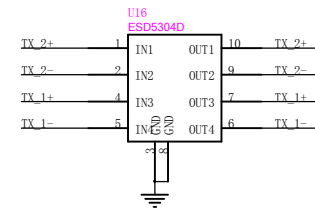

Firefly	
Title: HDMI OUT	
REV: 1.1	File:
Page Num:11	Create Date:
Page Total:21	Modify Date: Wednesday, June 18, 2014

U1-A
MCU_RK3288

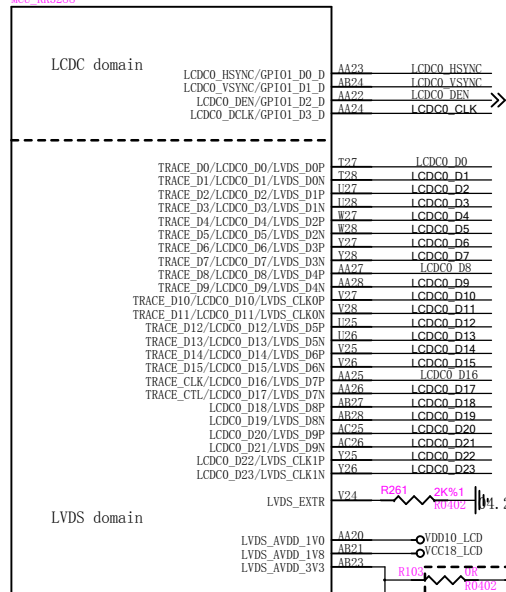

RK3288_A

VCC_IO Change to VCCA_33

RK3288_I

U1-I
MCU_RK3288

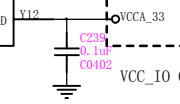
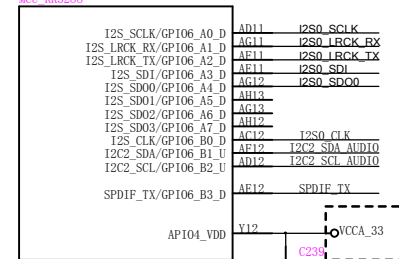

R103 suggest reserve cannot be deleted

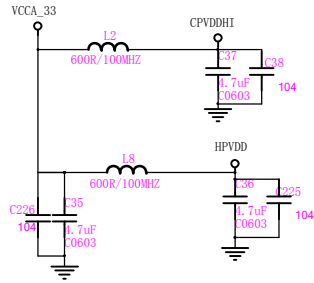
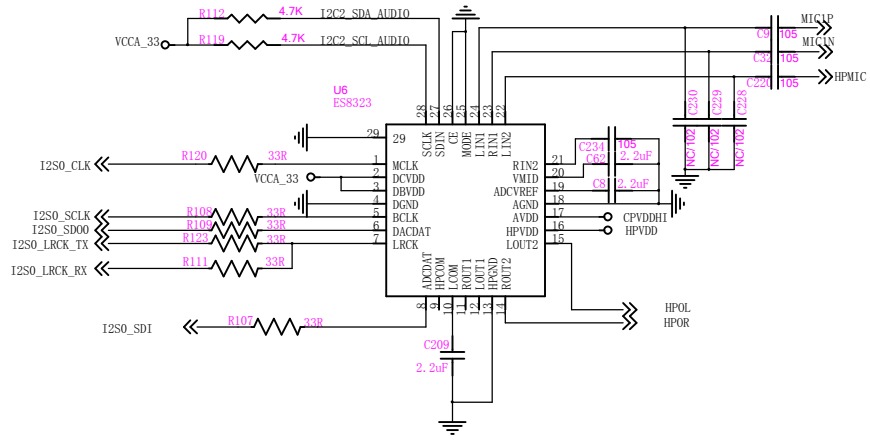

ES8323

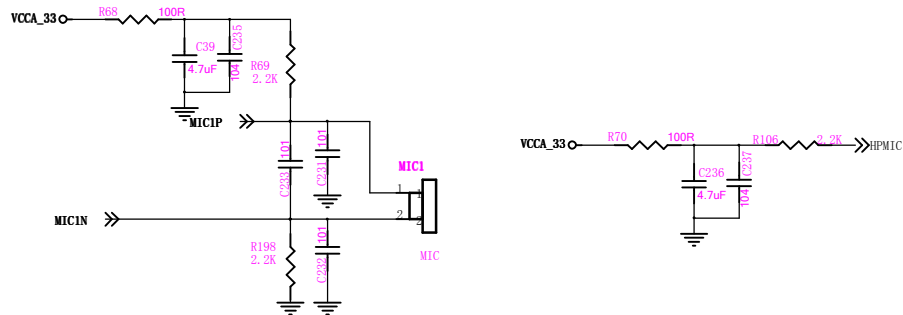

MIC

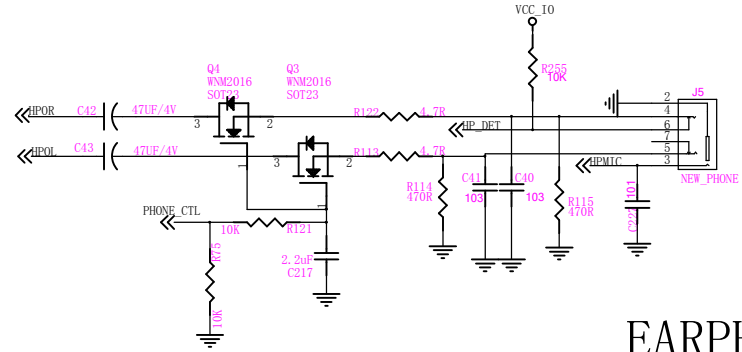

EARPHONE

Firefly	
Title:	ES8323
File:	REV:1.1
Create Date:	Page Num:13
Modify Date: Wednesday, June 18, 2014	Page Total: 21

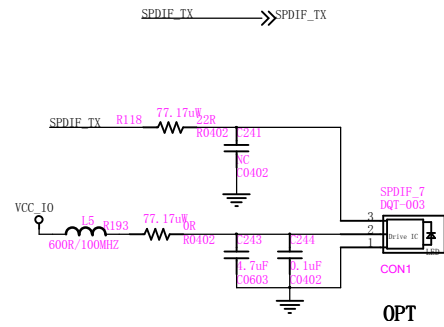

Optical S/PDIF OUT

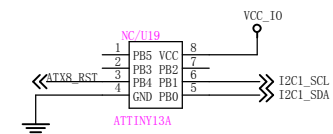
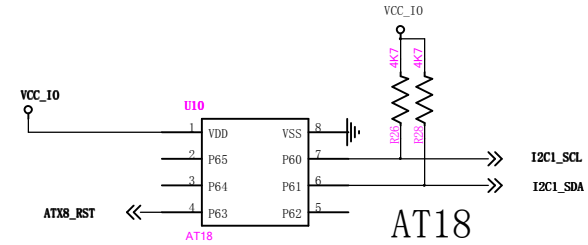

ATTINY13A

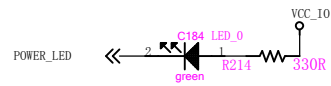

WORKING_LED

U1-Q
MCU RK3288

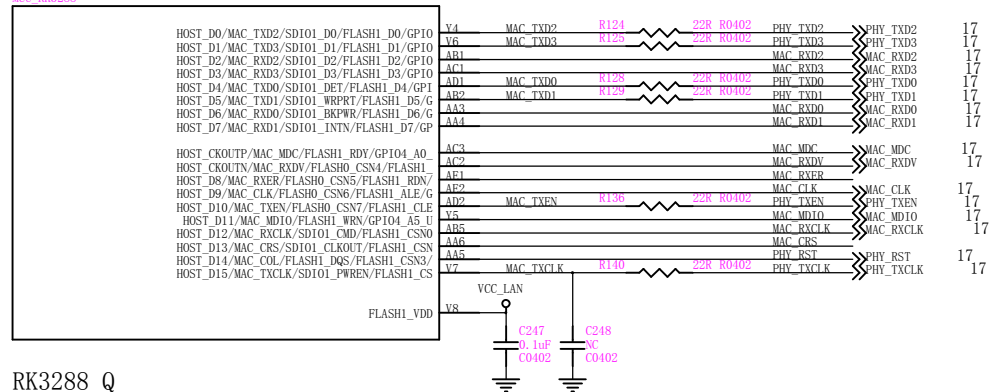

RK3288_Q

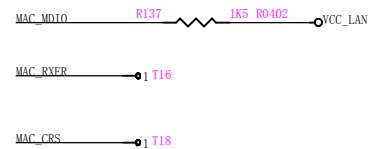

PHY_TXD0	16
PHY_TXD1	16
PHY_TXD2	16
PHY_TXD3	16
PHY_TXEN	16
PHY_TXCLK	16
MAC_RXD0	16
MAC_RXD1	16
MAC_RXD2	16
MAC_RXD3	16
MAC_RXDV	16
MAC_RXCLK	16
MAC_CLK	16
MAC_MDC	16
MAC_MDIO	16
PHY_RST	16
PHY_PMEB	11
PHY_INT	11

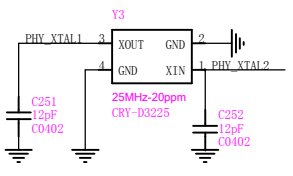

If use external clock then the XTAL2 need connect to GND for RTL8211E.

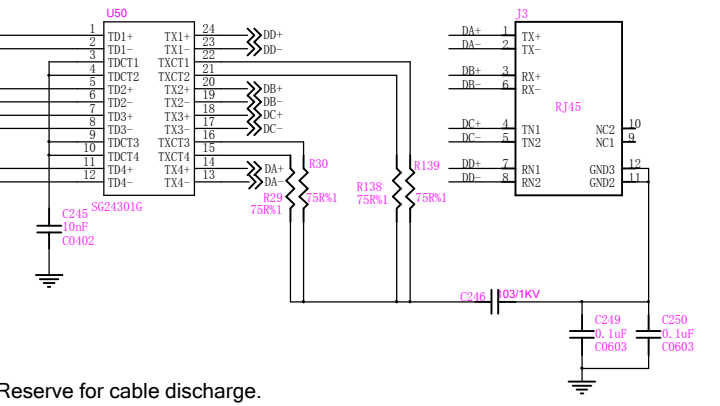
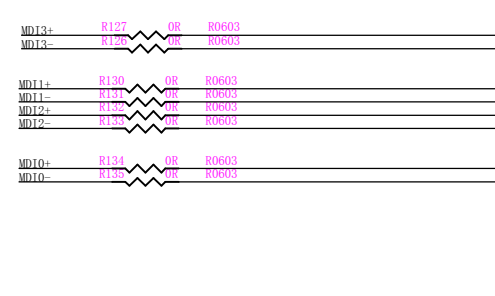
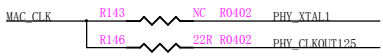

Reserve for cable discharge.

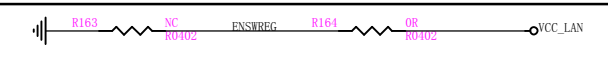
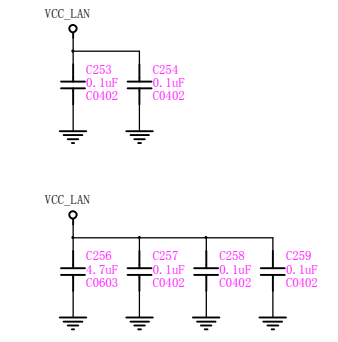
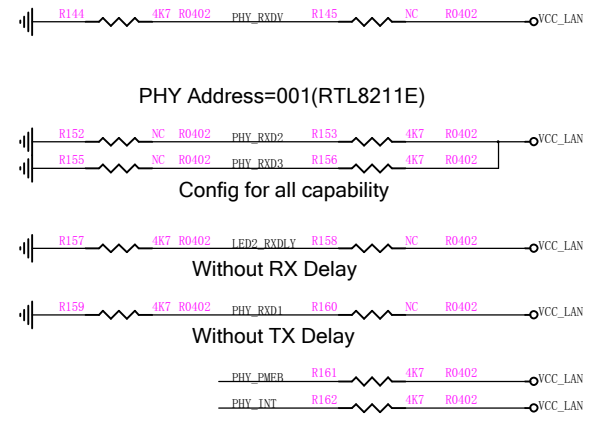
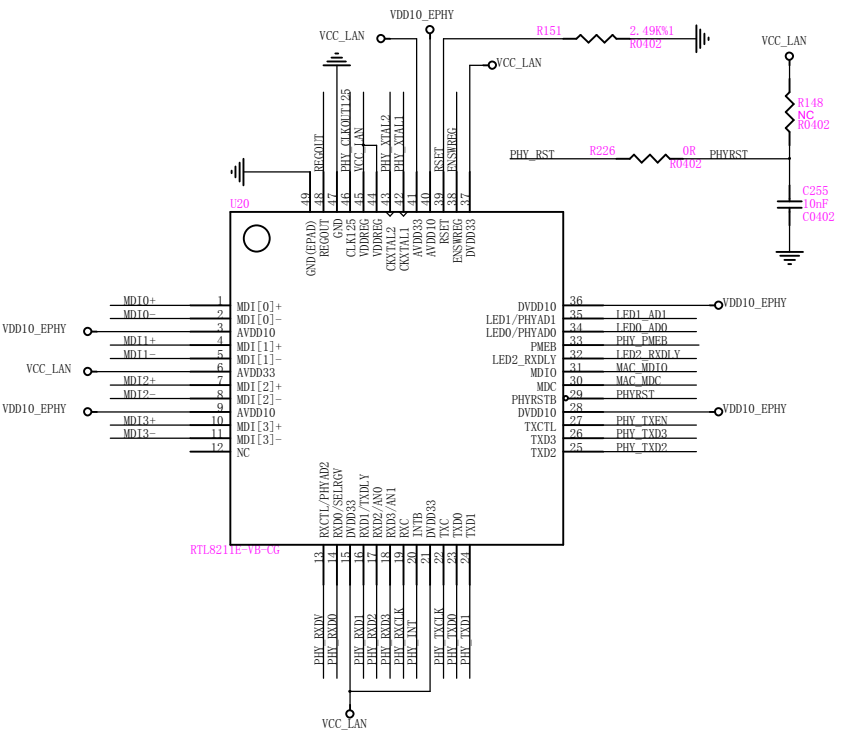

Connect ENSWREG to AVDD33 to enable Switching regulator or connect ENSWREG to GND to disable Switching regulator.

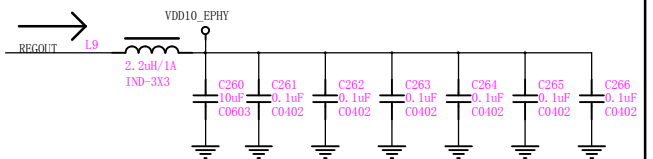

Inductance close to PIN48

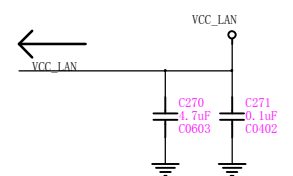

Close to PIN44.45

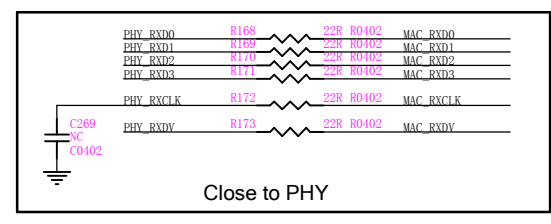

Close to PHY

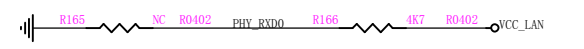

Pull down for 2.5V RGMII (RTL8211D/8211E)
Pull up for 3.3V RGMII (RTL8211D/8211E)
Pull up 1.5 / 1.8V RGMII (RTL8211E-VL only)

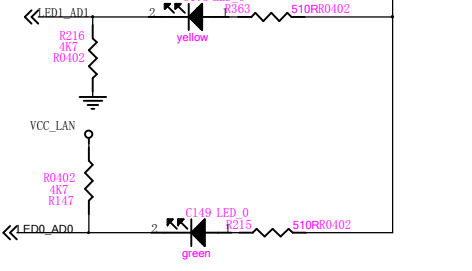

U1-H
MCU_RK3288

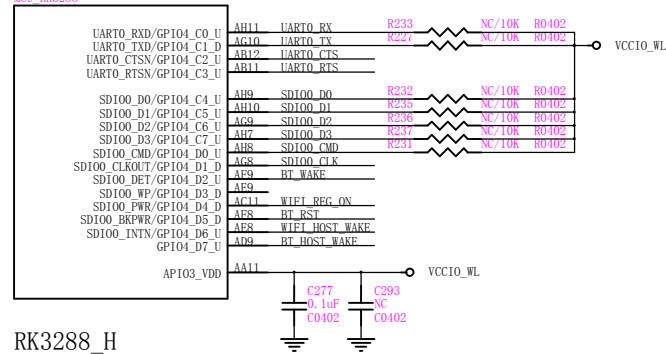

RK3288_H

UART0_RX	UART0_RX	19
UART0_TX	UART0_TX	19
UART0_CTS	UART0_CTS	19
UART0_RTS	UART0_RTS	19
SDIO0_D0	SDIO0_D0	19
SDIO0_D1	SDIO0_D1	19
SDIO0_D2	SDIO0_D2	19
SDIO0_D3	SDIO0_D3	19
SDIO0_CMD	SDIO0_CMD	19
SDIO0_CLK	SDIO0_CLK	19
BT_WAKE	BT_WAKE	19
WIFI_REG_ON	WIFI_REG_ON	19
BT_RST	BT_RST	19
WIFI_HOST_WAKE	WIFI_HOST_WAKE	19
BT_HOST_WAKE	BT_HOST_WAKE	19

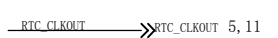
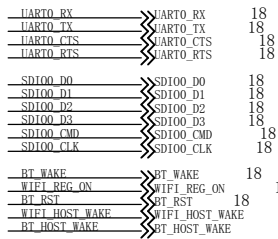

Note:
Adjusted the load capacitance according to the crystal specification.

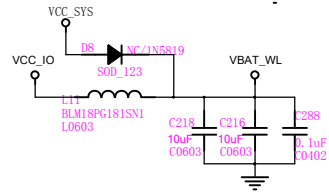
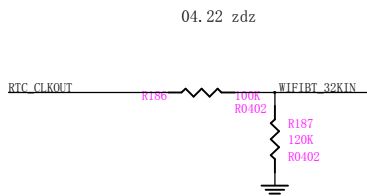
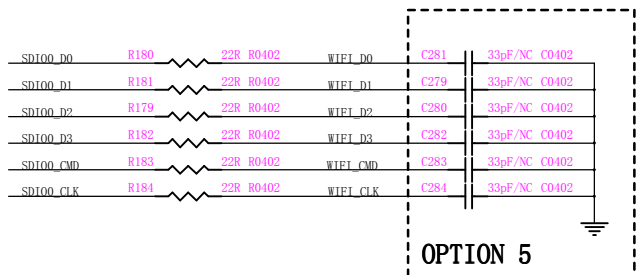

3.0V-4.8V
At least 400 ma power supply current

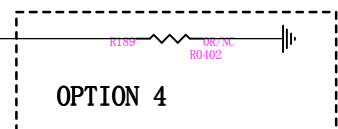
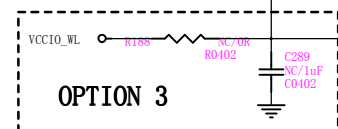
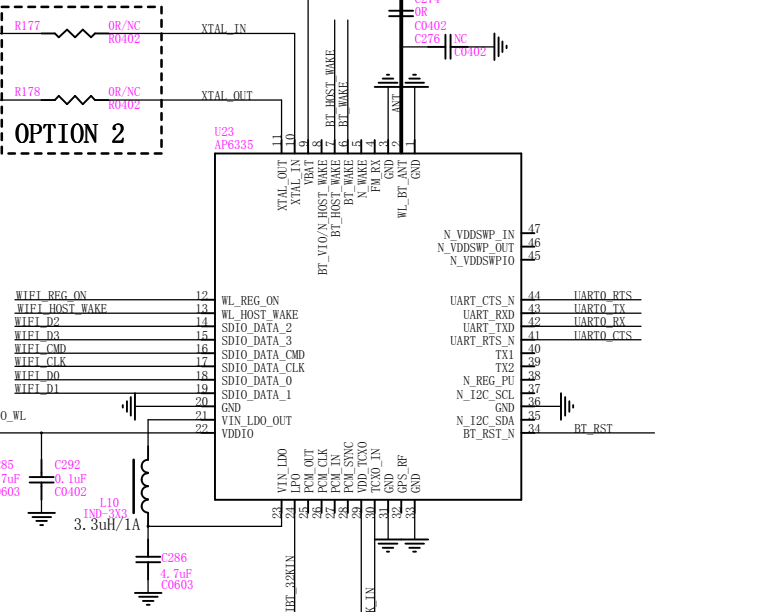
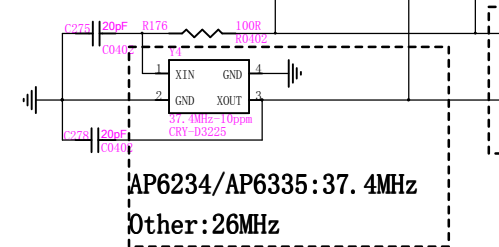
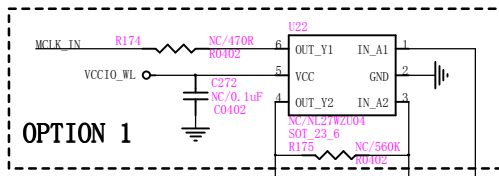

OPTION	WIFI			5GHz	BT4.0	Crystals	VDDIO
	a	b/g/n	ac				
AP6181		Yes				26MHz	1.71-3.6V
AP6210		Yes			Yes	26MHz	1.71-3.6V
AP6234	Yes	Yes		Yes	Yes	37.4MHz	1.6-3.4V
AP6330	Yes	Yes		Yes	Yes	26MHz	1.2-2.9V
AP6335 (Default)	Yes	Yes	Yes	Yes	Yes	37.4MHz	1.71-3.63V

OPTION	BT				
	1	2	3	4	5
AP6181	No	Yes	No	No	No
AP6210	Yes	No	Yes	No	No
AP6234	No	Yes	No	No	No
AP6330	No	Yes	No	No	No
AP6335 (Default)	No	Yes	No	Yes	Yes

Note:
Yes: Inside the box to
No: The box is not posted

Firefly	
Title: AP6XXX-WIFI/BT	REV:1.1
Create Date:	Page Num: 18
Modify Date: Wednesday, June 18, 2014	Page Total: 21

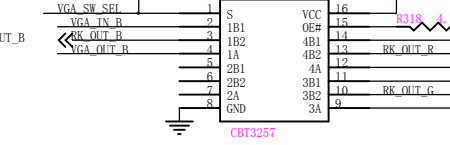
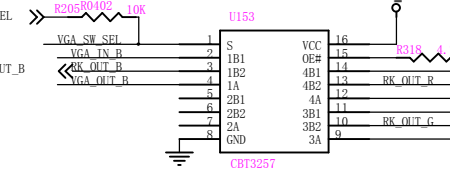
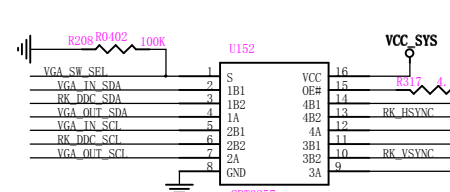
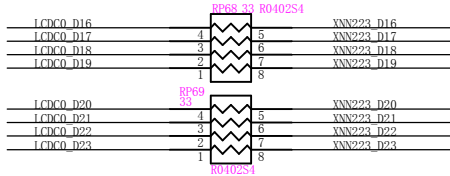
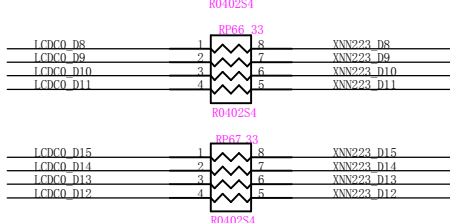
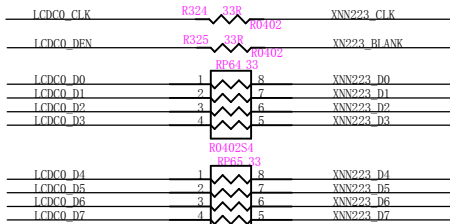
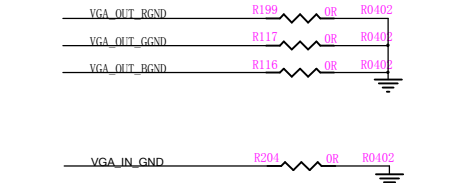
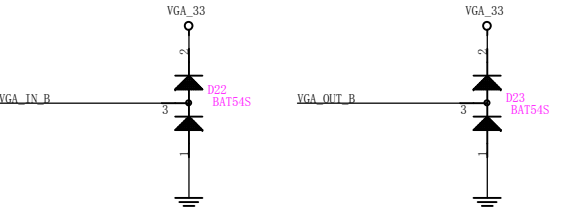
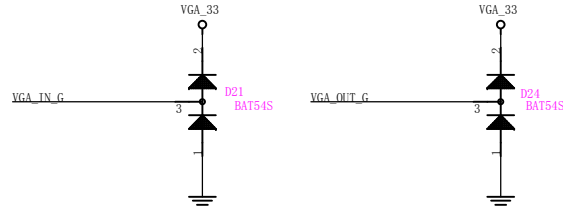
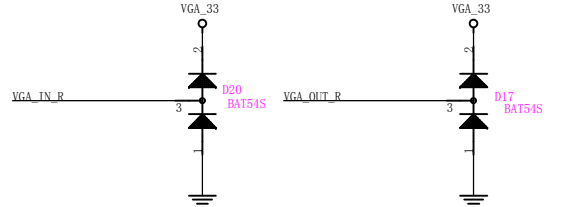
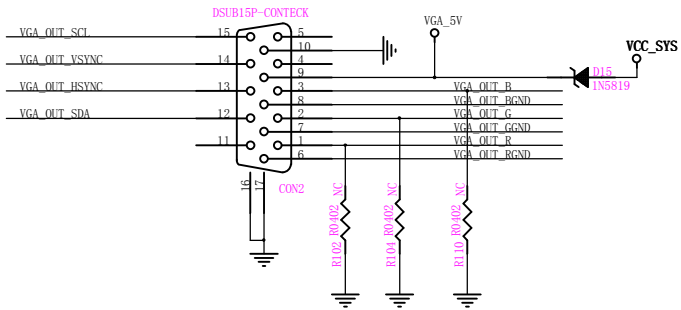

VGA_SEL	Function
High	VGA_OUT=RK_OUT
Low(Default)	VGA_OUT=VGA_IN

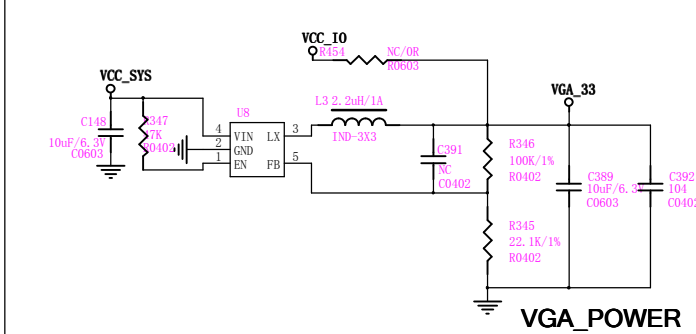
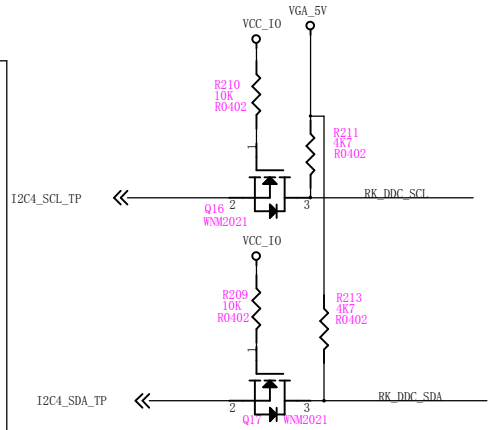
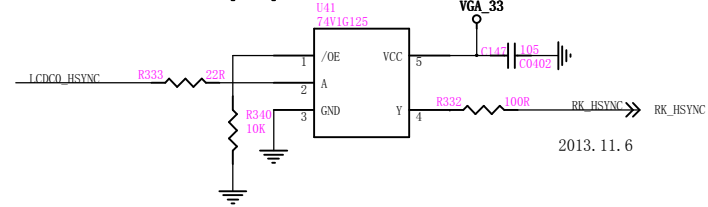
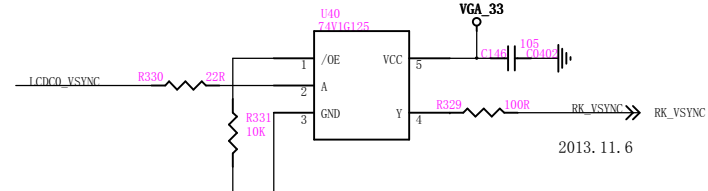
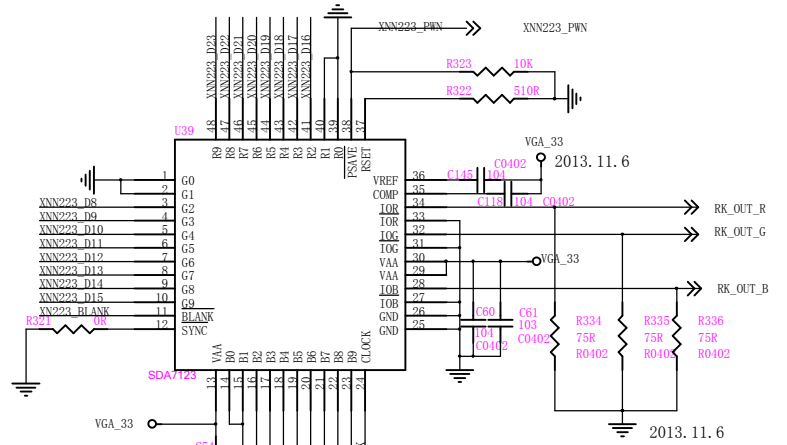

Firefly	
Title: VGA	REV:1.1
File:	Page Num: 19
Create Date:	Page Total: 21
Modify Date: Wednesday, June 18, 2014	

U1-C
MCU RK3288

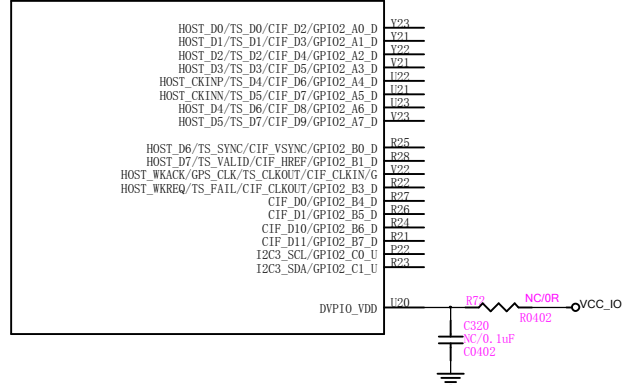

RK3288_C

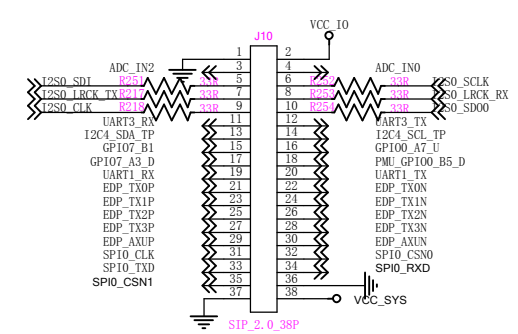
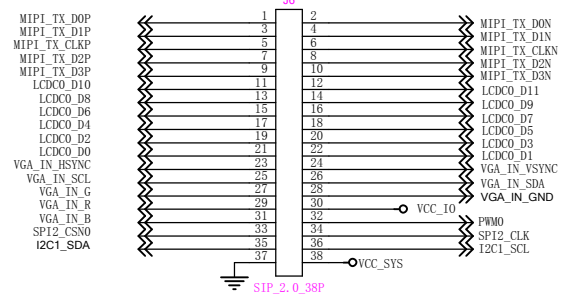

U1-W
MCU RK3288

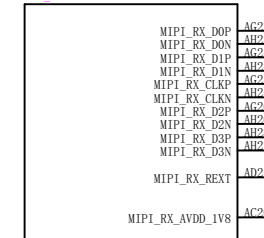

RK3288_W

U1-X
MCU RK3288

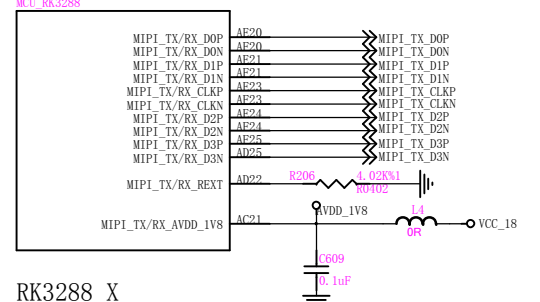

RK3288_X

U1-N
MCU RK3288

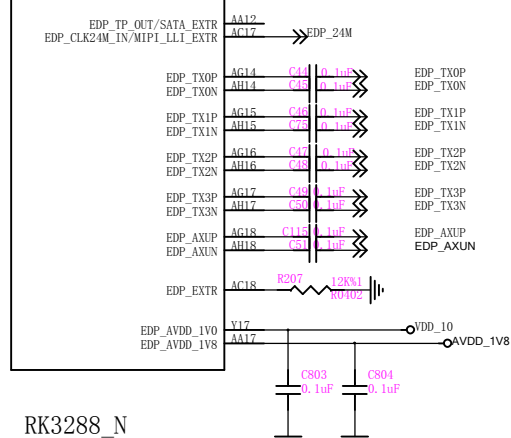

RK3288_N

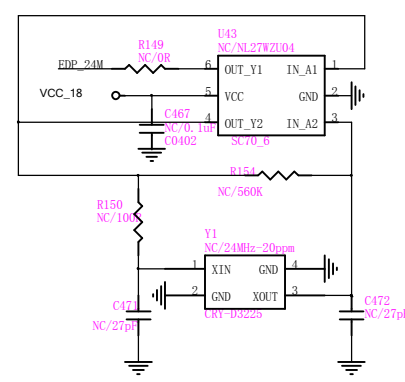

U1-V
MCU RK3288

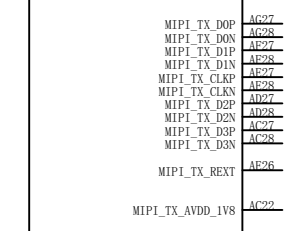

RK3288_V

Firefly	
Title:	Camera Interface
File:	REV:1.1
Create Date:	Page Num: 20
Modify Date: Wednesday, June 18, 2014	Page Total: 21

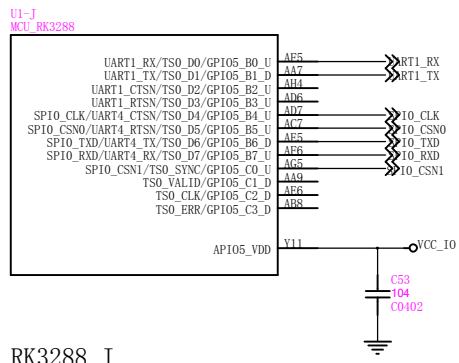

RK3288_J

Firefly	
Title: DTV-(Reserve)	
File:	REV:1.1
Create Date:	Page Num: 21
Modify Date: Wednesday, June 18, 2014	Page Total: 21