

Content Indexing

- 01.Index
- 02.Modify note
- 03.Block Diagram
- 04.Power Tree
- 05.System Power
- 06.RK3288 USB/HSIC Controler
- 07.USB HOST Port
- 08.RK3288 RAM Controler
- 09.RAM-DDR3-4X16bit
- 10.Nand FLASH/eMMC/TF Card
- 11.RK3288 GPIO/POWER
- 12.HDMI OUT
- 13.RK3288 LCDC/I2S Controler
- 14.RK1000-S-AV OUT
- 15.S/PDIF OUT
- 16.RK3288 Ethernet MAC Controler
- 17.10/100/1000M-PHY
- 18.RK3288 SDIO0 Controler
- 19.AP6XXX-WIFI/BT
- 20.VGA
- 21.Camera Interface
- 22.DTV-(Reserve)

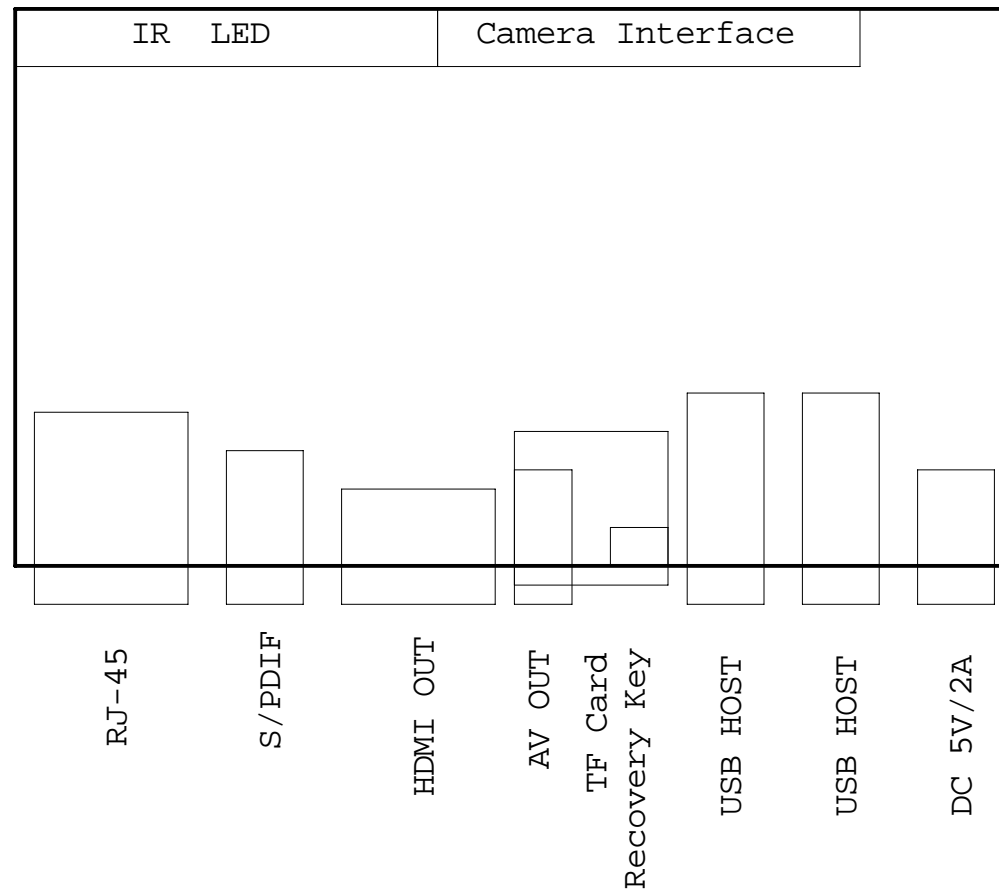

6 LAYERS PCB STACK

TOP(Signal1) _____ Cu,thickness:0.7mil,Plating to 1oz

GND1 _____ FR4,thickness:3.8mil,Dielectric Constant:4.3 Cu,thickness:1.5mil, 1oz

POWER _____ FR4,thickness:8mil,Dielectric Constant:4.3 Cu,thickness:1.5mil, 1oz

FR4,thickness:adjust thickness according to the thickness of board ,Dielectric Constant:4.3

Signal2 _____ FR4,thickness:8mil,Dielectric Constant:4.3 Cu,thickness:1.5mil, 1oz

GND2 _____ FR4,thickness:3.8mil,Dielectric Constant:4.3 Cu,thickness:1.5mil, 1oz

BOTTOM(Signal3) _____ FR4,thickness:3.8mil,Dielectric Constant:4.3 Cu,thickness:0.7mil,Plating to 1oz

Firefly

Title: Index

File:

REV: 1.1

Create Date:

Page Numr 1

Modify Date: Wednesday, June 18, 2014

Page Total: 21

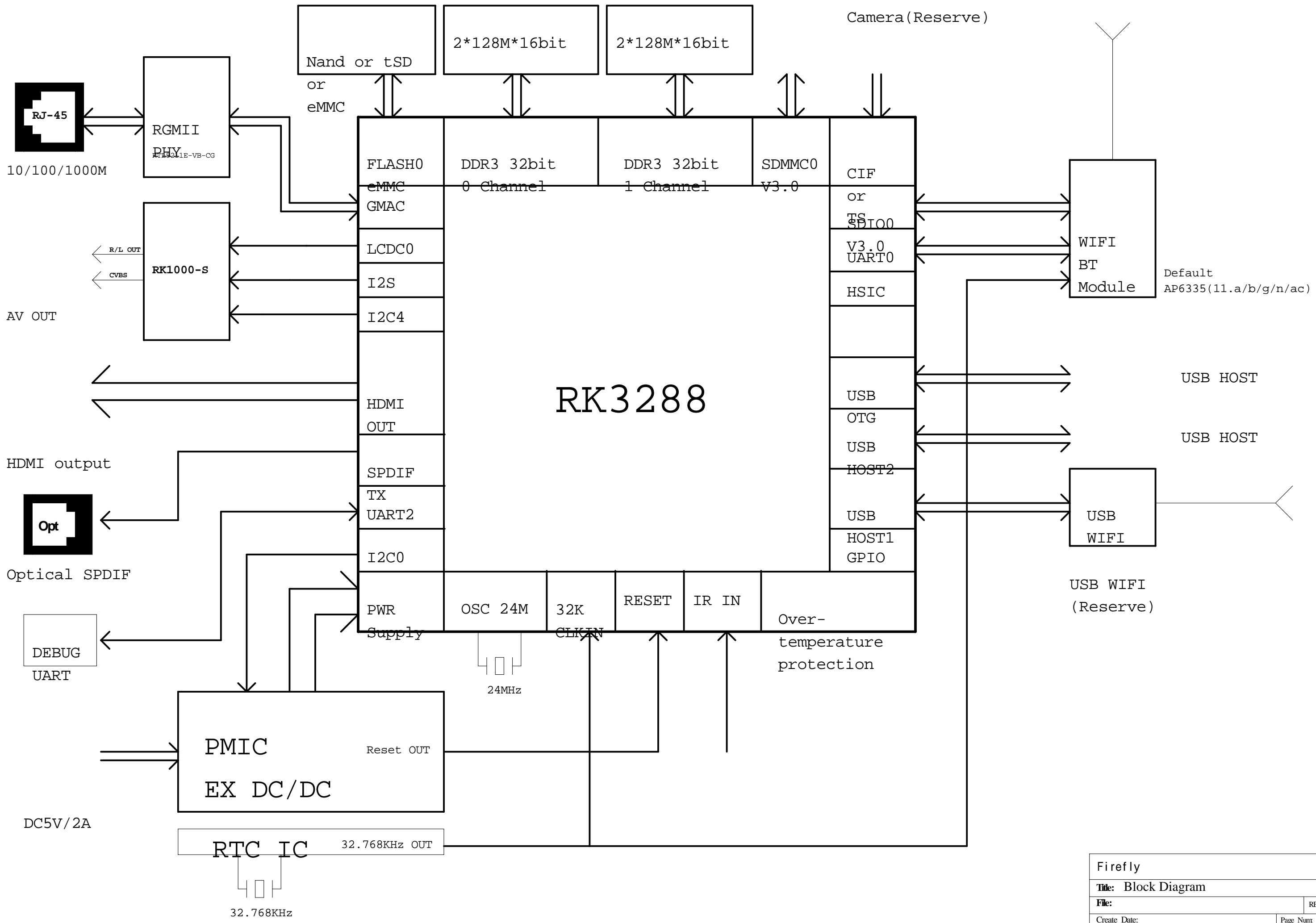

Firefly	
Title: Block Diagram	
File:	REV: 1.1
Create Date:	Page Num: 2
Modify Date: Wednesday, June 18, 2014	Page Total: 21

ACT8846QM489

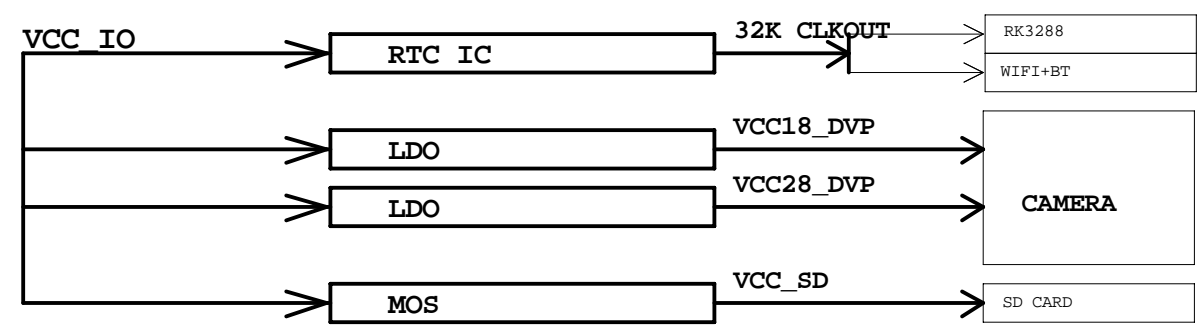
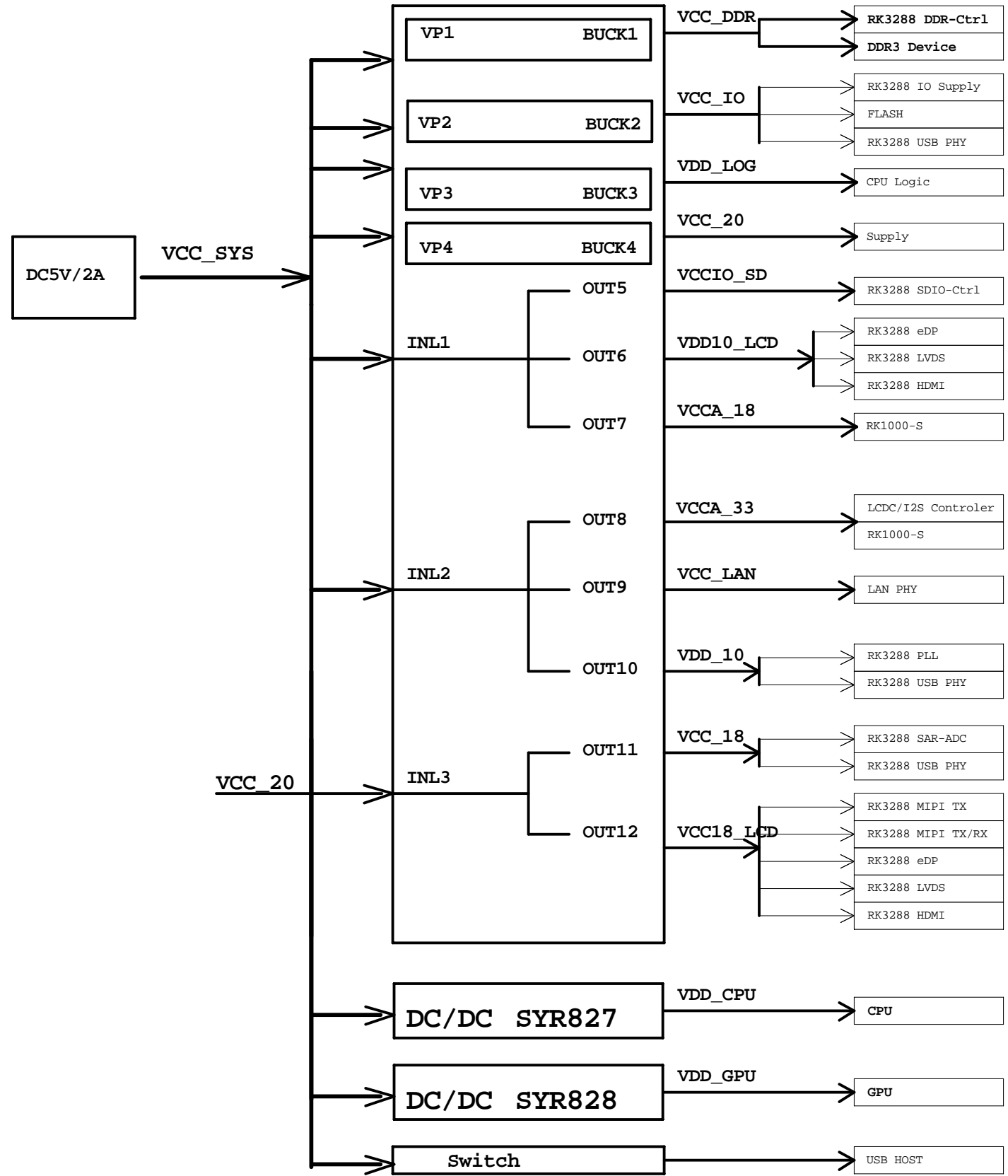

PowerName	PMIC Channel	timer(2mS)	Default	Working
VCC_20	DCDC4	Solt:0	voltage 2.0V	voltage 2.0V
VDD_10	OUT10	Solt:1	1.0V	1.0V
VCC_DDR	DCDC1	Solt:2	1.5V	1.5V(DDR3)
VDD_CPU	EX DCDC	Solt:2A	1.5V(1.2V)	DVFS
VDD_GPU	EX DCDC	Solt:2B	1.0V	DVFS
VDD_LOG	DCDC3	Solt:3	1.1V	DVFS
VCC_18	OUT11	Solt:4	1.8V	1.8V
VCC_LAN	OUT9	Solt:5	3.3V	3.3V
VCC_IO	DCDC2	Solt:6	3.3V	3.3V
VCCIO_SD	OUT5	Solt:6	3.3V	SD2.0:3.3V
VCCA_33	OUT8	OFF	OFF	SD3.0:1.8V
VCCA_18	OUT7	OFF	OFF	1.8V
VDD10_LCD	OUT6	OFF	OFF	1.0V
VCC18_LCD	OUT12	OFF	OFF	1.8V

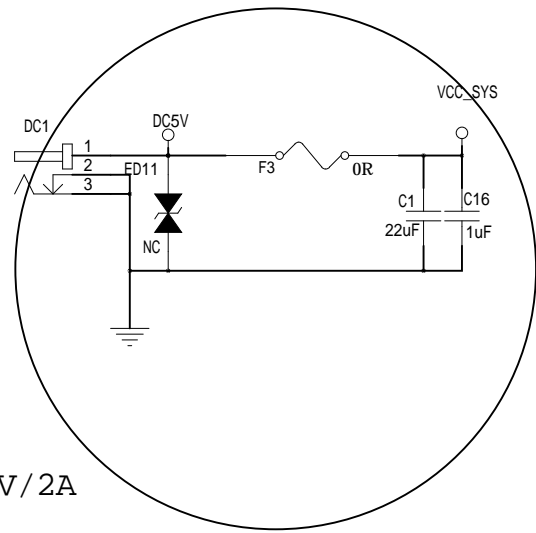

5V/2A

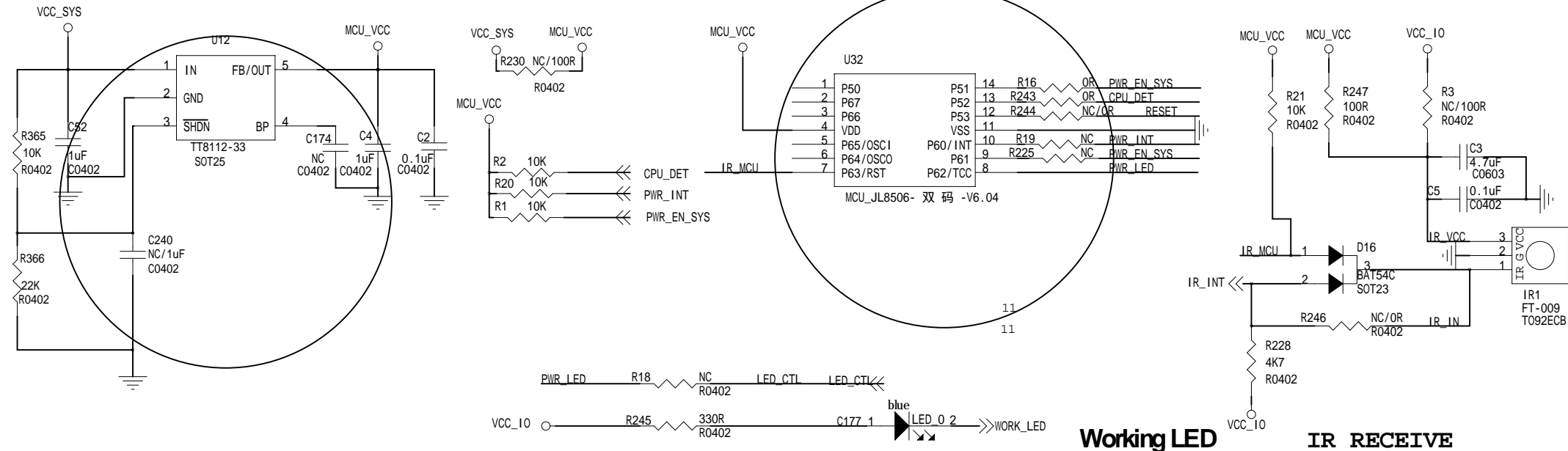

Working LED

IR RECEIVE

SYSTEM POWER

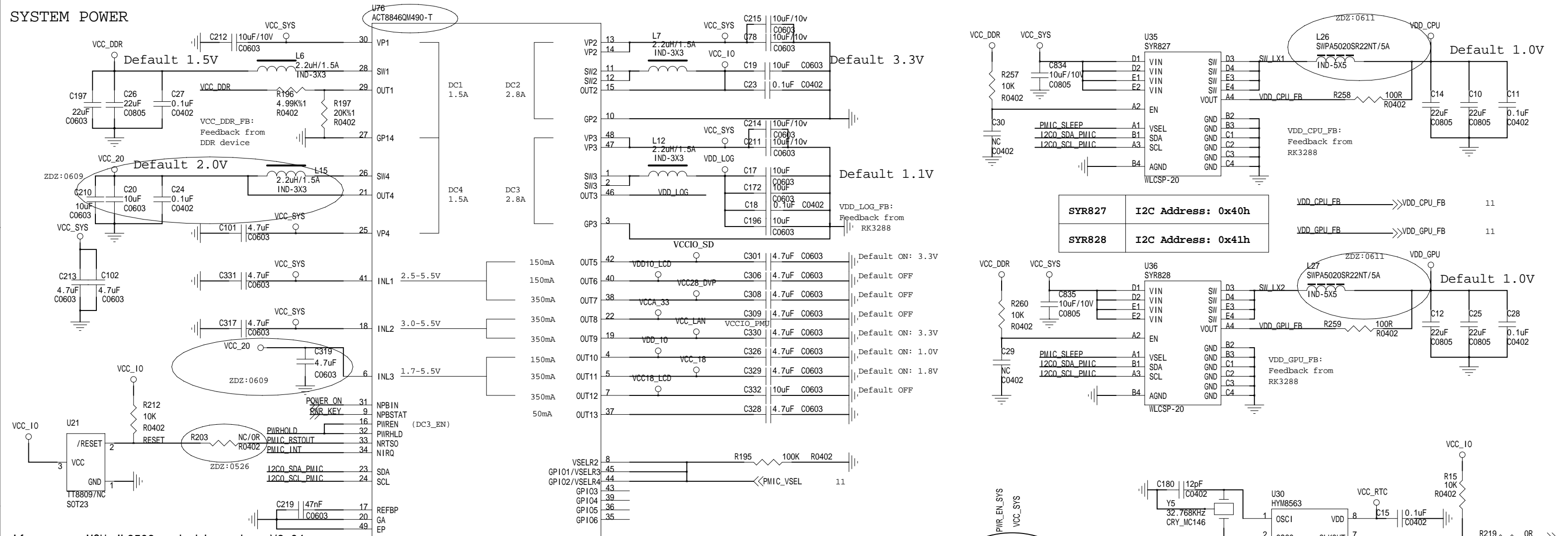

SYR827	I2C Address: 0x40h
SYR828	I2C Address: 0x41h

If you use MCU_JL8506 - double code - V6.04
Need to use external reset IC.
R203 don't stick.

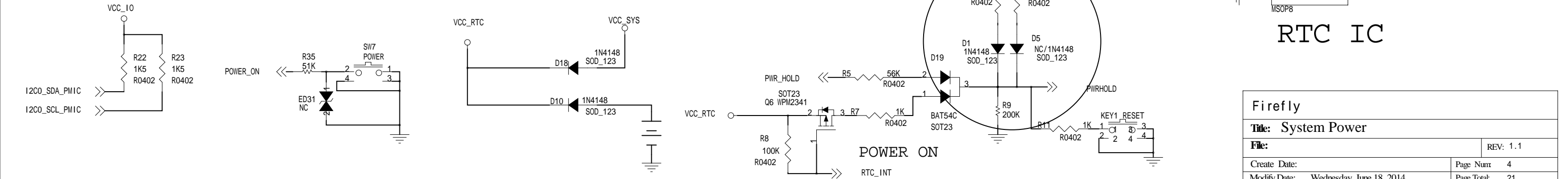

RTC IC

Firefly	
Title: System Power	
File:	REV: 1.1
Create Date:	Page Num: 4
Modify Date: Wednesday, June 18, 2014	Page Total: 21

U1-E
MCU_RK3288

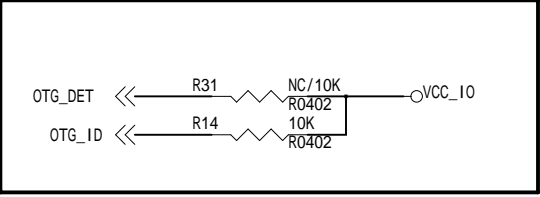
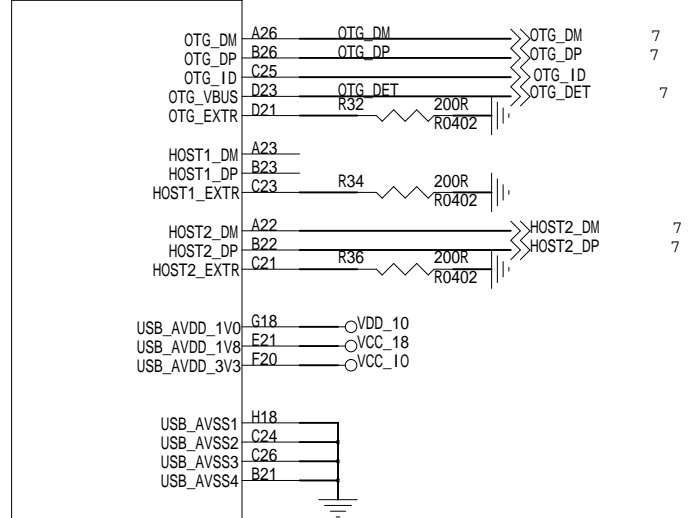

RK3288_E

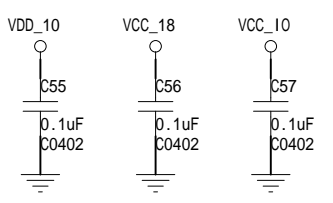

U1-U
MCU_RK3288

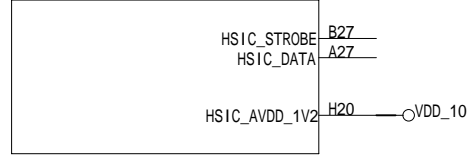

RK3288_U

Firefly	
Title: RK3288 USB/HSIC Controller	
File:	REV: 1.1
Create Date:	Page Numr 5
Modify Date: Wednesday, June 18, 2014	Page Total: 21

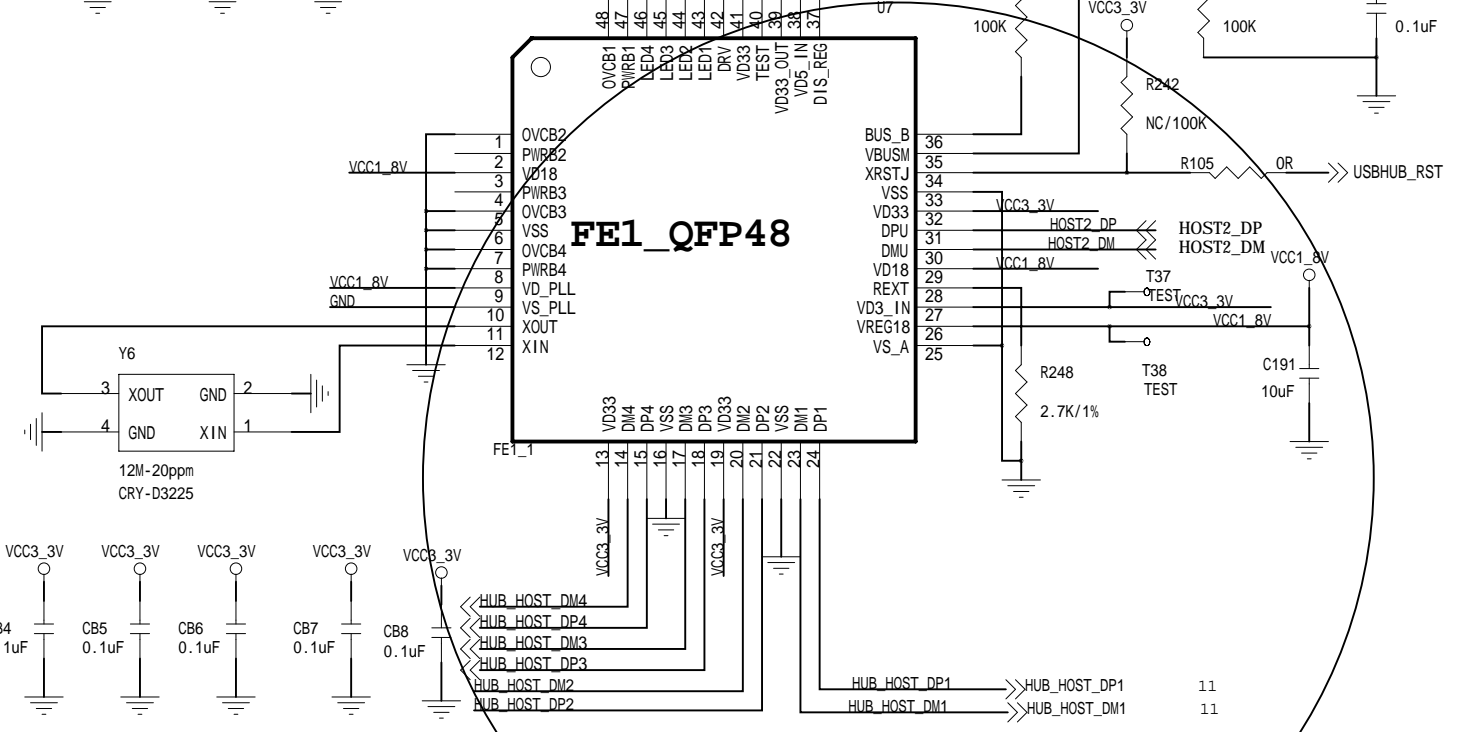
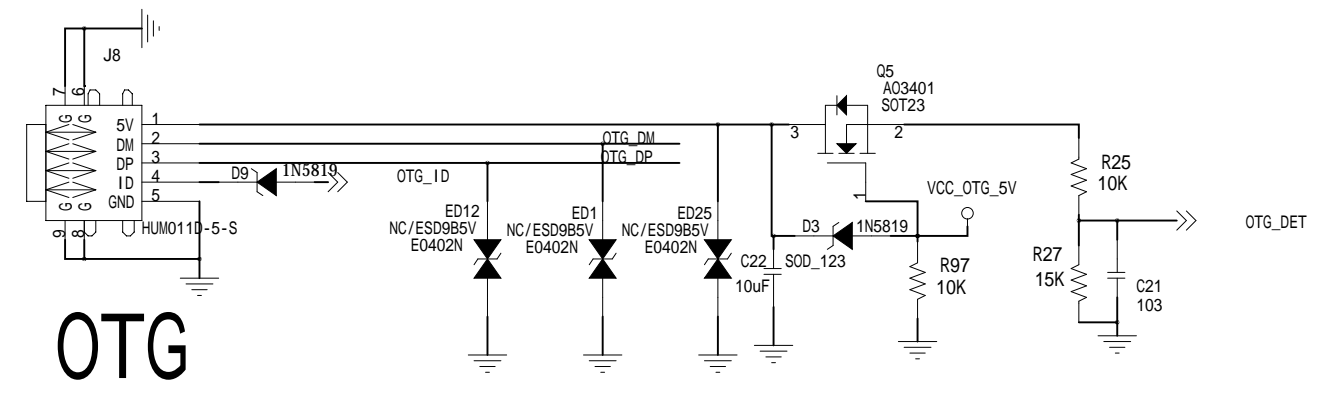
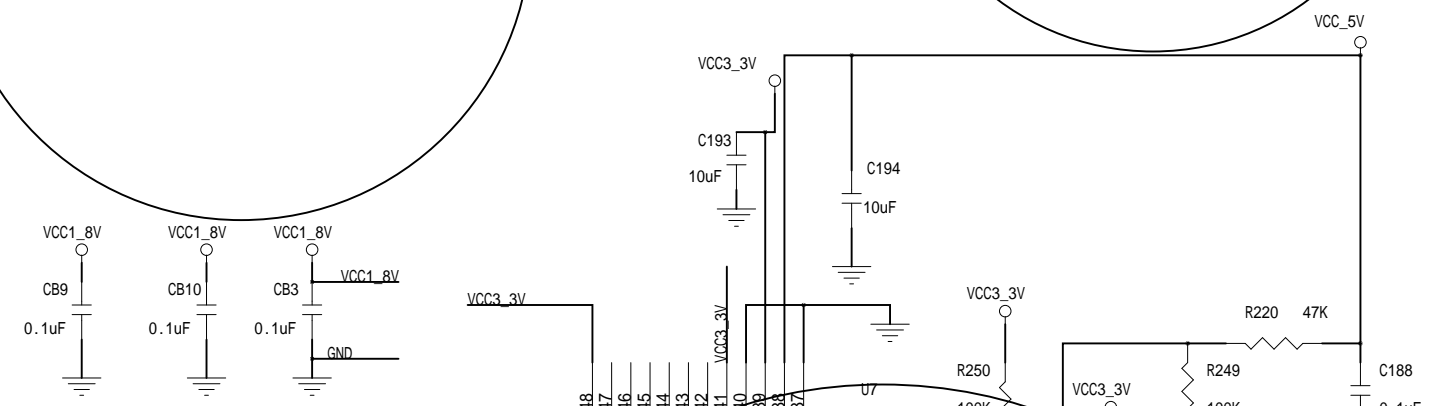
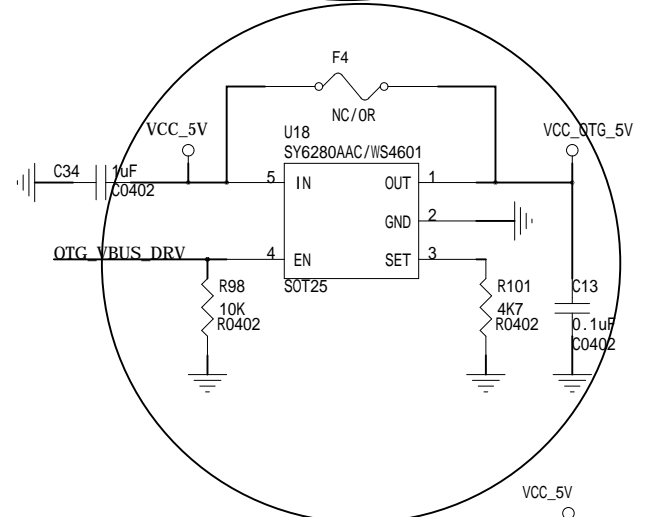
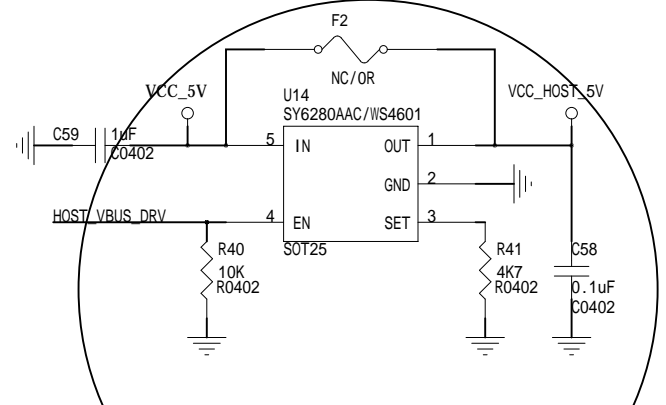
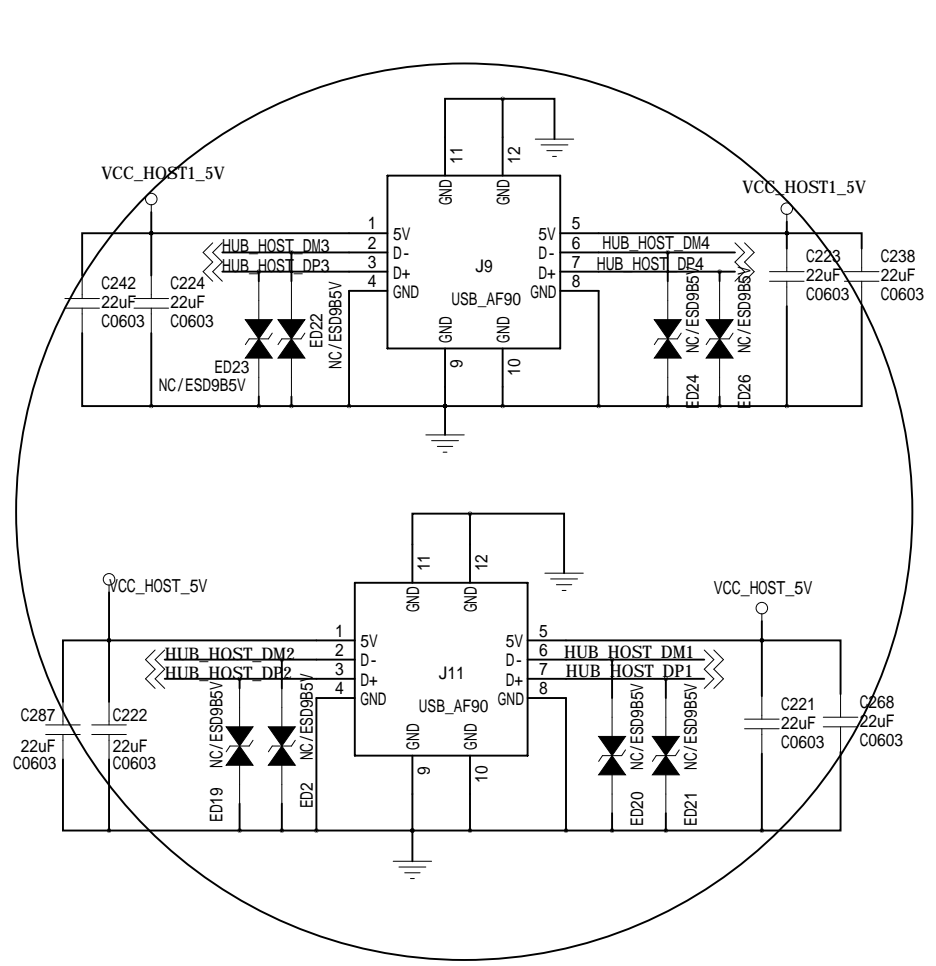
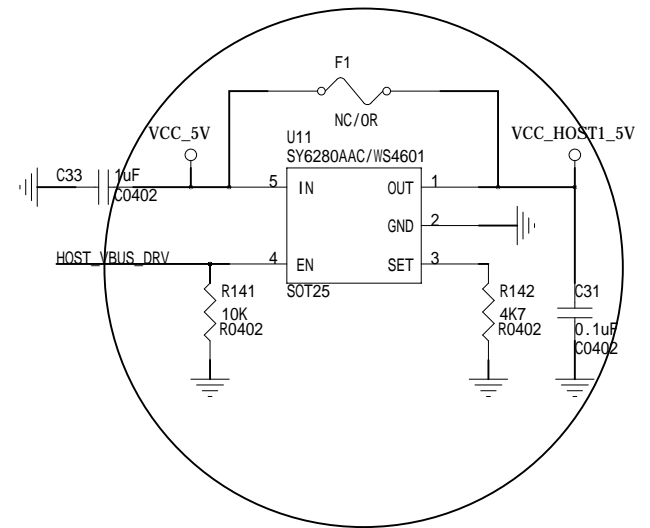
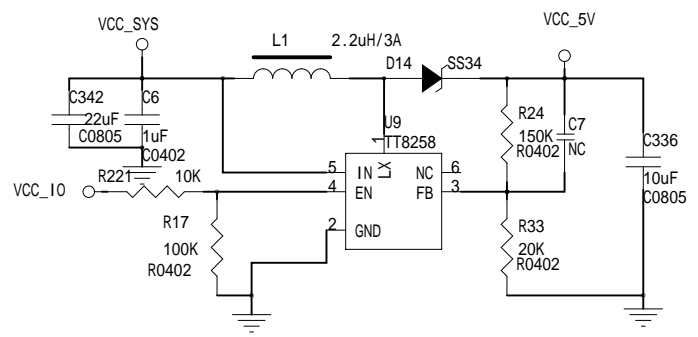

HUB CHIP

OTG

Firefly	
Title: USB HOST	
File:	REV: 1.1
Create Date:	Page Numr: 6
Modify Date: Wednesday, June 18, 2014	Page Total: 21

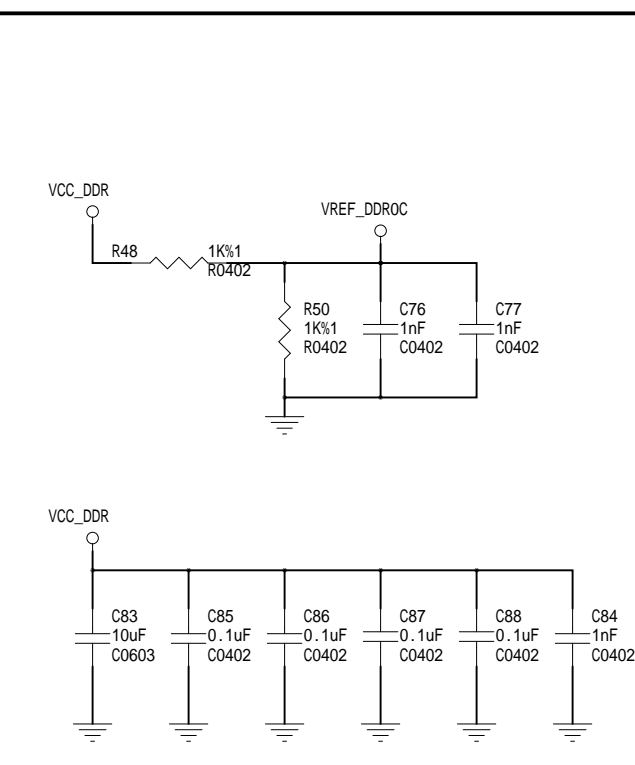
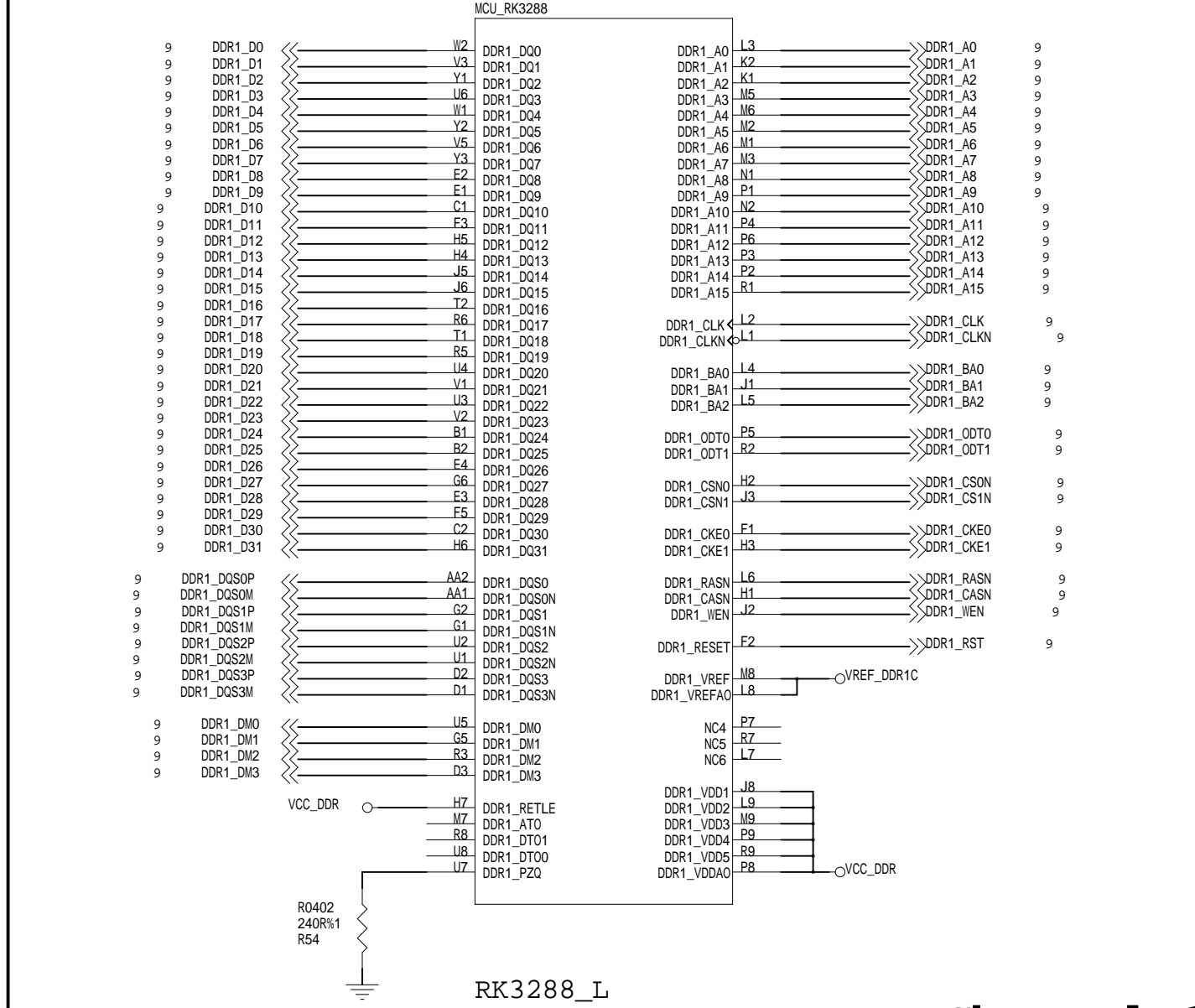
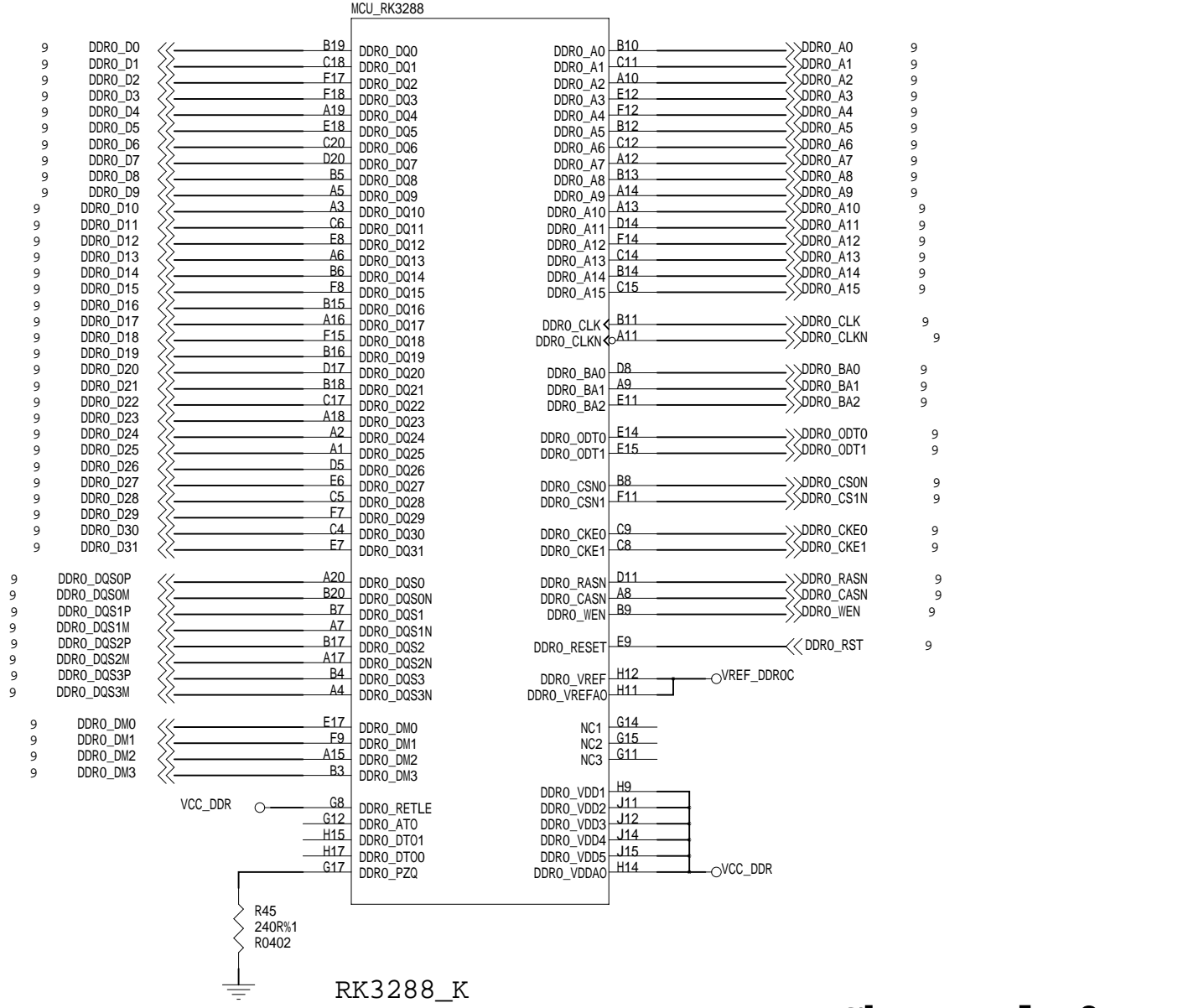

Note:
These termination resistors must be placed in the middle of trace, and the termination resistor of CLK must be placed in the bifurcation point.

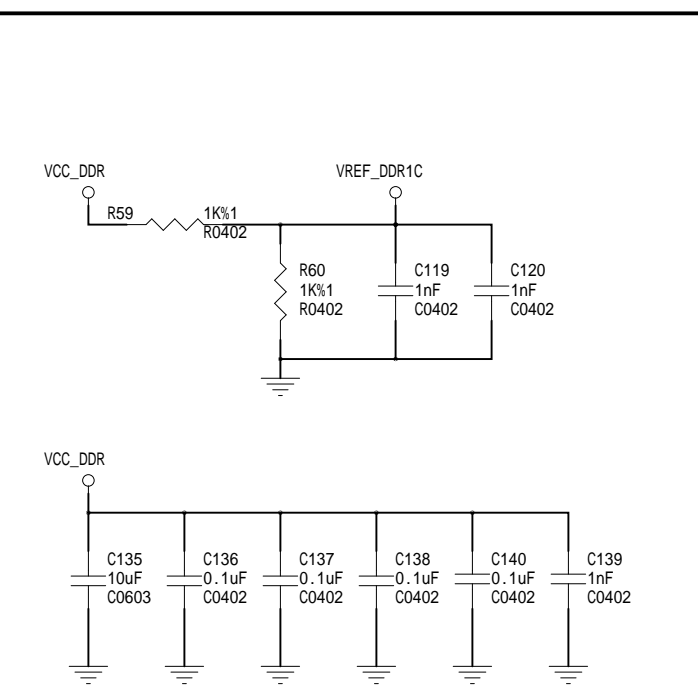

Note:
These termination resistors must be placed in the middle of trace, and the termination resistor of CLK must be placed in the bifurcation point.

Firefly	
Title: RK3288 RAM Controller	
File:	REV: 1.1
Create Date:	Page Num 7
Modify Date: Wednesday, June 18, 2014	Page Total 21

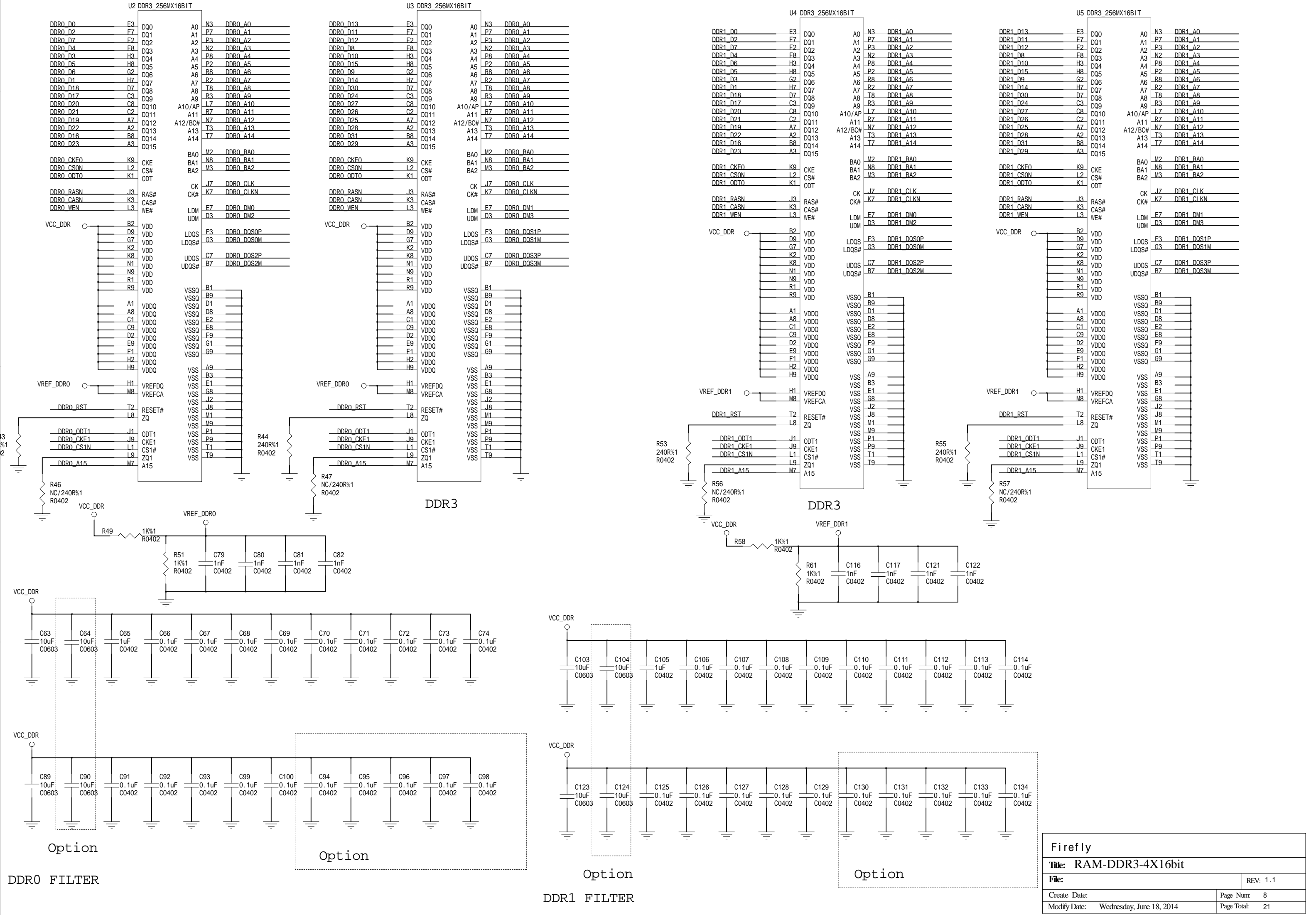

Firefly	
Title: RAM-DDR3-4X16bit	
File:	REV: 1.1
Create Date:	Page Num: 8
Modify Date: Wednesday, June 18, 2014	Page Total: 21

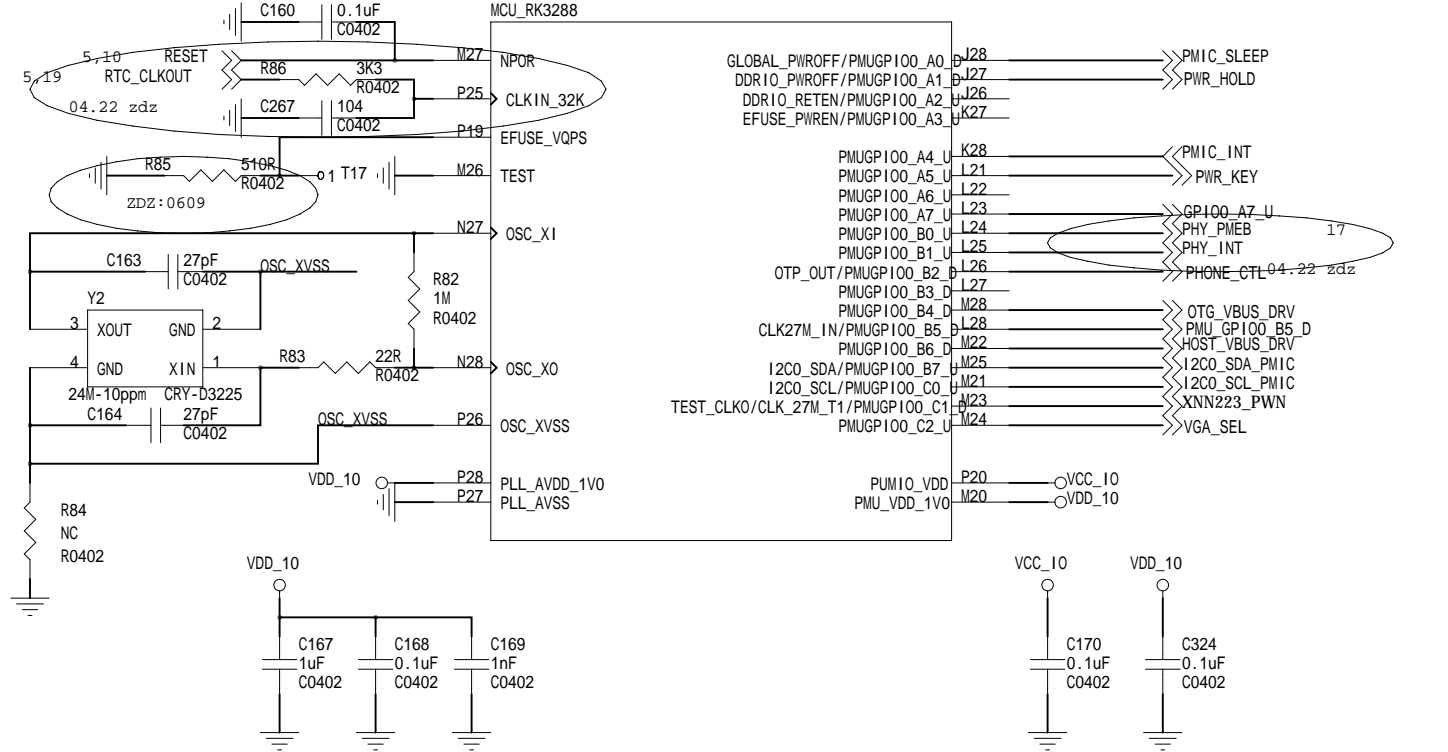

RK3288_D

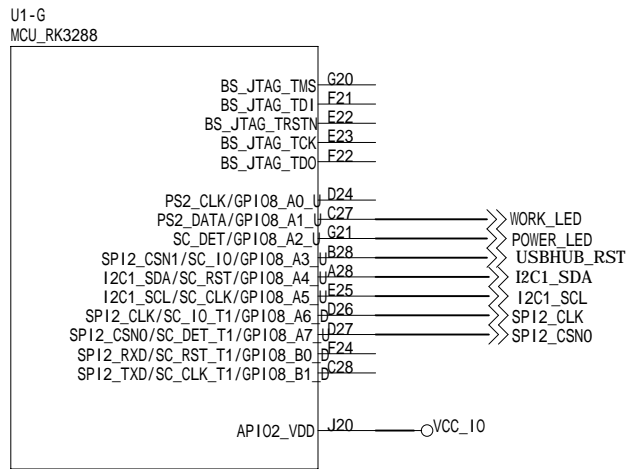

RK3288_G

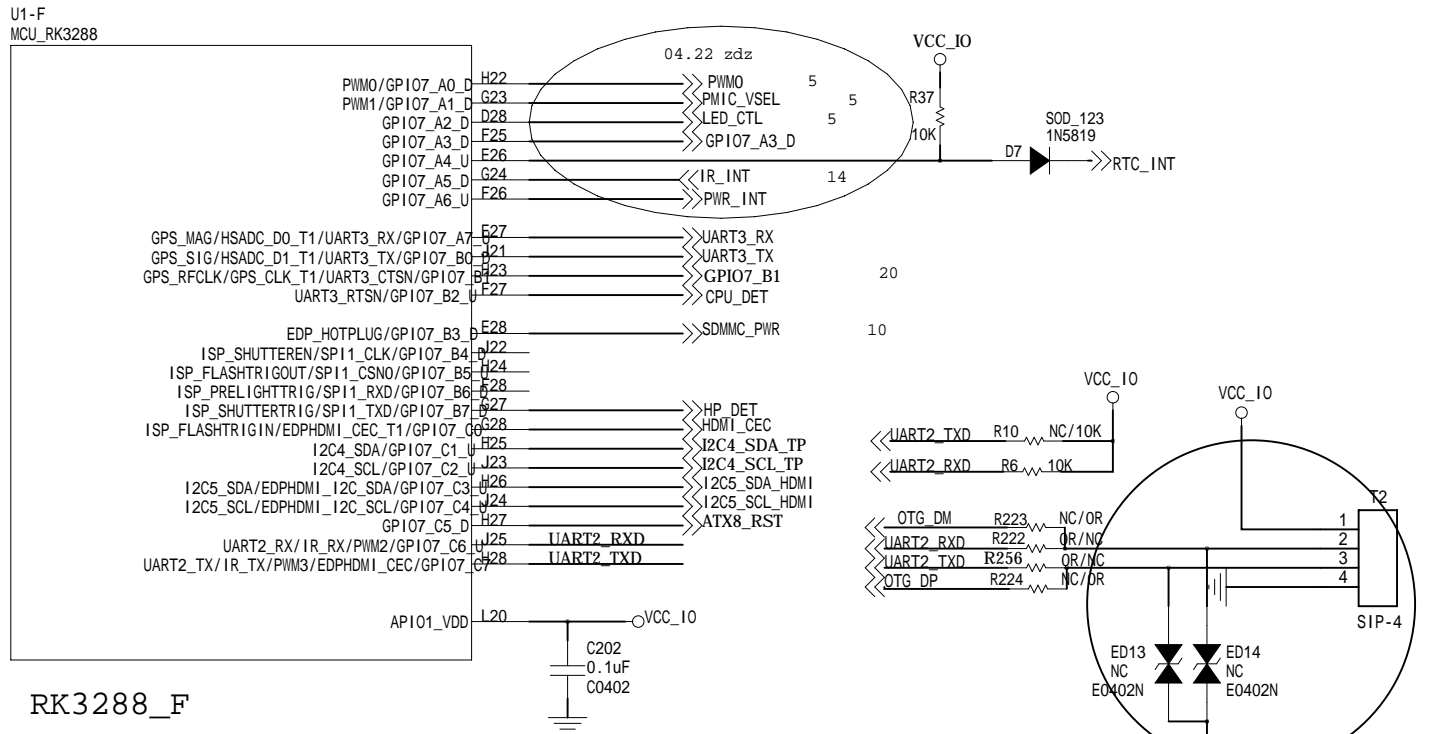

RK3288_F

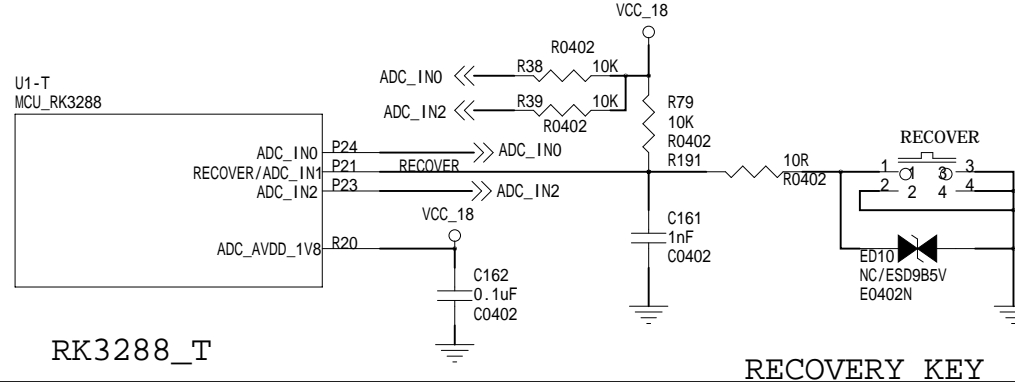

RK3288_T

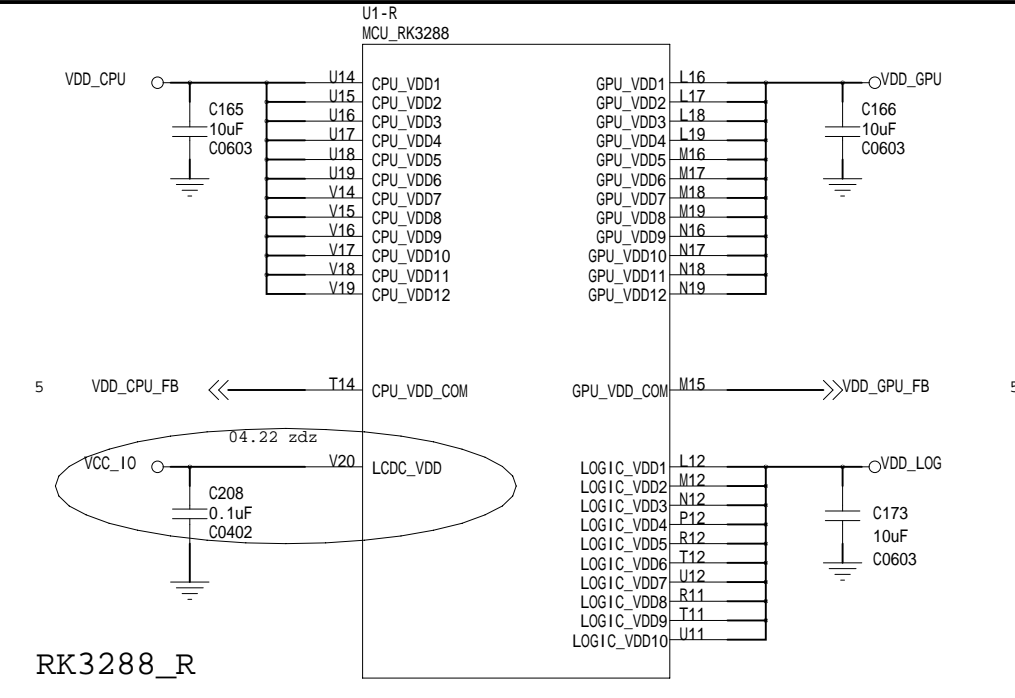

RK3288_R

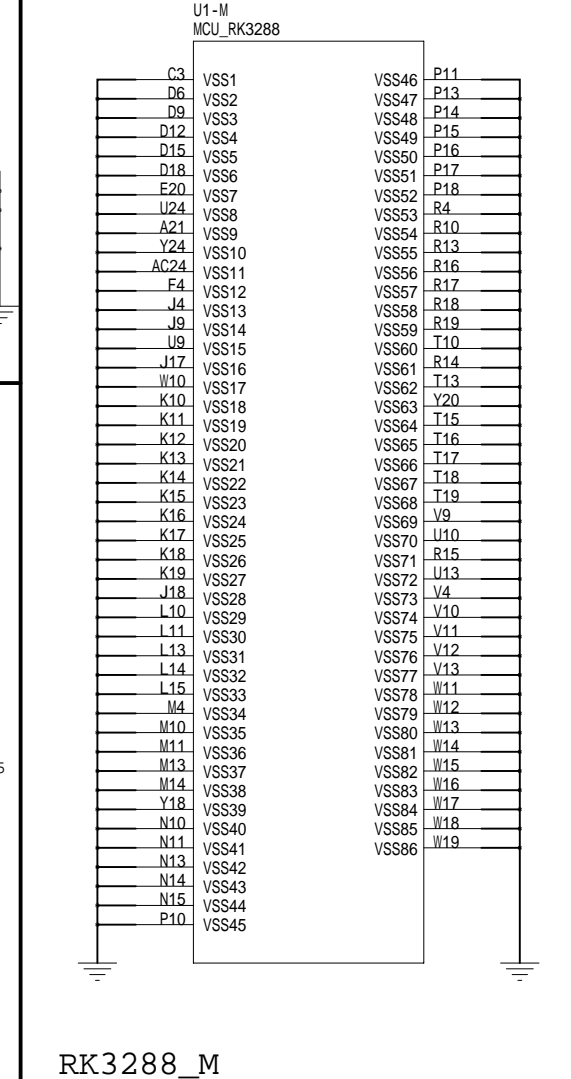

RK3288_M

RK3288 FILTER

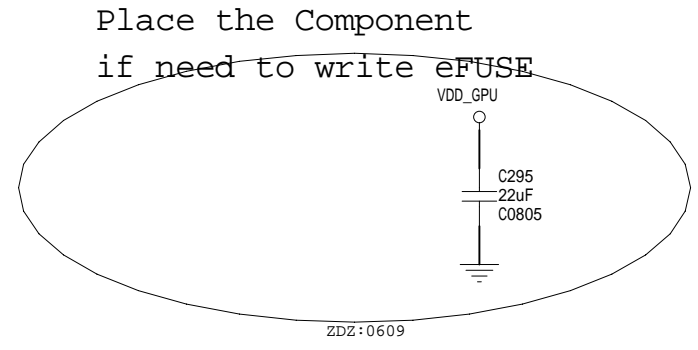
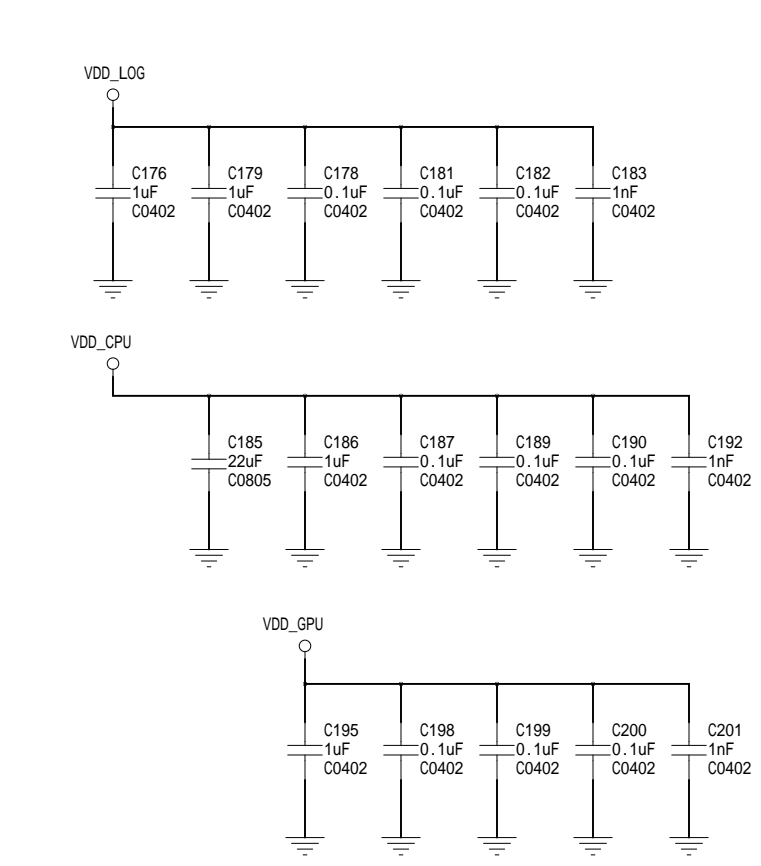

Firefly	
Title: RK3288 GPIO/POWER	
File:	REV: 1.1
Create Date:	Page Num: 10
Modify Date: Wednesday, June 18, 2014	Page Total: 21

U1-0
MCU_RK3288

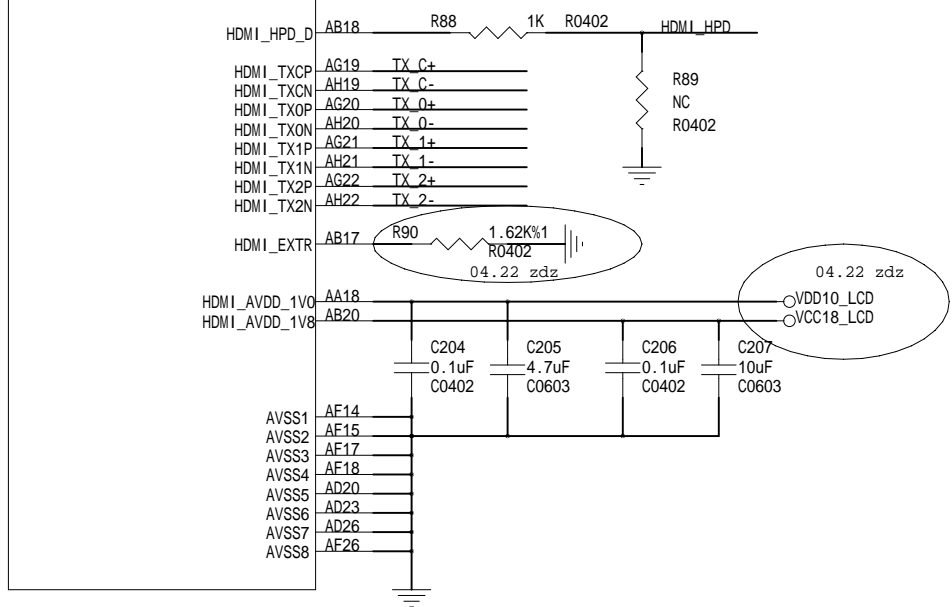

RK3288_O

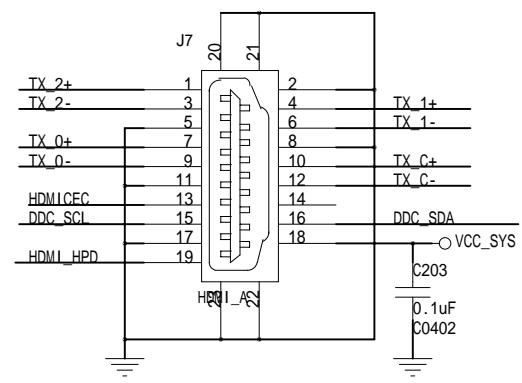
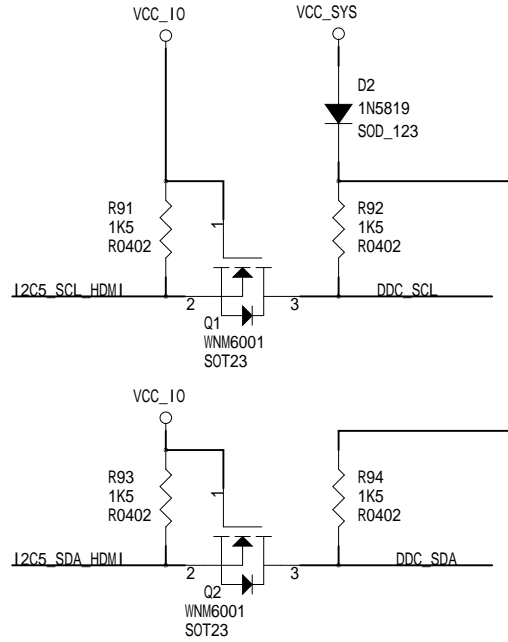
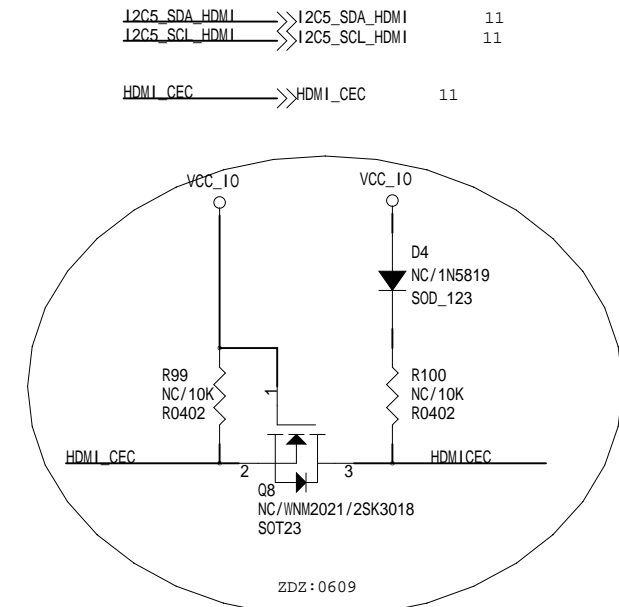

HDMI OUT

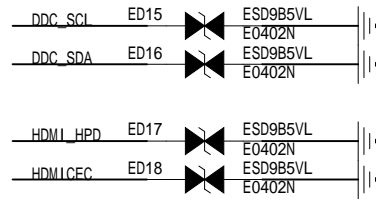
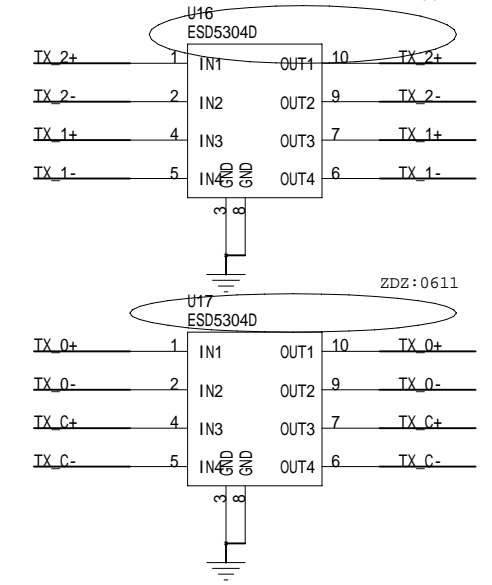

Firefly	
Title: HDMI OUT	
File:	REV: 1.1
Create Date:	Page Numr: 11
Modify Date: Wednesday, June 18, 2014	Page Total: 21

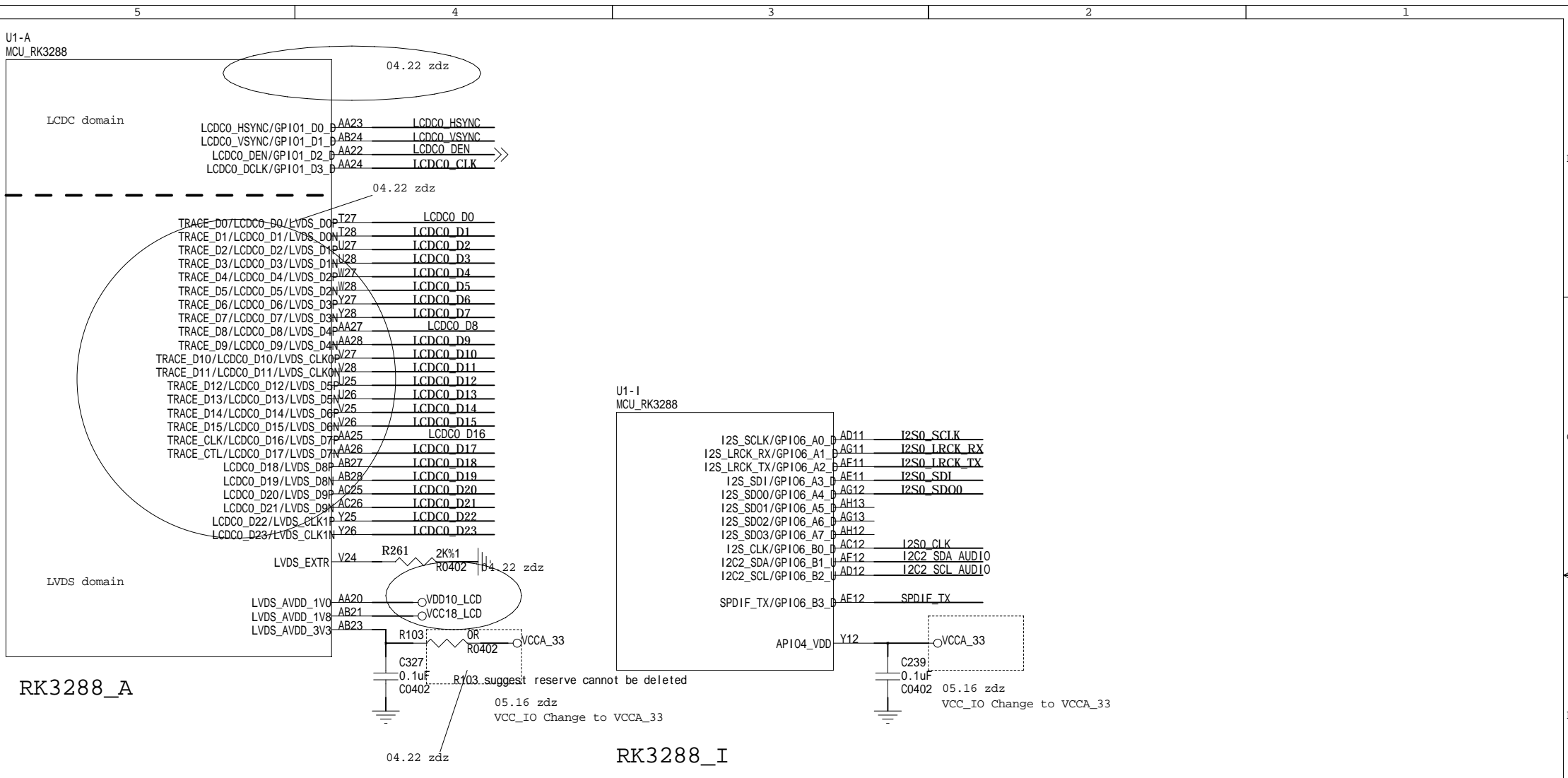

RK3288_A

RK3288_I

Firefly	
Title: RK3288 LCDC/I2S Controller	
File:	REV: 1.1
Create Date:	Page Numr 12
Modify Date: Wednesday, June 18, 2014	Page Total: 21

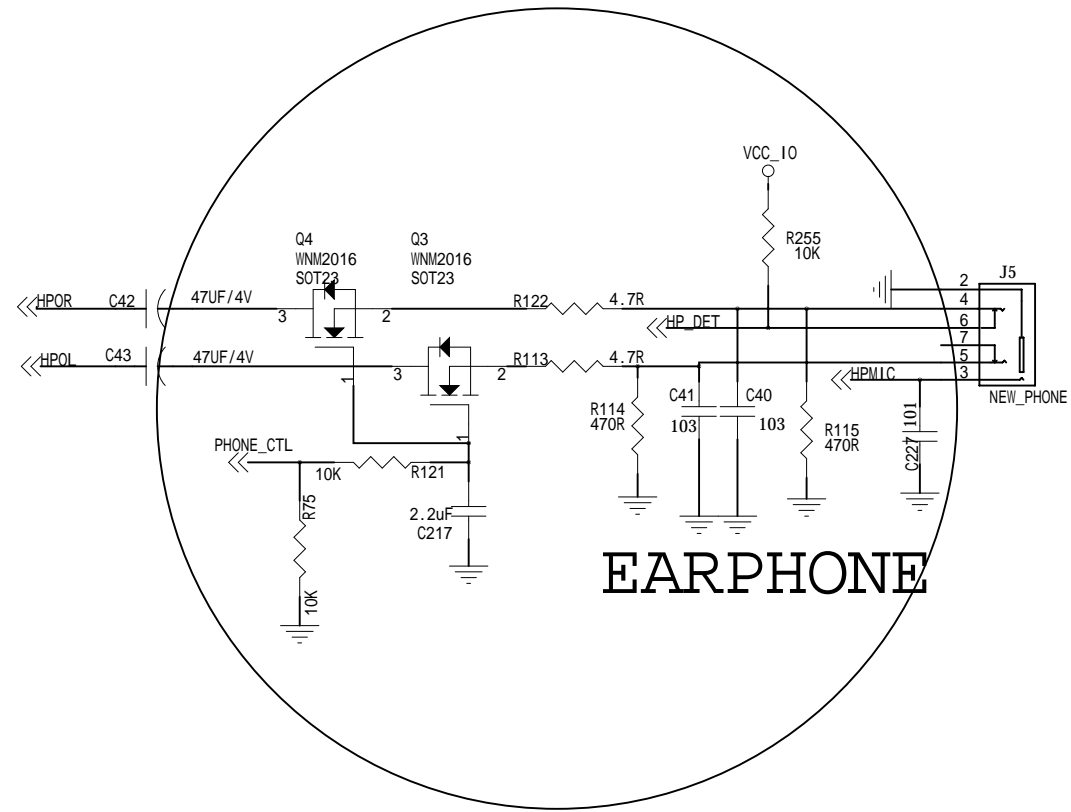
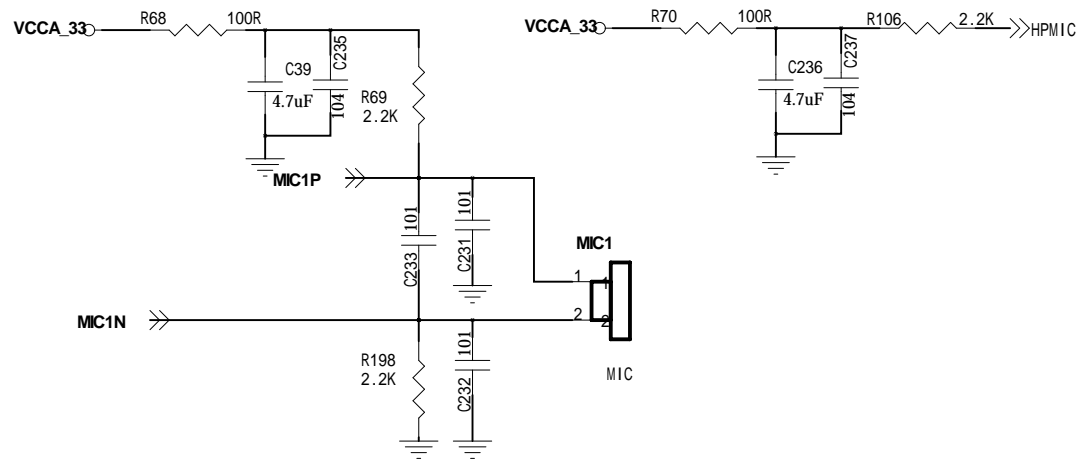
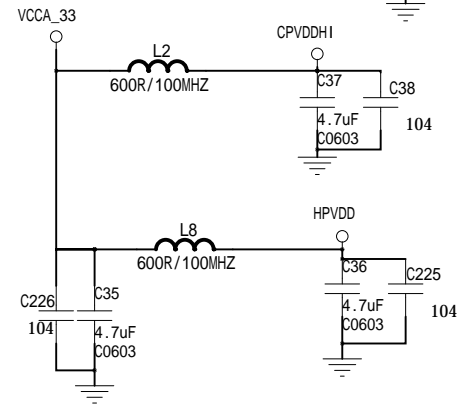
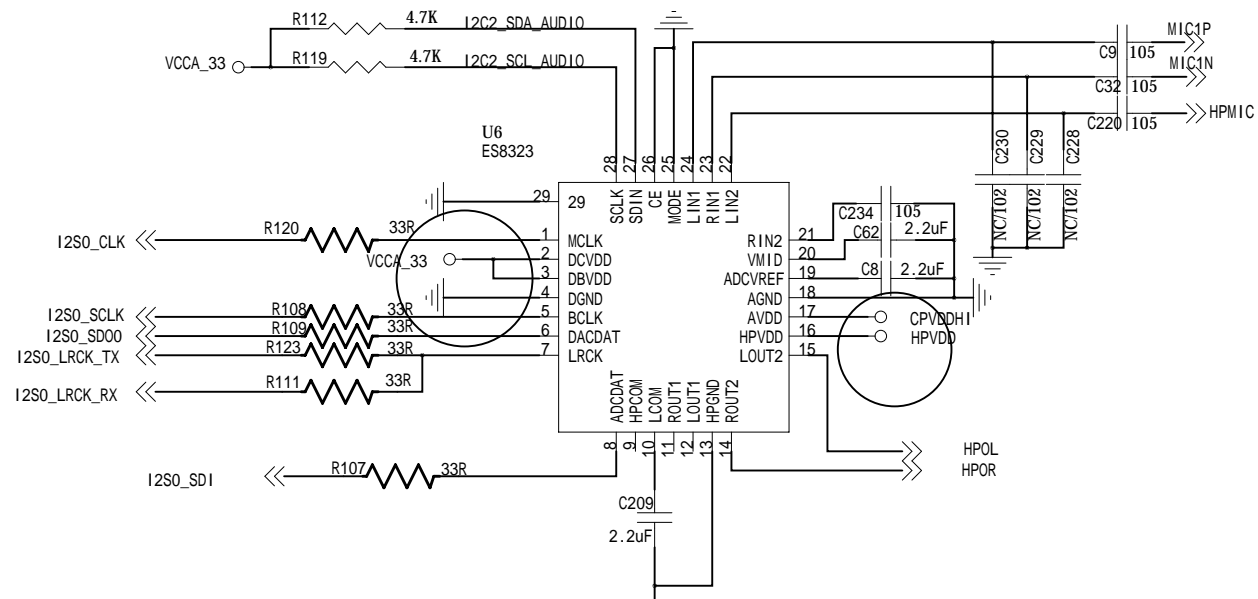

Firefly	
Title: ES8323	
File:	REV: 1.1
Create Date:	Page Num 13
Modify Date: Wednesday, June 18, 2014	Page Total 21

SPDIF_TX >>> SPDIF_TX 13

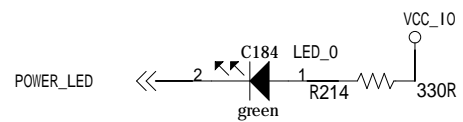
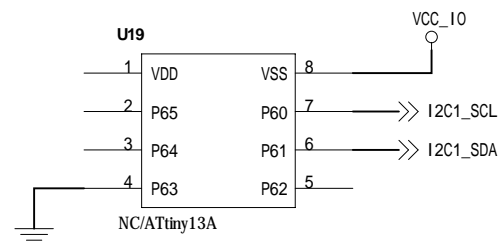
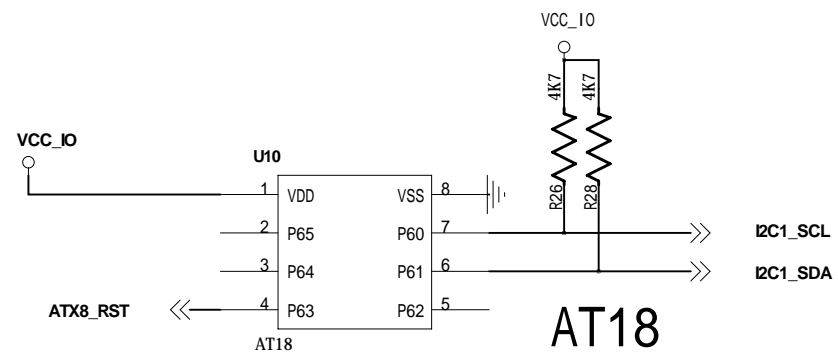
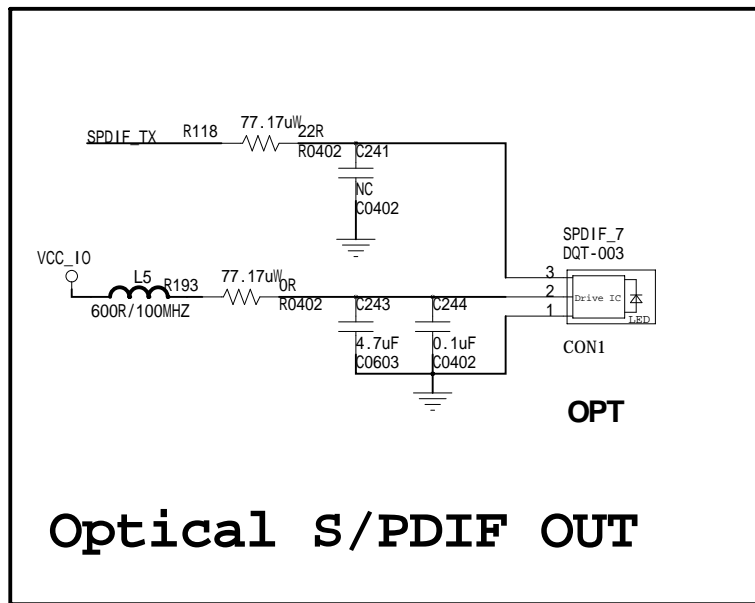

Firefly	
Title: S/PDIF OUT	
File:	REV: 1.1
Create Date:	Page Numr 14
Modify Date: Wednesday, June 18, 2014	Page Total: 21

U1-Q
MCU_RK3288

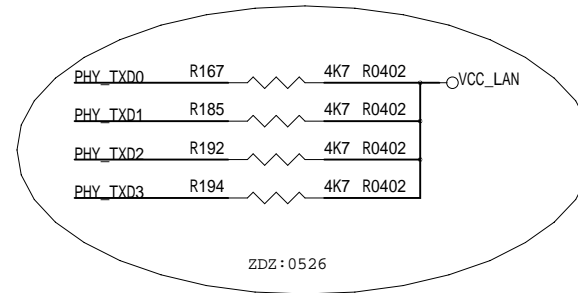
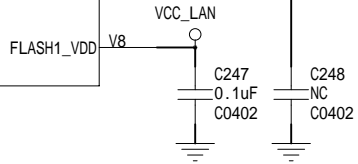
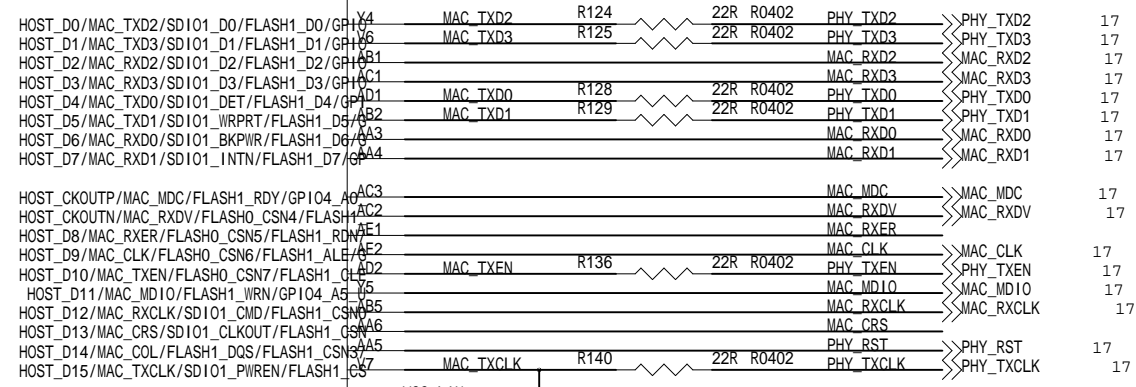

RK3288_Q

Firefly	
Title: RK3288 EthernetMAC Controler	
File:	REV: 1.1
Create Date:	Page Numr 15
Modify Date: Wednesday, June 18, 2014	Page Total: 21

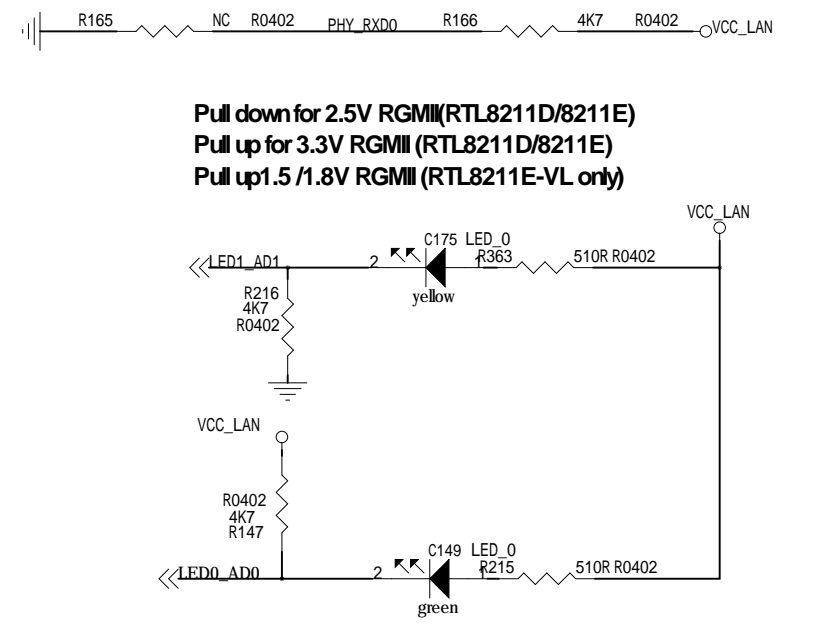
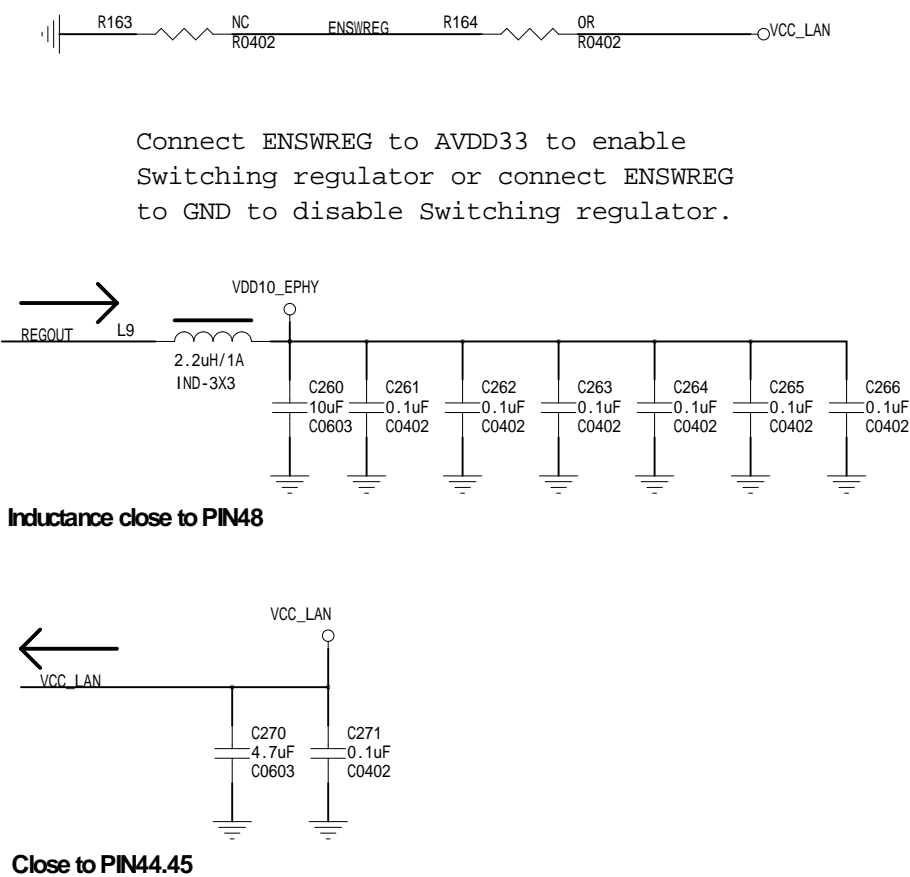
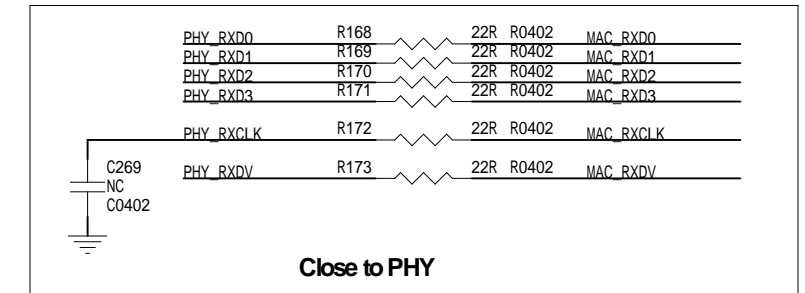
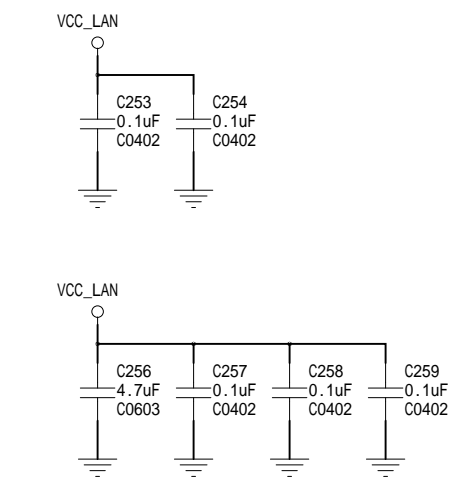
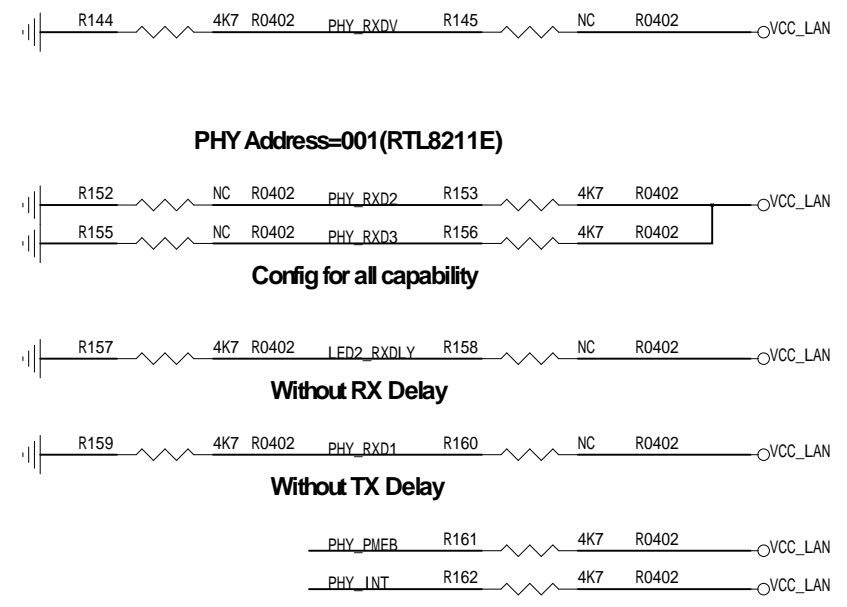
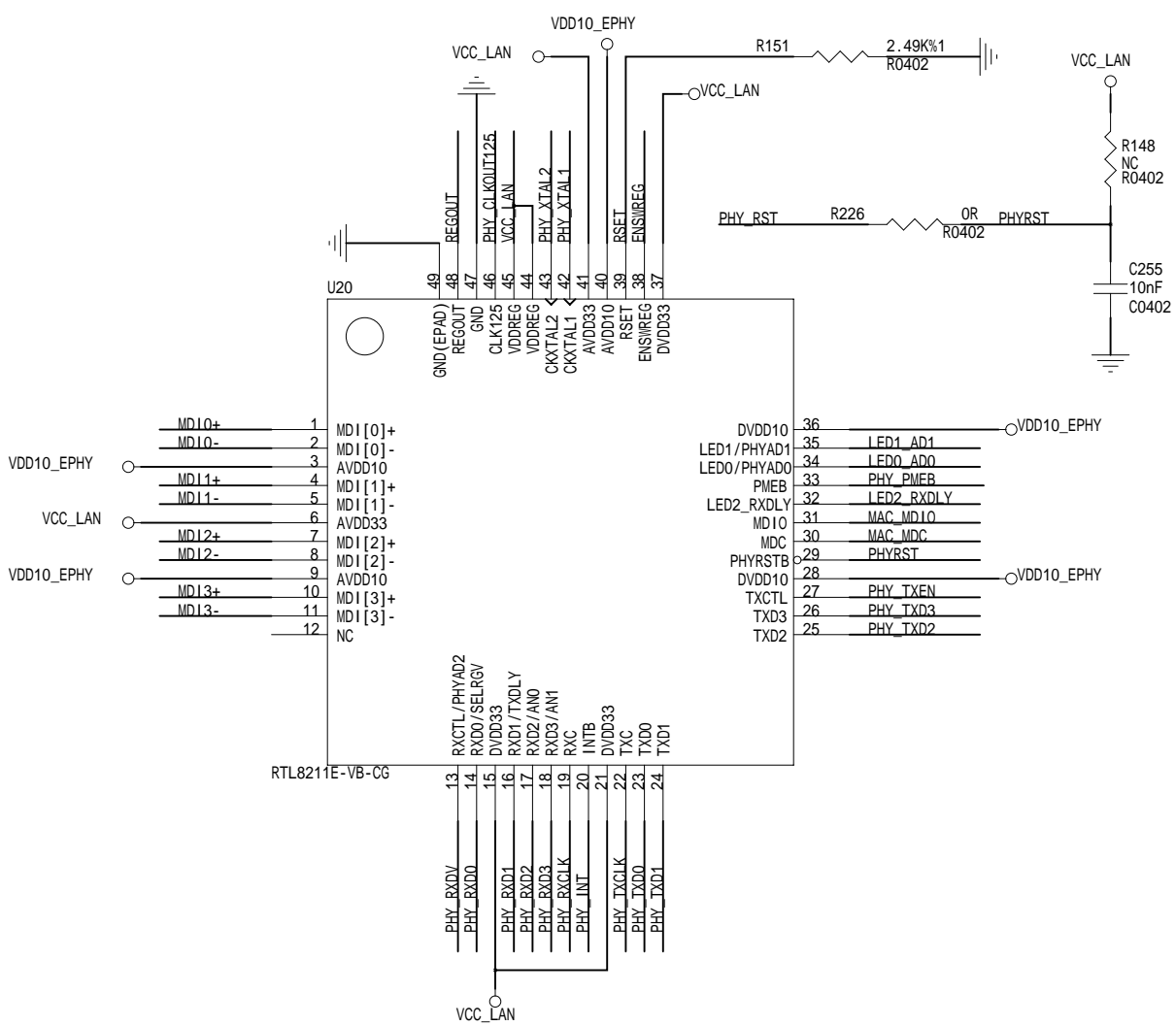
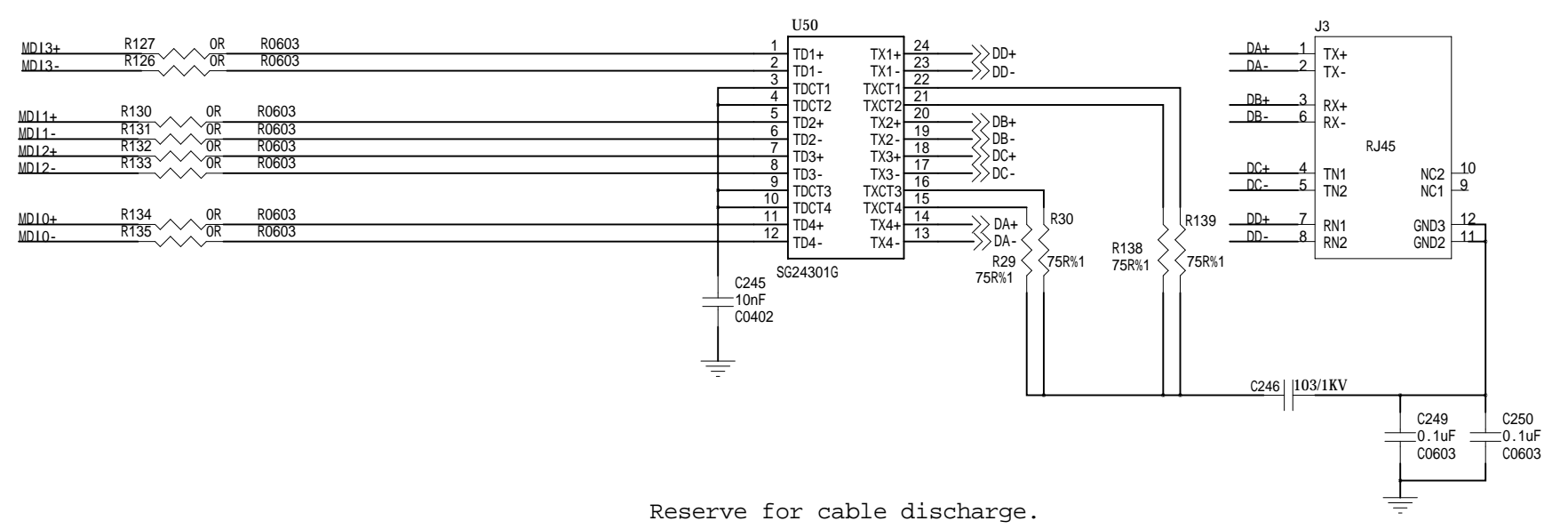
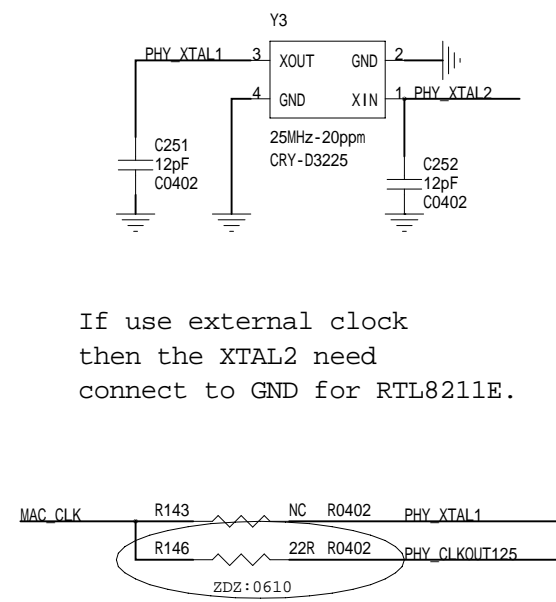
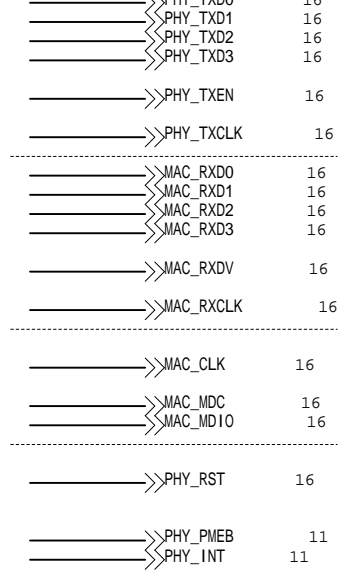

U1-H
MCU_RK3288

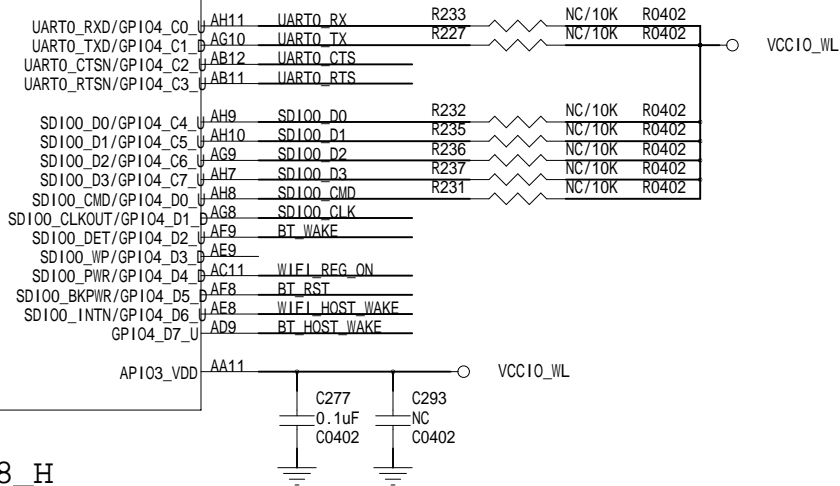

RK3288_H

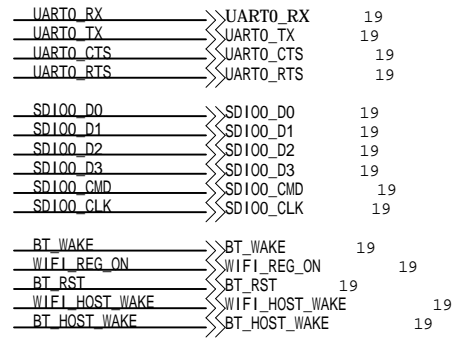

Firefly	
Title: RK3288 SDIO0 Controler	
File:	REV: 1.1
Create Date:	Page Numr: 17
Modify Date: Wednesday, June 18, 2014	Page Total: 21

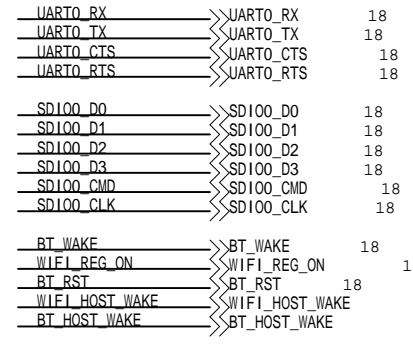

Note:
 Adjusted the load capacitance according to the crystal specification.
 04.22 zdz

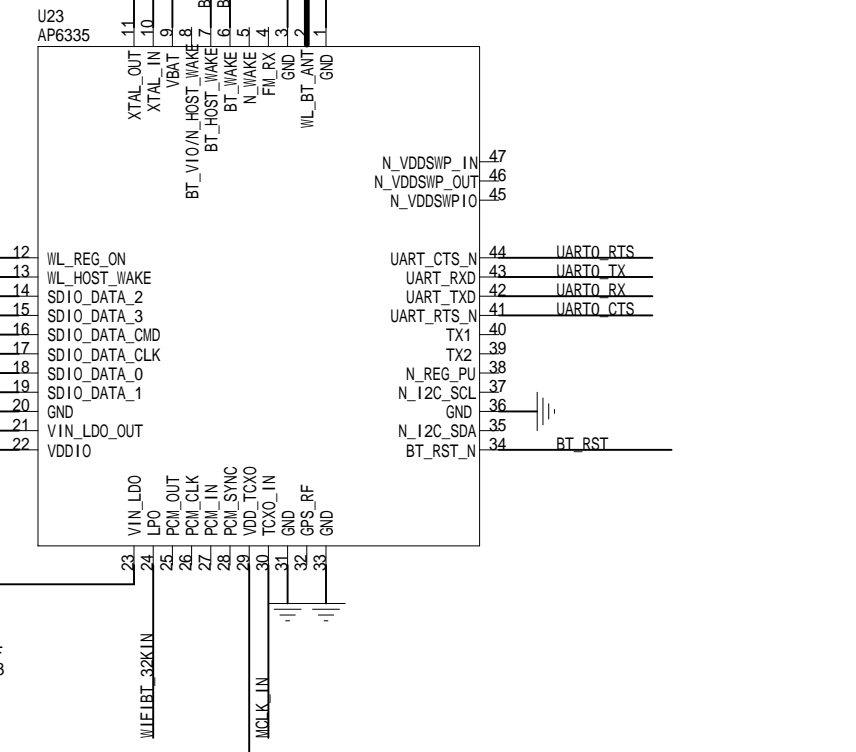
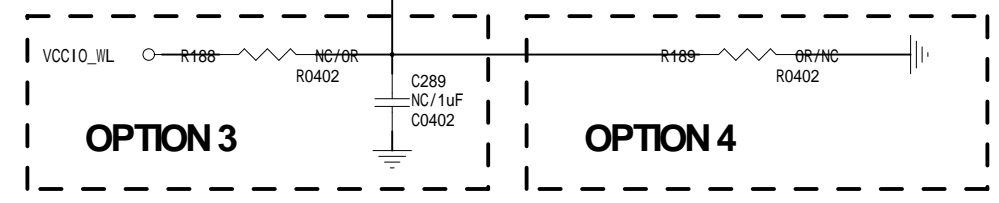
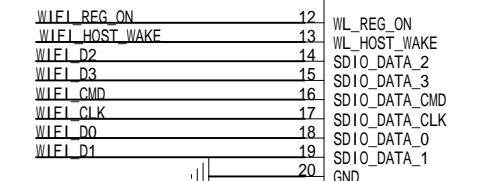
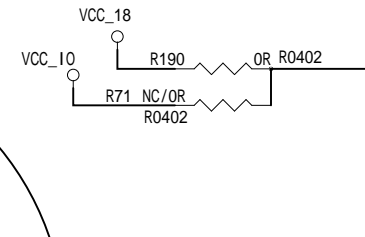
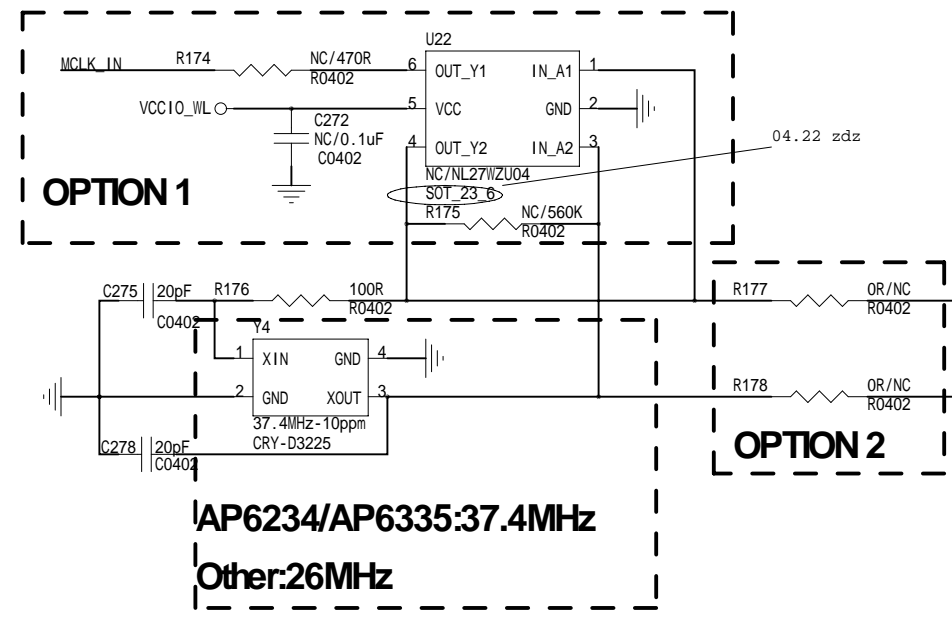
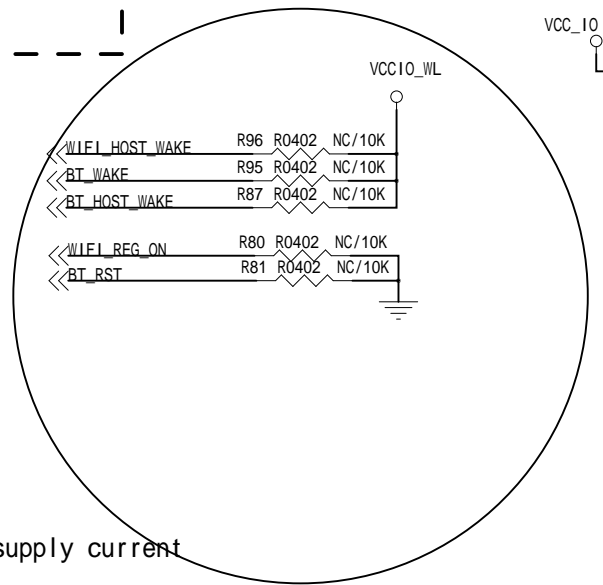
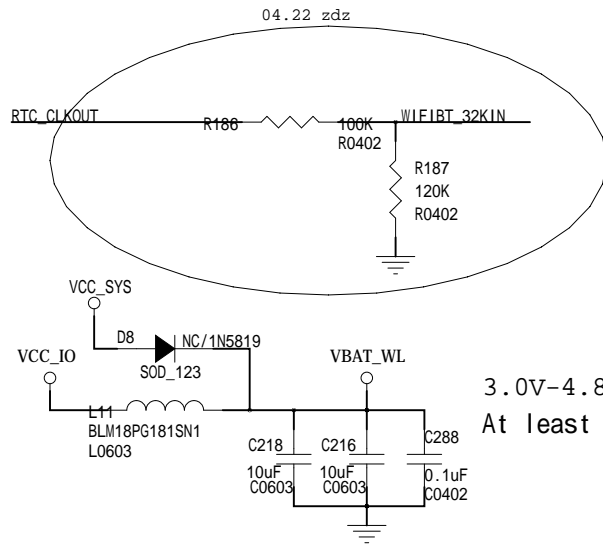
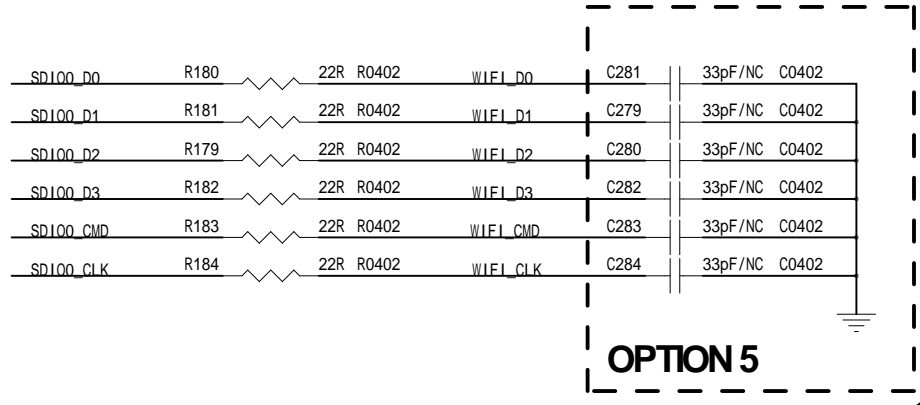

OPTION	WIFI				BT4.0	Crystals	VDDIO
	a	b/g/n	ac	5GHz			
AP6181		Yes				26MHz	1.71-3.6V
AP6210		Yes			Yes	26MHz	1.71-3.6V
AP6234	Yes	Yes		Yes	Yes	37.4MHz	1.6-3.4V
AP6330	Yes	Yes		Yes	Yes	26MHz	1.2-2.9V
AP6335 (Default)	Yes	Yes	Yes	Yes	Yes	37.4MHz	1.71-3.63V

OPTION	1	2	3	4	5
AP6181	No	Yes	No	No	No
AP6210	Yes	No	Yes	No	No
AP6234	No	Yes	No	No	No
AP6330	No	Yes	No	No	No
AP6335 (Default)	No	Yes	No	Yes	Yes

Note:
 Yes: Inside the box to
 No: The box is not posted

Firefly	
Title: AP6XXX-WIFI/BT	
File:	REV: 1.1
Create Date:	Page Num 18
Modify Date: Wednesday, June 18, 2014	Page Total 21

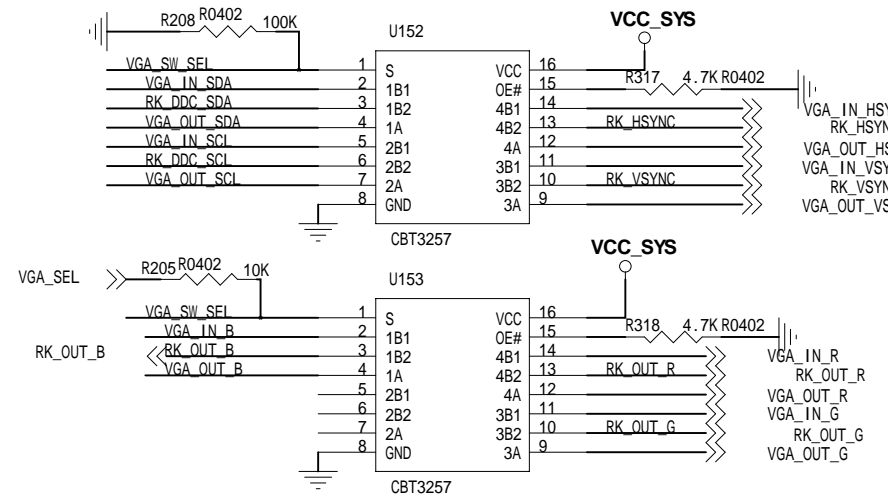
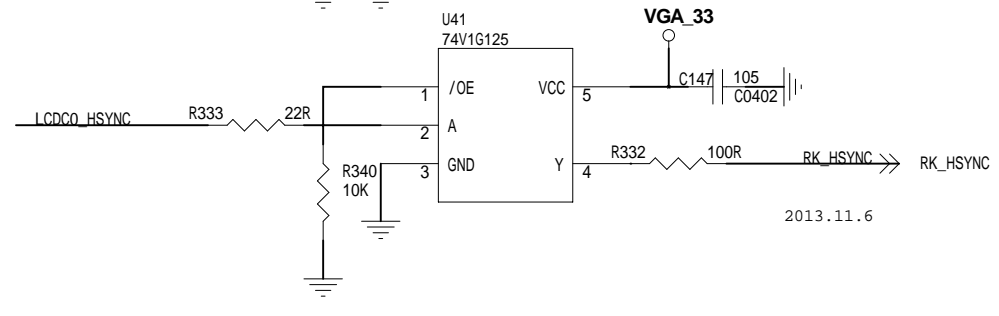
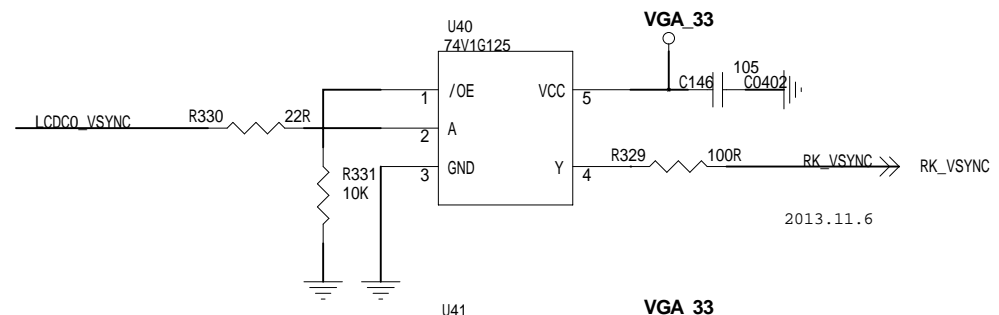
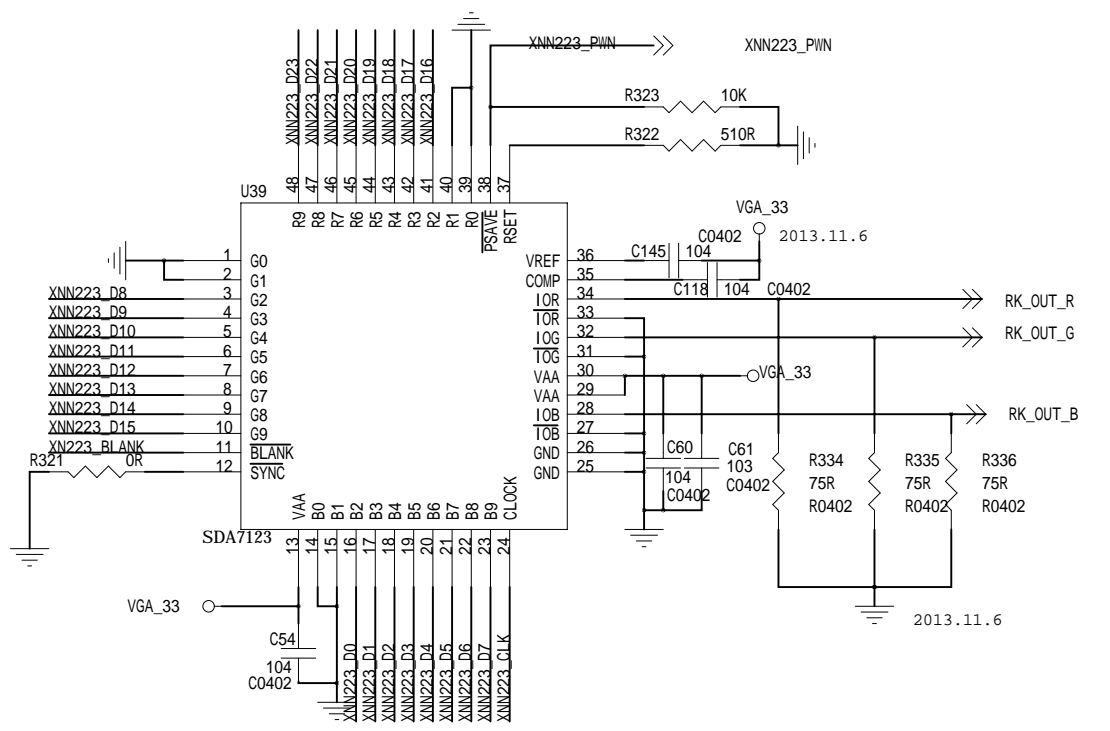
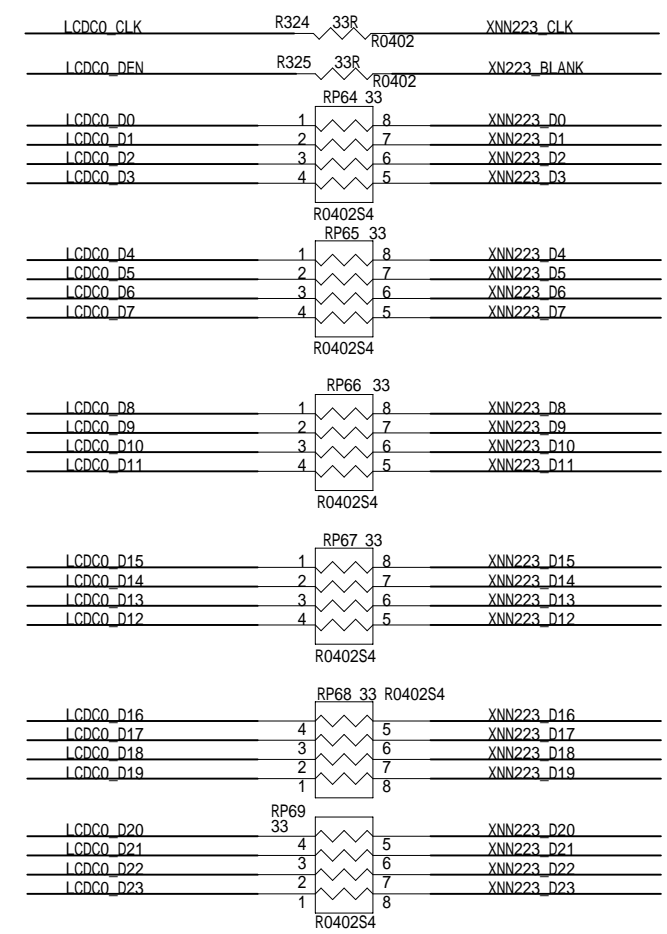
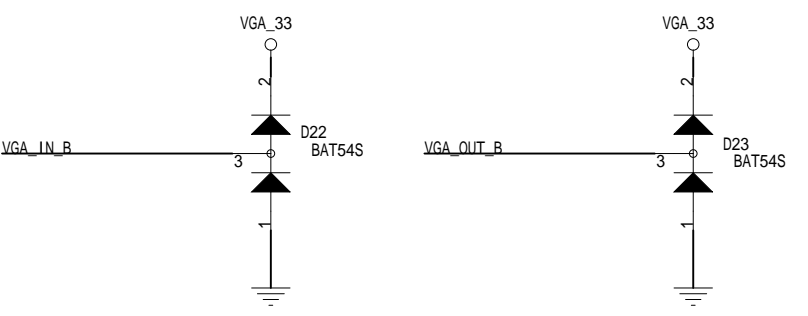
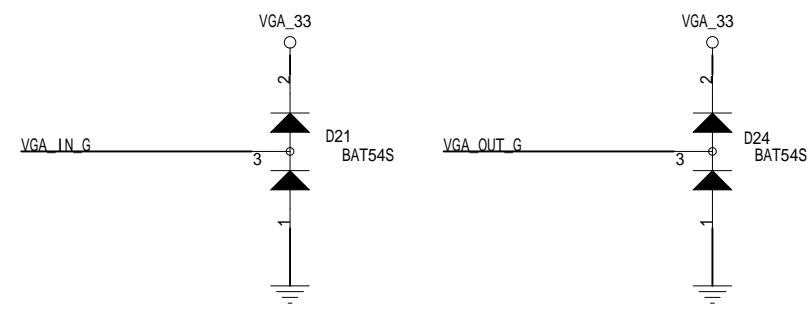
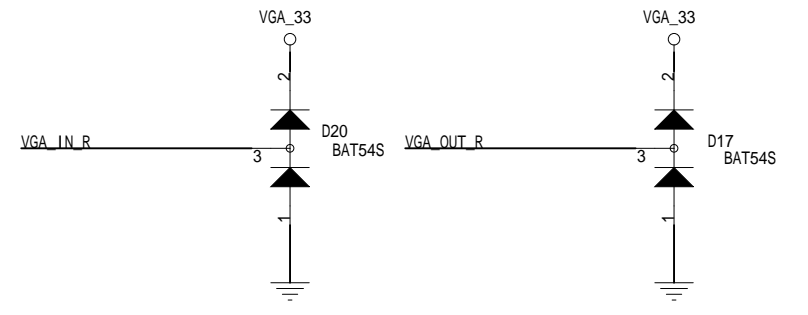
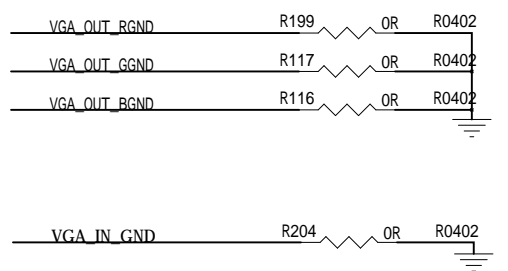
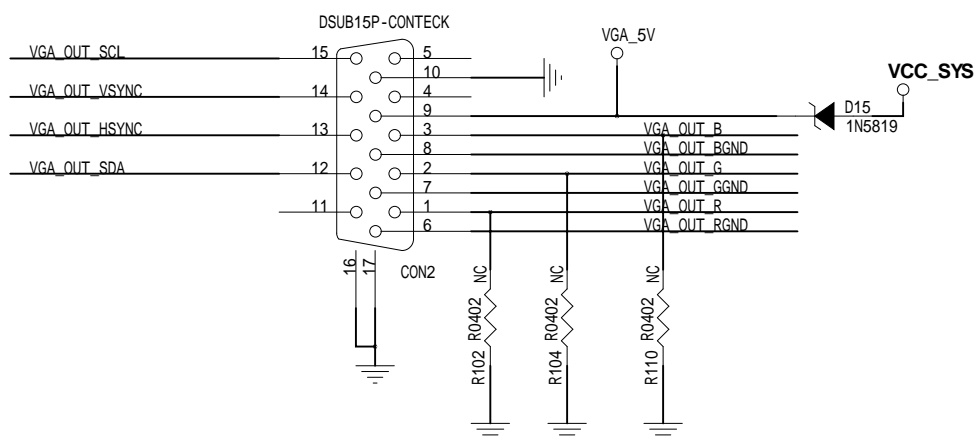

VGA_SEL	Function
High	VGA_OUT=RK_OUT
Low(Default)	VGA_OUT=VGA_IN

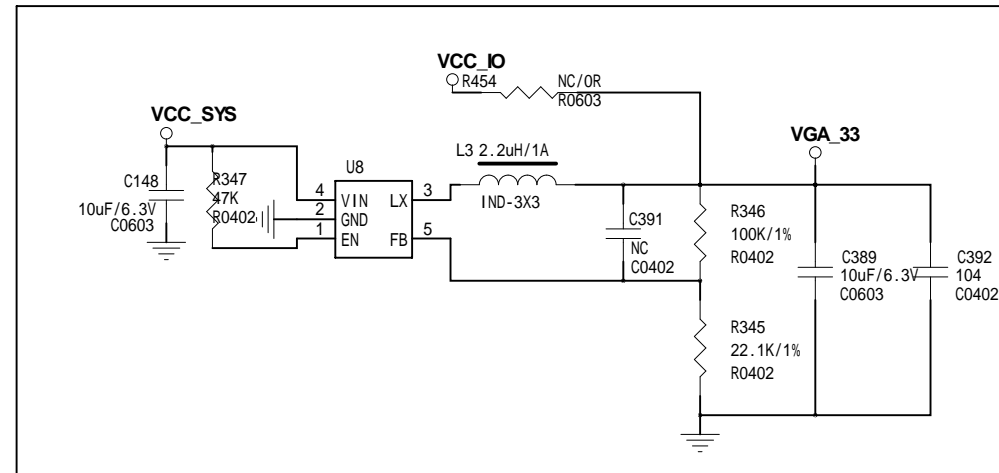
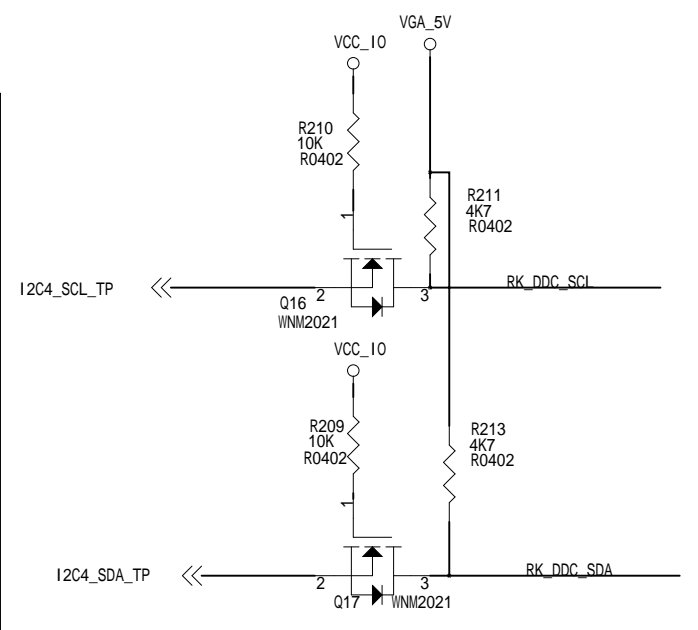

Firefly	
Title:	
File:	
REV: 1.1	
Create Date:	Page Num: 19
Modify Date: Wednesday, June 18, 2014	Page Total: 21

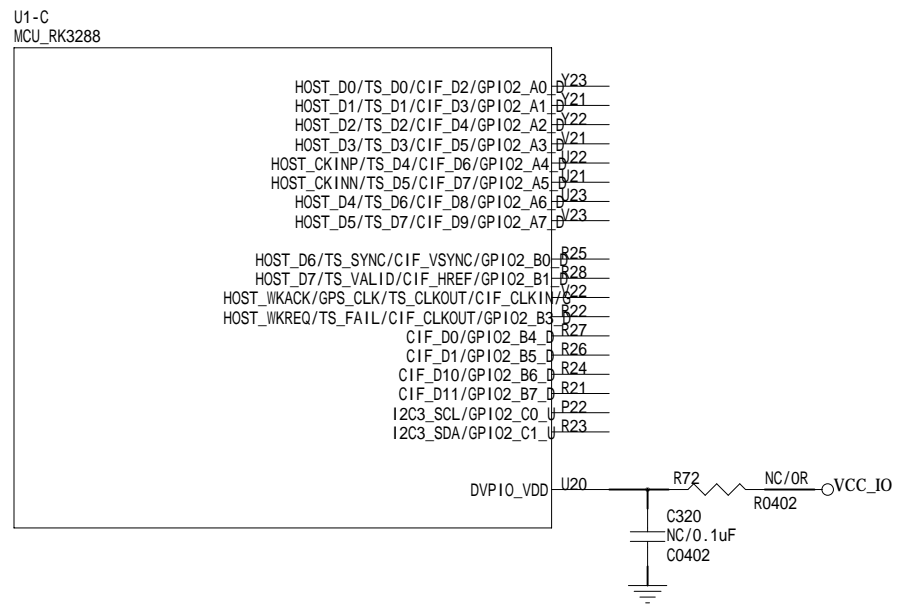

RK3288_C

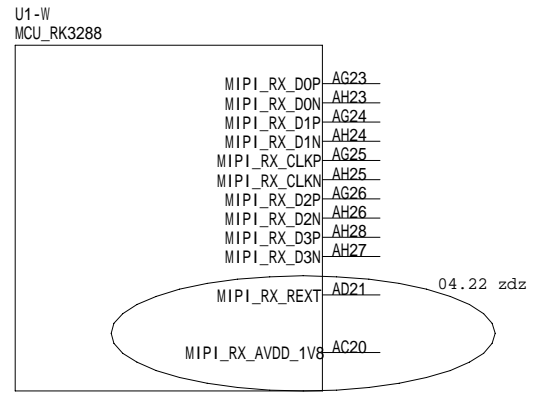
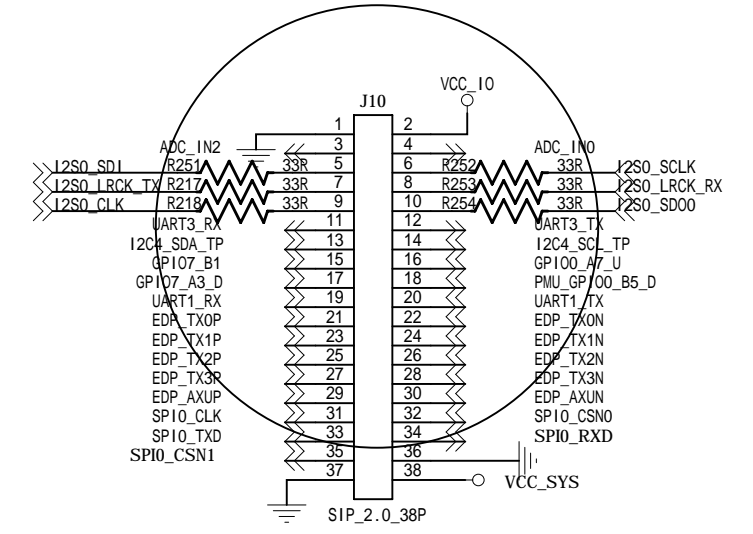
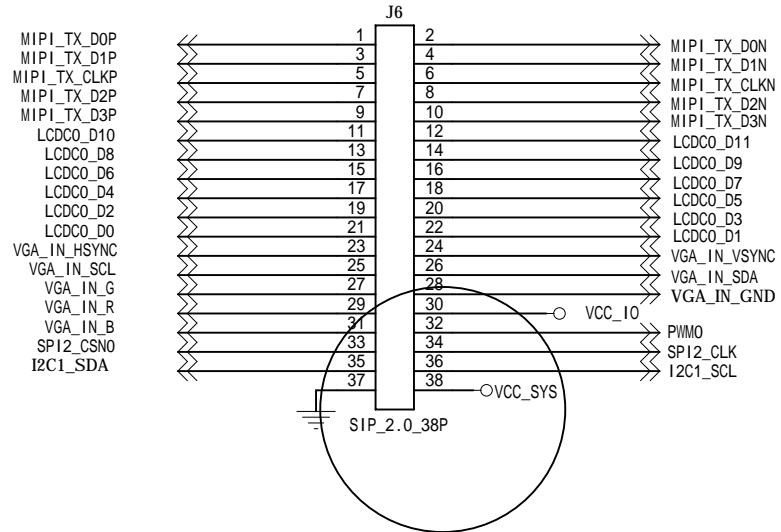

RK3288_W

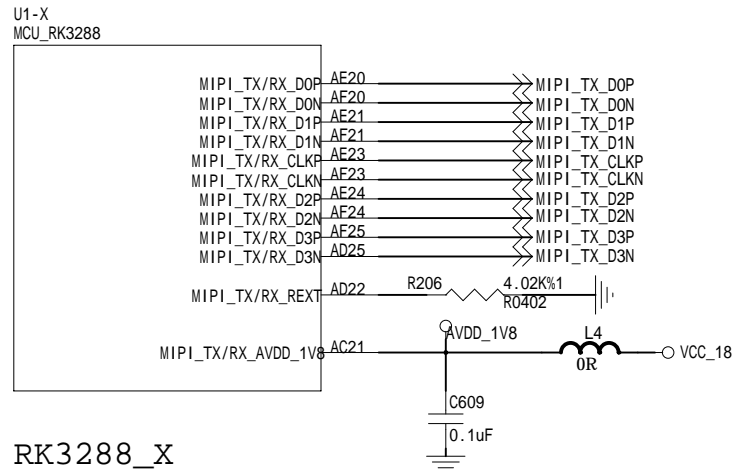

RK3288_X

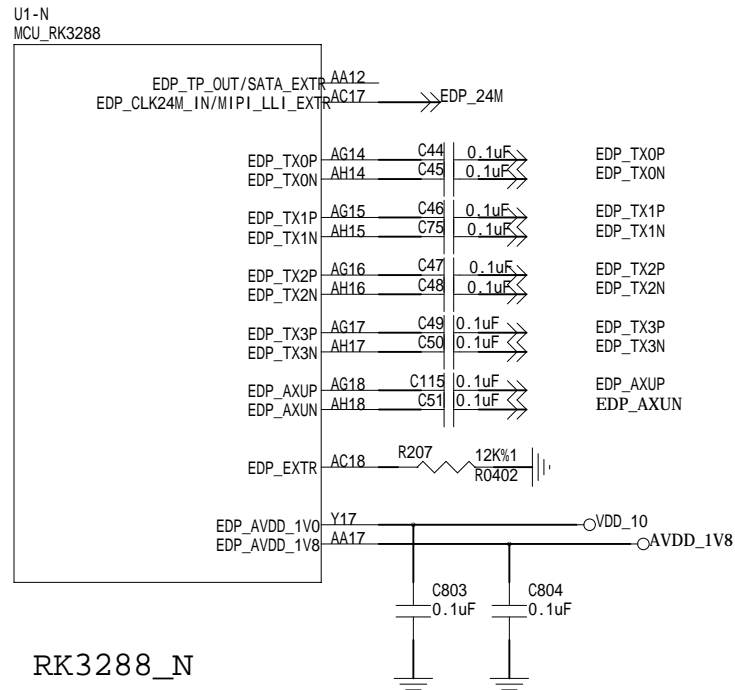

RK3288_N

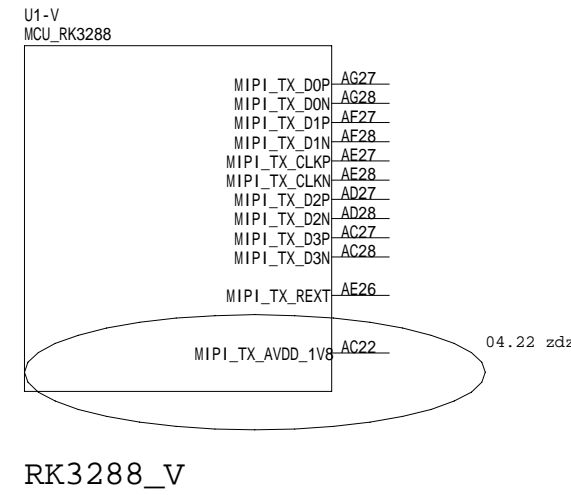
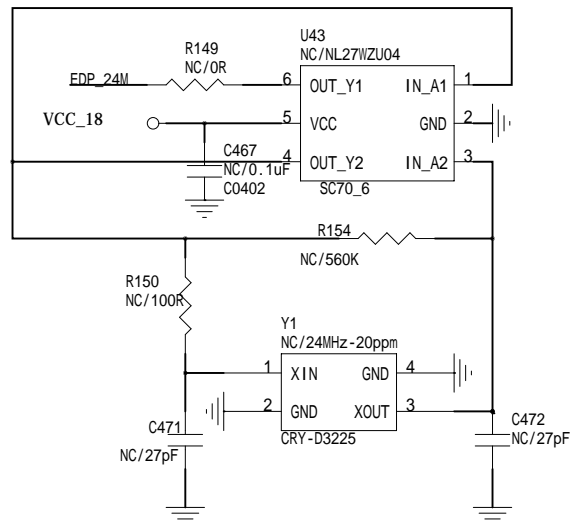

RK3288_V

Firefly	
Title: Camera Interface	
File:	REV: 1.1
Create Date:	Page Num: 20
Modify Date: Wednesday, June 18, 2014	Page Total: 21

U1-J
MCU_RK3288

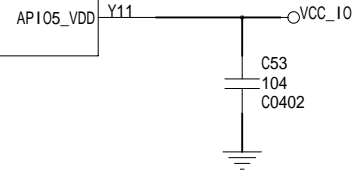
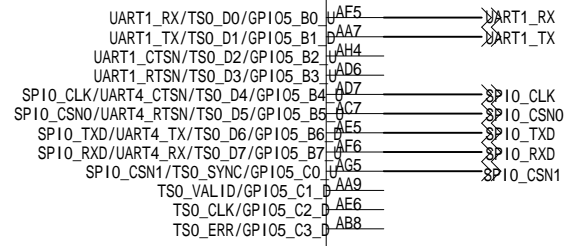

RK3288_J

Firefly	
Title: DTV-(Reserve)	
File:	REV: 1.1
Create Date:	Page Numr: 21
Modify Date: Wednesday, June 18, 2014	Page Total: 21