

Rockchip RK1108 Datasheet

**Revision 0.4
July. 2016**

Revision History

Date	Revision	Description
2016-7-7	0.4	Update
2016-7-6	0.3	Update
2016-7-5	0.2	Update
2016-6-2	0.1	Initial Release

Rockchip Confidential

Table of Content

Table of Content	3
Figure Index	4
Table Index.....	5
Warranty Disclaimer.....	6
Chapter 1 Introduction	7
1.1 Features	7
1.2 Block Diagram	17
Chapter 2 Package Information.....	19
2.1 Ordering information	19
2.2 Top Marking	19
2.3 Dimension.....	20
2.4 Ball Map	22
2.5 Ball Pin Number Order	27
2.6 RK1108 Power/ground IO descriptions.....	36
2.7 RK1108 Function IO description	39
2.8 IO Pin Name Description	52
2.9 RK1108 IO Type.....	57
Chapter 3 Electrical Specification	58
3.1 Absolute Maximum Ratings.....	58
3.2 Recommended Operating Condition	58
3.3 DC Characteristics.....	60
3.4 Recommended Operating Frequency	62
3.5 Electrical Characteristics for General IO	66
3.6 Electrical Characteristics for PLL	66
3.7 Electrical Characteristics for USB Interface.....	67
3.8 Electrical Characteristics for DDR IO.....	68
3.9 Electrical Characteristics for eFuse	68
3.10 Electrical Characteristics for HDMI.....	68
3.11 Electrical Characteristics for VDAC	68
3.12 Electrical Characteristics for TSADC.....	69
3.13 Electrical Characteristics for MIPI DSI.....	69
3.14 Electrical Characteristics for MIPI CSI	70
3.15 Electrical Characteristics for SARADC.....	70
3.16 Electrical Characteristics for ACODEC	71
3.17 Electrical Characteristics for VIDEO ADC	71

Figure Index

Fig. 1-1 RK1108 Block Diagram	18
Fig. 2-1 RK1108 BGA359 Package Top View and bottom view.....	21
Fig. 2-2 RK1108 BGA359 Package Side View	22
Fig. 2-3 RK1108 BGA359 Package Dimension	22
Fig. 2-4 RK1108A BGA 359 Ball Map.....	26
Fig. 2-5 RK1108B BGA 359 Ball Map.....	27

Rockchip Confidential

Table Index

Table 2-1 RK1108A BGA359 Pin Number Order Information	27
Table 2-2 RK1108B BGA359 Pin Number Order Information	31
Table 2-3 RK1108A Power/Ground IO information.....	36
Table 2-4 RK1108B Power/Ground IO information.....	37
Table 2-5 RK1108A function IO description.....	40
Table 2-6 RK1108B function IO description.....	46
Table 2-7 RK1108 IO Type List.....	57
Table 3-1 RK1108 absolute maximum ratings	58
Table 3-2 RK1108 recommended operating condition	58
Table 3-3 RK1108 DC Characteristics	60
Table 3-4 Recommended operating frequency for bus domain	62
Table 3-5 Recommended operating frequency for CORE.....	63
Table 3-6 Recommended operating frequency for DSP.....	63
Table 3-7 Recommended operating frequency for PERI domain.....	63
Table 3-8 Recommended operating frequency for RKVENC domain.....	64
Table 3-9 Recommended operating frequency for RKVDEC domain.....	64
Table 3-10 Recommended operating frequency for VIO	65
Table 3-11 RK1108 Electrical Characteristics for Digital General IO	66
Table 3-12 RK1108 Electrical Characteristics for PLL	66
Table 3-13 RK1108 Electrical Characteristics for DDR IO.....	68
Table 3-14 RK1108 Electrical Characteristics for eFuse	68
Table 3-15 RK1108 Electrical Characteristics for HDMI	68
Table 3-16 RK1108 Electrical Characteristics for VDAC	68
Table 3-17 RK1108 Electrical Characteristics for TSADC.....	69
Table 3-18 RK1108 Electrical Characteristics for MIPI DSI.....	69
Table 3-19 RK1108 Electrical Characteristics for MIPI CSI.....	70
Table 3-20 RK1108 Electrical Characteristics for SARADC.....	70
Table 3-21 RK1108 Electrical Characteristics for ACODEC	71
Table 3-22 RK1108 Electrical Characteristics for VIDEO ADC	71

Warranty Disclaimer

Rockchip Electronics Co.,Ltd makes no warranty, representation or guarantee (expressed, implied, statutory, or otherwise) by or with respect to anything in this document, and shall not be liable for any implied warranties of non-infringement, merchantability or fitness for a particular purpose or for any indirect, special or consequential damages.

Information furnished is believed to be accurate and reliable. However, Rockchip Electronics Co.,Ltd assumes no responsibility for the consequences of use of such information or for any infringement of patents or other rights of third parties that may result from its use.

Rockchip Electronics Co.,Ltd's products are not designed, intended, or authorized for using as components in systems intended for surgical implant into the body, or other applications intended to support or sustain life, or for any other application in which the failure of the Rockchip Electronics Co.,Ltd's product could create a situation where personal injury or death may occur, should buyer purchase or use Rockchip Electronics Co.,Ltd's products for any such unintended or unauthorized application, buyers shall indemnify and hold Rockchip Electronics Co.,Ltd and its officers, employees, subsidiaries, affiliates, and distributors harmless against all claims, costs, damages, expenses, and reasonable attorney fees arising out of, either directly or indirectly, any claim of personal injury or death that may be associated with such unintended or unauthorized use, even if such claim alleges that Rockchip Electronics Co.,Ltd was negligent regarding the design or manufacture of the part.

Copyright and Patent Right

Information in this document is provided solely to enable system and software implementers to use Rockchip Electronics Co.,Ltd's products. There are no expressed or implied copyright licenses granted hereunder to design or fabricate any integrated circuits or integrated circuits based on the information in this document.

Rockchip Electronics Co.,Ltd does not convey any license under its patent rights nor the rights of others.

All copyright and patent rights referenced in this document belong to their respective owners and shall be subject to corresponding copyright and patent licensing requirements.

Trademarks

Rockchip and Rockchip™ logo and the name of Rockchip Electronics Co.,Ltd's products are trademarks of Rockchip Electronics Co.,Ltd. and are exclusively owned by Rockchip Electronics Co.,Ltd. References to other companies and their products use trademarks owned by the respective companies and are for reference purpose only.

Confidentiality

The information contained herein (including any attachments) is confidential. The recipient hereby acknowledges the confidentiality of this document, and except for the specific purpose, this document shall not be disclosed to any third party.

Reverse engineering or disassembly is prohibited.

ROCKCHIP ELECTRONICS CO.,LTD. RESERVES THE RIGHT TO MAKE CHANGES IN ITS PRODUCTS OR PRODUCT SPECIFICATIONS WITH THE INTENT TO IMPROVE FUNCTION OR DESIGN AT ANY TIME AND WITHOUT NOTICE AND IS NOT REQUIRED TO UNDATE THIS DOCUMENTATION TO REFLECT SUCH CHANGES.

Copyright © 2016 Rockchip Electronics Co., Ltd.

All rights reserved. No part of this publication may be reproduced, stored in a retrieval system, or transmitted in any form or by any means, electric or mechanical, by photocopying, recording, or otherwise, without the prior written consent of Rockchip Electronics Co.,Ltd.

Chapter 1 Introduction

RK1108 is a high performance low power application processor. It is embedded with a new generation DSP for digital process and an ARM Cortex-A7 single core processor for system and application. Especially, it is a high-integration and cost efficient SoC which can support H.264 video encoder/decoder up to 1440p, up to 4 camera inputs simultaneously, merge different camera sources together and display on one screen.

It is designed for varies application scenario such as car DVR, sports DV, secure camera and UAV camera.

RK1108 support lots of camera interface such as MIPI-CSI, CVBS in and 12-bit parallel raw and it also support lots of display interface such as MIPI-DSI, HDMI 1.4, CVBS out and serial/parallel RGB.

RK1108B package with 16bit DDR3 chip to meet a high-performance up to 1600M and make cost lower.

1.1 Features

The features listed below which may or may not be present in actual product, may be subject to the third party licensing requirements. Please contact Rockchip for actual product feature configurations and licensing requirements.

1.1.1 Microprocessor

- Single-core ARM Cortex-A7 Core processor, a high-performance, low-power and cached application processor
- Full implementation of the ARM architecture v7-A instruction set, ARM Neon Advanced SIMD (single instruction, multiple data) support for accelerated media and signal processing computation
- Separately integrated NEON and FPU
- 32KB/32KB L1 I-Cache/D-Cache
- Unified 128KB L2 Cache.
- Trustzone technology support

1.1.2 Video/Image Digital Signal Processor

- 32KB I-TCM and 32KB I-cache
- 128KB D-TCM
- Max operation frequency up to 600MHz

1.1.3 Memory Organization

- Internal on-chip memory
 - BootRom
 - Internal SRAM
- External off-chip memory^①
 - DDR3/DDR3L
 - Async Nand Flash

1.1.4 Internal Memory

- Internal BootRom
 - Size : 10KB
 - Support system boot from the following device :
 - ◆ 8bits Async Nand Flash
 - ◆ SPI interface
 - ◆ eMMC interface
 - ◆ SDMMC interface
 - Support system code download by the following interface:

- ◆ USB OTG interface
- Internal SRAM
 - Size : 12KB

1.1.5 External Memory or Storage device

- Dynamic Memory Interface (DDR3/DDR3L)
 - Compatible with JEDEC standard DDR3-1600/DDR3L-1600 SDRAM
 - Supports 16 Bits data width, 1 ranks (chip selects), totally 512MB (max) address space.
 - Programmable timing parameters to support DDR3/DDR3L SDRAM from various vendor
 - Advanced command reordering and scheduling to maximize bus utilization
 - Low power modes, such as power-down and self-refresh for DDR3 SDRAM; Compensation for board delays and variable latencies through programmable pipelines
 - Programmable output and ODT impedance with dynamic PVT compensation
- Nand Flash Interface
 - Support 8bits async nandflash
 - 16bits hardware ECC
 - For async nandflash, support configurable interface timing, maximum data rate is 8bit/cycle
 - Embedded AHB master interface to do data transfer by DMA method
- eMMC Interface
 - Compatible with standard iNAND interface
 - Support MMC4.51 protocol
 - Provide eMMC boot sequence to receive boot data from external eMMC device
 - Support FIFO over-run and under-run prevention by stopping card clock automatically
 - Support CRC generation and error detection
 - Embedded clock frequency division control to provide programmable baud rate
 - Support block size from 1 to 65535Bytes
 - 8bits data bus width
- SD/MMC Interface
 - Compatible with SD3.0, MMC ver4.51
 - Support FIFO over-run and under-run prevention by stopping card clock automatically
 - Support CRC generation and error detection
 - Support block size from 1 to 65535Bytes
 - Data bus width is 4bits

1.1.6 System Component

- CRU (clock & reset unit)
 - Support clock gating control for individual components inside RK1108
 - One oscillator with 24MHz clock input and 3 embedded PLLs
 - Support global soft-reset control for whole SOC, also individual soft-reset for every components
- Timer
 - 2 on-chip 64bits Timers in SoC with interrupt-based operation
 - Provide two operation modes: free-running and user-defined count
 - Support timer work state checkable
 - Fixed 24MHz clock input
- PWM
 - Eight on-chip PWMs with interrupt-based operation

- Programmable pre-scaled operation to bus clock and then further scaled
- Embedded 32-bit timer/counter facility
- Support capture mode
- Support continuous mode or one-shot mode
- Provides reference mode and output various duty-cycle waveform
- WatchDog
 - 32 bits watchdog counter width
 - Counter clock is from APB bus clock
 - Counter counts down from a preset value to 0 to indicate the occurrence of a timeout
 - WDT can perform two types of operations when timeout occurs:
 - ◆ Generate a system reset
 - ◆ First generate an interrupt and if this is not cleared by the service routine by the time a second timeout occurs then generate a system reset
 - Programmable reset pulse length
 - Totally 16 defined-ranges of main timeout period
- Bus Architecture
 - 128bit/64-bit/32-bit multi-layer AXI/AHB/APB composite bus architecture
 - 5 embedded AXI interconnect
 - ◆ CPU interconnect with one 128-bits AXI masters, one APB slaves
 - ◆ DSP interconnect with two 128-bits AXI masters, one 128-bits AXI slave, one 32-bits APB master and many 32-bits APB slaves
 - ◆ PERI interconnect with eight 32-bits AHB masters and lots of 32-bits AHB/APB slaves
 - ◆ Display interconnect with two 128-bits AXI master, seven 64-bits AXI masters and lots 32-bits AHB/APB slave
 - ◆ VENC interconnect with two 128-bits AXI masters, and one 32-bits AHB slaves
 - ◆ VDEC interconnect also with two 64-bits AXI master and two 32-bits AHB slaves
 - Flexible different QoS solution to improve the utility of bus bandwidth
- Interrupt Controller
 - Support 3 PPI interrupt source and 128 SPI interrupt sources input from different components inside RK1108
 - Support 16 software-triggered interrupts
 - Input interrupt level is fixed , only high-level sensitive
 - Two interrupt outputs (nFIQ and nIRQ)separately for each Cortex-A7, both are low-level sensitive
 - Support different interrupt priority for each interrupt source, and they are always software-programmable
 - One non-maskable interrupt for DSP
 - Four hardware maskable interrupts for DSP
 - Four software maskable interrupts
- DMAC
 - Micro-code programming based DMA
 - The specific instruction set provides flexibility for programming DMA transfers
 - Linked list DMA function is supported to complete scatter-gather transfer
 - Support internal instruction cache
 - Embedded DMA manager thread
 - Support data transfer types with memory-to-memory, memory-to-peripheral, peripheral-to-memory
 - Signals the occurrence of various DMA events using the interrupt output signals
 - Mapping relationship between each channel and different interrupt outputs is software-programmable
 - One embedded DMA controller for system
 - DMAC features:

- ◆ 8 channels totally
 - ◆ 16 hardware request from peripherals
 - ◆ 2 interrupt output
 - ◆ Dual APB slave interface for register configuration, designated as secure and non-secure
 - ◆ Support trustzone technology and programmable secure state for each DMA channel
- Security system
 - Embedded encryption and decryption engine
 - ◆ Support AES 128/192/256 bits key mode, ECB/CBC/CTR chain mode, Slave/FIFO mode
 - ◆ Support DES/3DES (ECB and CBC chain mode) , 3DES (EDE/ EEE key mode), Slave/FIFO mode
 - ◆ Support SHA1/SHA256/MD5 (with hardware padding) HASH function, FIFO mode only
 - ◆ Support 160 bit Pseudo Random Number Generator (PRNG)
 - ◆ Support PKA 512/1024/2048 bit Exp Modulator

1.1.7 Camera interface

- ISP
 - Generic Sensor Interface with programmable polarity for synchronization signals
 - ITU-R BT 601/656 compliant video interface supporting YCbCr or RGB Bayer data
 - 12 bit camera interface
 - 12 bit resolution per color component internally
 - YCbCr 4:2:2 processing
 - Flash light control
 - Mechanical shutter support
 - Windowing and frame synchronization
 - Frame skip support for video (e.g. MPEG-4) encoding
 - Macro block line, frame end, capture error, data loss interrupts and sync. (h_start, v_start) interrupts
 - Luminance/chrominance and chrominance blue/red swapping for YUV input signals
 - Continuous resize support
 - Buffer in system memory organized as ring-buffer
 - Buffer overflow protection for raw data
 - Asynchronous reset input, software reset for the entire IP and separate software resets for all sub-modules
 - Interconnect test support
 - Semi planar storage format
 - Color processing (contrast, saturation, brightness, hue, offset, range)
 - Power management by software controlled clock disabling of currently not needed sub-modules
 - Read port provided to read back a picture from system memory
 - Black level compensation
 - Four channel Lens shade correction (Vignetting)
 - Auto focus measurement
 - White balancing and black level measurement
 - Auto exposure support by brightness measurement in 5x5 sub windows
 - Defect pixel cluster correction unit (DPCC) supports on the fly and table based pixel correction
 - De-noising pre filter (DPF)
 - Enhanced color interpolation (RGB Bayer demosaic)
 - Chromatic aberration correction
 - Combined edge sensitive Sharpening / Blurring filter (Noise filter)
 - Color correction matrix (cross talk matrix)

- Image Stabilization support and Video Stabilization Measurement
- Flexible Histogram calculation
- Digital image effects (Emboss, Sketch, Sepia, B/W (Grayscale), Color Selection, Negative image, sharpening)
- Solarize effect through gamma correction
- AXI 64 bit interface 32Bit Address range (two DMA-write ports and one DMA-read port)
- Up to 16 Beat Bursts depending on configured FIFO size
- 32 bit AHB programming interface
- Maximum input resolution of 3264x2448 pixels
- Main scaler with pixel-accurate up- and down-scaling to any resolution between 3264x2448 and 32x16 pixel in processing mode
- Self scaler with pixel-accurate up- and down-scaling to any resolution between 1920x1080 and 32x16 pixel in processing mode
- Support of semiplanar NV21 color storage format
- Support of image cropping
- Support Y12BIT and UV 8BIT path output after GAMMAOUT module
- Support RGB output after GAMMAOUT module
- Support hurry for latency FIFO
- Support Two-in-one RK-Tone-Mapping with wide dynamic range unit (Block/Global WDR)
- Support Video Stabilization Measurement (VSM) Programming update to 3264x2448
- CIF
 - Support YCbCr422 input
 - Support Raw8bit input
 - Support CCIR656(PAL/NTSC) input
 - Support 1/2/4 channels mixed data of CCIR656 input
 - Support JPEG input
 - Support YCbCr422/420 output
 - Support UYVY/VYUY/YUYV/YVYU configurable
 - Support up to 8192x8192 resolution source
 - Support picture in picture
 - Support arbitrary size window crop
 - Support error/terminate interrupt and combined interrupt output
 - Support clk/vsync/href polarity configurable
 - Support one frame stop/ping-pong mode
- TV DECODER
 - Support formats
 - ◆ PAL
 - ◆ NTSC
 - ◆ NTSC or PAL standard is automatically selected depending on the detected input line standard
 - Support auto gain control
- VADC
 - Sample frequency up to 54MHz
 - Support 2's complement 10bit output
 - The gain of programmable amplifier can be adjusted from 0.5 to 2
 - Support internal buffer circuit
 - Support low pass filter

1.1.8 Video CODEC

- Video Decoder
 - Real-time video decoder of H.264
 - Supports frame timeout interrupt , frame finish interrupt and bit stream error interrupt
 - Error detection and concealment support for all video formats
 - Output data format YUV420 semi-planar,YUV400(monochrome) ,YUV422 is supported by H.264
 - H.264 8bit up to HP level 5.0 : 1440p@30fps (2560x1440)
- Video Encoder
 - Support video encoder for H.264 UP to HP@level4.2
 - Only support I and P slices ,not B slices
 - Support CBR and VBR
 - Support 8-area OSD insertion
 - Support Link table configuration for high frame rate application
 - Support ROI
 - Support Slice split
 - Support Low latency encoding
 - Support Color domain conversion
 - Support Cropping and mirror
 - Support De-noise and enhancement
 - Input data format:
 - ◆ YCbCr 4:2:0 planar
 - ◆ YCbCr 4:2:0 semi-planar
 - ◆ YCbCr 4:2:2 planar
 - ◆ YCbCr 4:2:2 semi-planar
 - ◆ YCbYCr 4:2:2 interleaved
 - ◆ YCbCr 4:4:4 planar
 - ◆ YCbCr 4:4:4 semi-planar
 - ◆ RBG565
 - ◆ RBG888
 - ◆ ARBG8888
 - Output Bit stream of H.264 "slice_layer_without_partitioning_rbsp()"
 - Output ME results(SAD and MV) for each 16x16 block (optional)
 - Image size is from 128x128 to 4096x2304
 - Maximum frame rate is up to 2560x1440@30fps + 1280x720@30fps

1.1.9 JPEG CODEC

- JPEG decoder
 - Input JPEG file : YCbCr 4:0:0, 4:2:0, 4:2:2, 4:4:0, 4:1:1 and 4:4:4 sampling formats
 - Output raw image : YCbCr 4:0:0, 4:2:0, 4:2:2, 4:4:0, 4:1:1 and 4:4:4 semi-planar
 - Decoder size is from 48x48 to 8176x8176(66.8Mpixels)
 - Support JPEG ROI(region of image) decode
 - Maximum data rate[®] is up to 76million pixels per second
 - Embedded memory management unit(MMU)

1.1.10 Image Enhancement (IEP module)

- Image format support
 - Input data: YUV420/YUV422
 - Output data: YUV420/YUV422
 - YUV swap
 - UV SP/P
 - BT601_l/BT601_f/BT709_l/BT709_f color space conversion
 - YUV up/down sampling
- De-interlace
 - 3x5 Y motion detection matrix
 - Source width up to 720x576, 720x480
 - Configured high frequency de-interlace
 - I4O2 (Input 4 field, output 2 frame) /I4O1B/I4O1T/I2O1B/I2O1T mode
- Interface
 - 32bit AHB bus slave
 - 64bit AXI bus master
 - Combined interrupt output

1.1.11 Graphics Engine

- 2D Graphics Engine(RGA module) :
 - Source formats :
 - ◆ ABGR8888, XBGR888, ARGB8888, XRGB888
 - ◆ RGB888, RGB565
 - ◆ RGBA5551, RGBA4444
 - ◆ YUV420 planar, YUV420 semi-planar
 - ◆ YUV422 planar, YUV422 semi-planar
 - ◆ YUV 10-bit for YUV420/422 semi-planar
 - ◆ BPP8, BPP4, BPP2, BPP1
 - Destination formats :
 - ◆ ABGR8888, XBGR888, ARGB8888, XRGB888
 - ◆ RGB888, RGB565
 - ◆ RGBA5551, RGBA4444
 - ◆ YUV420 planar, YUV420 semi-planar
 - ◆ YUV422 planar, YUV422 semi-planar
 - Pixel Format conversion, BT.601/BT.709
 - Max resolution: 8192x8192 source, 4096x4096 destination
 - BitBLT
 - ◆ Two source BitBLT:
 - ◆ A+B=B only BitBLT, A support rotate & scale when B fixed
 - ◆ A+B=C second source (B) has same attribute with (C) plus rotation function
 - Color fill with gradient fill, and pattern fill
 - High-performance stretch and shrink
 - Monochrome expansion for text rendering
 - New comprehensive per-pixel alpha(color/alpha channel separately)
 - Alpha blending modes including Java 2 Porter-Duff compositing blending rules , chroma key, pattern mask, fading
 - Dither operation
 - 0, 90, 180, 270 degree rotation
 - x-mirror, y-mirror & rotation operation

1.1.12 Video OUT

- Display Interface
 - Support HDMI 1.4 output up to 1080p@60Hz
 - TV Interface: TV encoder 10bit out for DAC
 - HDMI Interface : 24 bit(RGB888 YCbCr444),

- Max output resolution 1080p for HDMI, 720p for MIPI, 480i/576i for CVBS
- Display process
 - Background layer: programmable 24-bit color
 - Win0 layer
 - ◆ RGB888, ARGB888, RGB565, YCbCr422, YCbCr420, YCbCr444
 - ◆ RB/alpha/mid/uv swap
 - ◆ 1/8 to 8 scaling-down and scaling-up engine
 - ◆ Support virtual display
 - ◆ 256 level alpha blending (pre-multiplied alpha support)
 - ◆ Transparency color key
 - ◆ De-flicker support for interlace output
 - ◆ YCbCr2RGB(rec601-mpeg/ rec601-jpeg/rec709)
 - ◆ RGB2YCbCr(BT601/BT709)
 - Win1 layer
 - ◆ RGB888, ARGB888, RGB565
 - ◆ RB/alpha/endian swap
 - ◆ Support virtual display
 - ◆ 256 level alpha blending (pre-multiplied alpha support)
 - ◆ Transparency color key
 - ◆ Direct path support
 - ◆ RGB2YCbCr(BT601/BT709)
- Others
 - Win0 layer and Win1 layer overlay exchangeable
 - BCSH(Brightness, Contrast, Saturation, Hue adjustment)
 - BCSH:YCbCr2RGB(rec601-mpeg/ rec601-jpeg/rec709)
 - BCSH:RGB2YCbCr(BT601/BT709)
 - Support Gamma adjust for PAD
 - Support dither down allegro RGB888to666 RGB888to565 & dither down frc (configurable) RGB888to666
 - Blank and black display
 - Standby mode
 - Support RB/RG/BG/delta/dummy swap

1.1.13 HDMI

- Support RGB888 1080p @ 60fps
- HPD input analog comparator
- Compliance HDMI compliance Test specification 1.4
- Support multi-channels PCM or compressed audio transmission (32-192kHz Fs) from I2S, using IEC60958 and IEC 61937

1.1.14 MIPI DSI

- Support RGB888 720p @ 60fps
- Support 4 lanes
- Support command mode
- Compliance MIPI Alliance Standard for Display Pixel Interface (DPI-2)

1.1.15 Audio Interface

- I2S0/ with 8ch
 - I2S0/I2S1 supports up to 8 channels (8xTX, 8xRX)
 - Audio resolution from 16bits to 32bits
 - Sample rate up to 192KHz
 - Provides master and slave work mode, software configurable
 - Support 3 I2S formats (normal, left-justified, right-justified)
 - Support 4 PCM formats(early, late1, late2, late3)
 - I2S and PCM mode cannot be used at the same time

- I2S1/I2S2(PCM) with 2ch
 - Up to 2 channels (2xTX, 2xRX)
 - Audio resolution from 16bits to 32bits
 - Sample rate up to 192KHz
 - Provides master and slave work mode, software configurable
 - Support 3 I2S formats (normal , left-justified , right-justified)
 - Support 4 PCM formats(early , late1 , late2 , late3)
 - I2S and PCM cannot be used at the same time

- Audio CODEC
 - 24bit DAC
 - Support Line-out
 - Support Mono, Stereo, 5.1 HiFi channel performance
 - Integrated digital interpolation and decimation filter.
 - Sampling rate of 8kHz/12kHz/16kHz/24kHz/32kHz/44.1KHz/48KHz/96KHz
 - Optional fractional PLL available that support 6MHz to 20MHz clock input to any clock
 - Support PCM/I2S Mode
 - Support MIC single-ended/double-ended difference input

1.1.16 Connectivity

- SDIO interface
 - Compatible with SDIO 3.0 protocol
 - 4bits data bus widths

- GMAC 10/100M Ethernet Controller
 - Supports 10/100-Mbps data transfer rates with the RMI interfaces
 - Supports both full-duplex and half-duplex operation
 - ◆ Supports CSMA/CD Protocol for half-duplex operation
 - ◆ Supports IEEE 802.3x flow control for full-duplex operation
 - ◆ Optional forwarding of received pause control frames to the user application in full-duplex operation
 - ◆ Back-pressure support for half-duplex operation
 - ◆ Automatic transmission of zero-quanta pause frame on de-assertion of flow control input in full-duplex operation
 - Preamble and start-of-frame data (SFD) insertion in Transmit, and deletion in Receive paths
 - Automatic CRC and pad generation controllable on a per-frame basis
 - Options for Automatic Pad/CRC Stripping on receive frames
 - Programmable Inter-Frame-Gap (40-96 bit times in steps of 8)
 - Supports a variety of flexible address filtering modes
 - Separate 32-bit status returned for transmission and reception packets
 - Supports IEEE 802.1Q VLAN tag detection for reception frames
 - Support detection of LAN wake-up frames and AMD Magic Packet frames
 - Support checksum off-load for received IPv4 and TCP packets encapsulated by the Ethernet frame
 - Support checking IPv4 header checksum and TCP, UDP, or ICMP checksum encapsulated in IPv4 or IPv6 datagram
 - Comprehensive status reporting for normal operation and transfers with errors
 - Automatic generation of PAUSE frame control or backpressure signal to the GMAC core based on Receive FIFO-fill (threshold configurable) level
 - Handles automatic retransmission of Collision frames for transmission
 - Discards frames on late collision, excessive collisions, excessive deferral and under-run conditions

- SPI Controller
 - Support serial-master and serial-slave mode, software-configurable
 - DMA-based or interrupt-based operation
 - Embedded two 32x16bits FIFO for TX and RX operation respectively
 - Support 2 chip-selects output in serial-master mode
- SFC
 - Support one chip select
 - Support x1,x2,x4 data bits mode
 - Support interrupt output, interrupt maskable
 - Support Spansion, MXIC ,Gigadevice ...vendor's nor flash memory.
- UART Controller
 - 3 on-chip UART controller inside RK1108
 - DMA-based or interrupt-based operation
 - UART0/1/2 Embedded two 64Bytes FIFO for TX and RX operation respectively
 - Support 5bit,6bit,7bit,8bit serial data transmit or receive
 - Standard asynchronous communication bits such as start, stop and parity
 - Support different input clock for UART operation to get up to 4Mbps or other special baud rate
 - Support non-integer clock divides for baud clock generation
 - Support auto flow control mode
- I2C controller
 - 4 on-chip I2C controller in RK1108
 - Multi-master I2C operation
 - Support 7bits and 10bits address mode
 - Software programmable clock frequency and transfer rate up to 400Kbit/s in the fast mode
 - Serial 8bits oriented and bidirectional data transfers can be made at up to 100Kbit/s in the standard mode
- GPIO
 - 4 groups of GPIO (GPIO0~GPIO3) , 32 GPIOs per group in GPIO0~GPIO3, totally have 128 GPIOs
 - All of GPIOs can be used to generate interrupt to Cortex-A7
 - All of pull-up GPIOs are software-programmable for pull-up resistor or not
 - All of pull-down GPIOs are software-programmable for pull-down resistor or not
 - All of GPIOs are always in input direction in default after power-on-reset
- USB Host2.0
 - Embedded 3 USB Host 2.0 interfaces
 - Compatible with USB Host2.0 specification
 - Supports high-speed(480Mbps), full-speed(12Mbps) and low-speed(1.5Mbps) mode
 - Provides 16 host mode channels
 - Support periodic out channel in host mode
- USB OTG2.0
 - Compatible with USB OTG2.0 specification
 - Supports high-speed(480Mbps), full-speed(12Mbps) and low-speed(1.5Mbps) mode
 - Support up to 9 device mode endpoints in addition to control endpoint 0
 - Support up to 6 device mode IN endpoints including control endpoint 0
 - Endpoints 1/3/5/7 can be used only as data IN endpoint
 - Endpoints 2/4/6 can be used only as data OUT endpoint
 - Endpoints 8/9 can be used as data OUT and IN endpoint

- Provides 9 host mode channels

1.1.17 Others

- Temperature Sensor(TS-ADC)
 - 10-bits ADC up to 50KS/s sampling rate
 - -40~125C temperature range and 5C temperature resolution
- Successive Approximation ADC (SARADC)
 - 10-bit resolution
 - Up to 1MS/s sampling rate
 - 6 single-ended input channels
 - Current consumption: 0.5mA @ 1MS/s
- eFuse
 - Two high-density electrical Fuse is integrated: two 256bits (32x8)
 - Support standby mode
 - Provide inactive mode, VP must be 0V or Floating in this mode.
- Package Type
 - BGA356 (body: 14mm x 14mm ; ball size : 0.3mm ; ball pitch : 0.65mm;)
 - Support both MCP with 128M DDR3 and single package only.

Notes :

①: *DDR3 are not used simultaneously*

②: *Actual maximum frame rate will depend on the clock frequency and system bus performance*

③: *Actual maximum data rate will depend on the clock frequency and JPEG compression rate*

1.2 Block Diagram

The following diagram shows the basic block diagram for RK1108

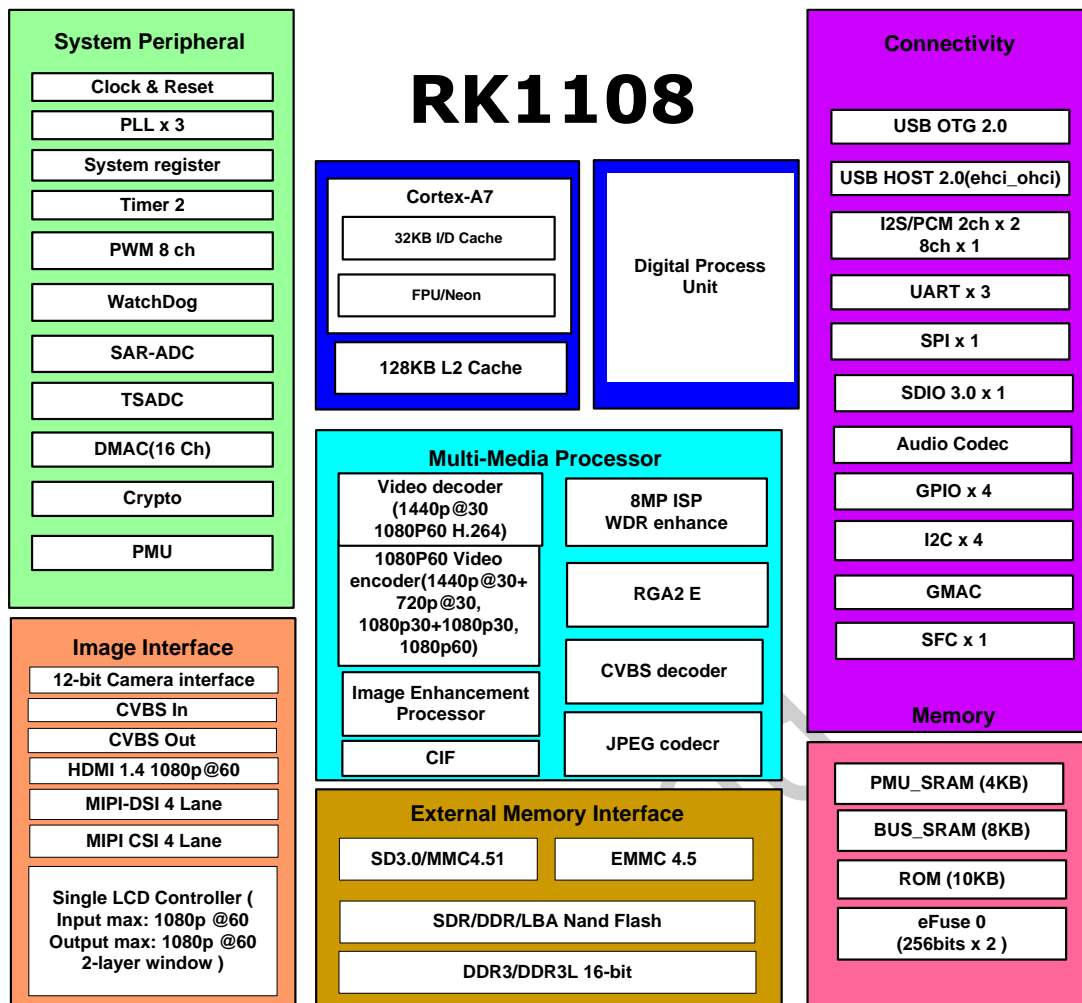

Fig. 1-1 RK1108 Block Diagram

Chapter 2 Package Information

2.1 Ordering information

Orderable Device	ROHS Status	Package	Package Qty	Device special feature
RK1108A	ROHS	TFBGA(HF)	1190	Cortex A7 + DSP 1440P30/1080P60
RK1108B	ROHS	TFBGA(HF)	1190	Cortex A7 + DSP + 128MB DDR3 1080P30

2.2 Top Marking



Rockchip: Brand Name

RKXXXXX: Chip Name

ABC: Subcontractor Code
XXXXXXXX: Die Lot NO#
DEFG: Date Code
 • The first pin



Rockchip: Brand Name

RKXXXXX: Chip Name

ABC: Subcontractor Code
XXXXXXXX: Die Lot NO#
DEFG: Date Code
 • The first pin

2.3 Dimension

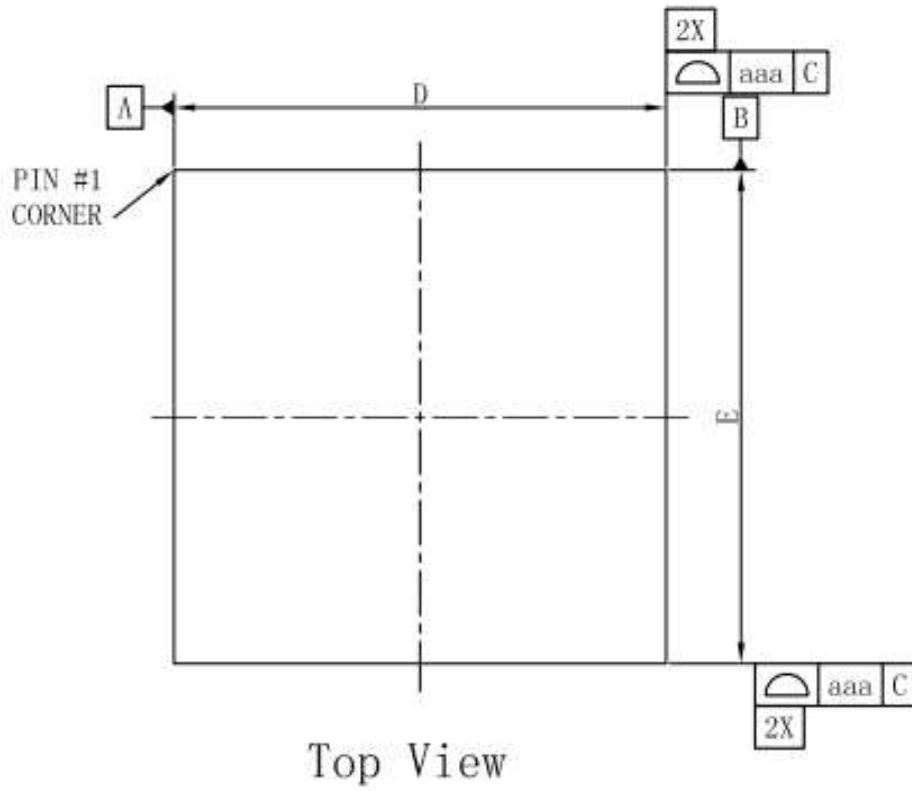

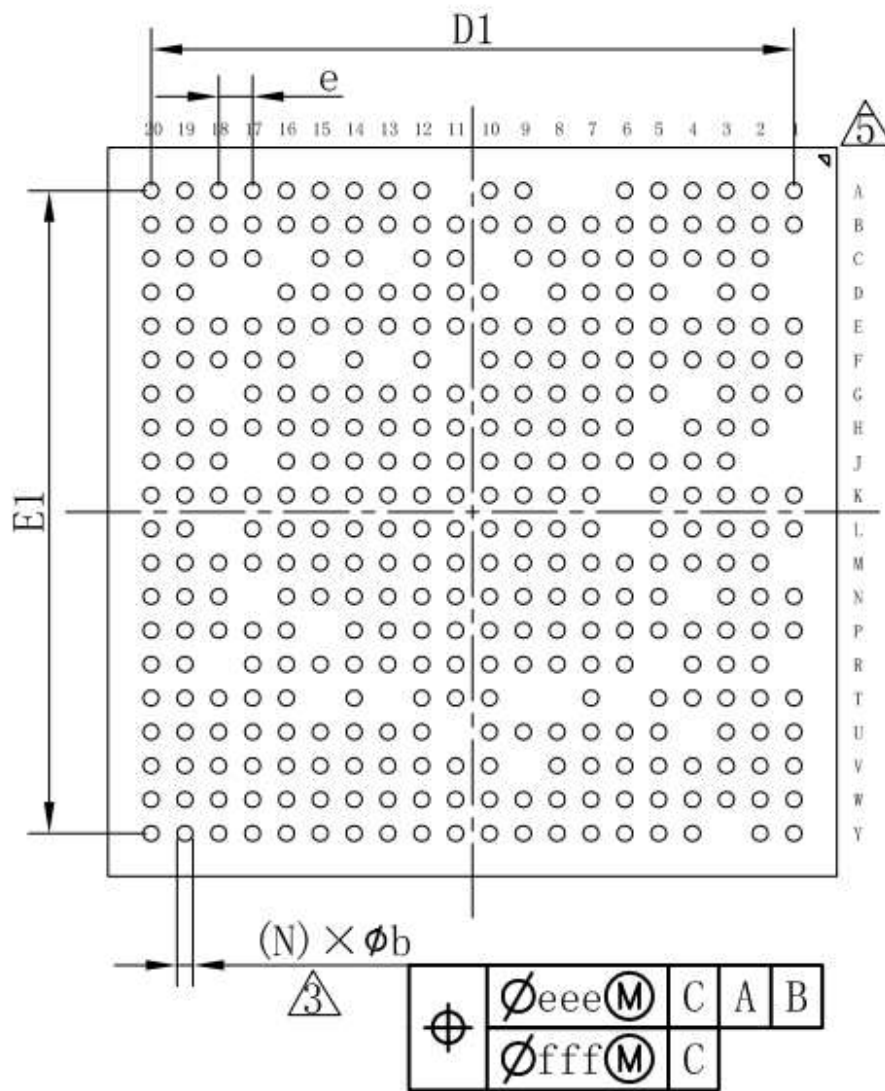
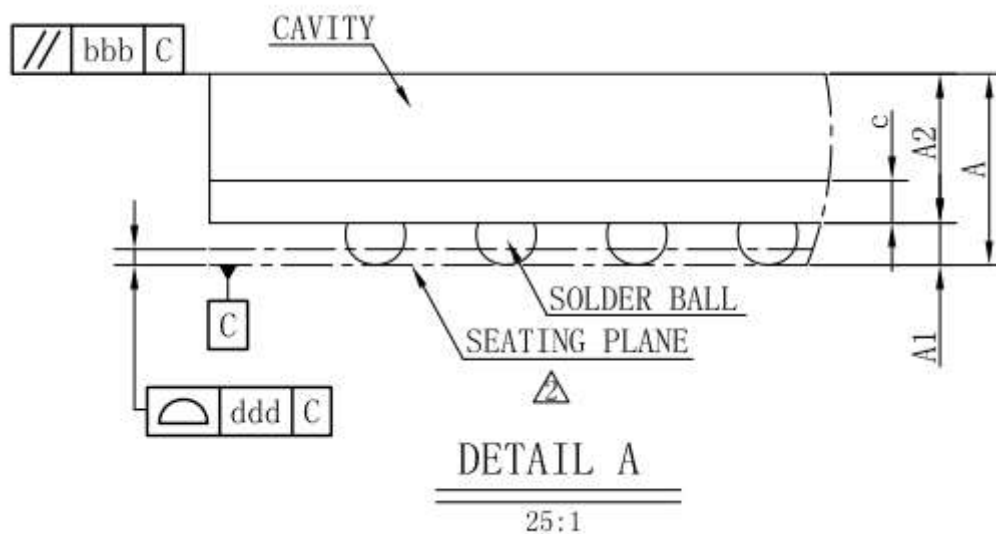
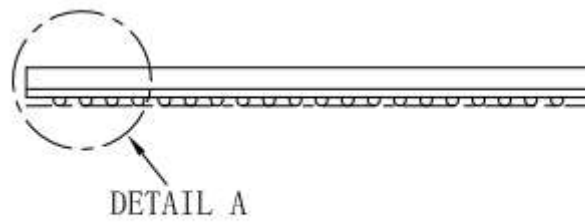

Fig. 2-1 RK1108 BGA359 Package Top View and bottom view





Side View

Fig. 2-2 RK1108 BGA359 Package Side View

symbol	Dimension in mm			Dimension in inch		
	MIN	NOM	MAX	MIN	NOM	MAX
A	---	---	1.100	---	---	0.043
A1	0.160	0.210	0.260	0.006	0.008	0.010
A2	0.690	0.740	0.810	0.027	0.029	0.032
c	0.170	0.210	0.250	0.007	0.008	0.010
D	13.900	14.000	14.100	0.547	0.551	0.555
E	13.900	14.000	14.100	0.547	0.551	0.555
D1	---	12.350	---	---	0.486	---
E1	---	12.350	---	---	0.486	---
e	---	0.650	---	---	0.026	---
b	0.250	0.300	0.350	0.010	0.012	0.014
aaa	0.100			0.004		
bbb	0.100			0.004		
ddd	0.080			0.003		
eee	0.150			0.006		
fff	0.080			0.003		
Ball Diam	0.300			0.012		
N	359			359		
MD/ME	20/20			20/20		

Fig. 2-3 RK1108 BGA359 Package Dimension

2.4 Ball Map

	1	2	3	4	5	6	7	8	9	10
A	VSS_1	DDR_A7	DDR_A2	VSS_89	DDR_A14	DDR_A6	NP	NP	VSS_95	DDR_A8
B	DDR_CS ON	DDR_BA0	DDR_A5	DDR_A0	DDR_A11	DDR_A4	DDR_A12	VSS_98	DDR_CK E	DDR_A1

C	NP	DDR_CL KN	DDR_CL K	VSS_97	DDR_OD T0	VSS_90	VSS_96	DDR_BA1	DDR_A10	NP
D	NP	VSS_88	DDR_DQ 4	NP	DDR_RA SN	DDR_BA2	DDR_A13	DDR_CA SN	NP	ADC_IN3
E	VSS_85	DDR_DQ 1	DDR_DQ 7	FP_1	VSS_100	DDR_A3	DDR_A9	DDR_WE N	VSS_93	DDR_VD D_4
F	DDR_DQ 3	VSS_87	DDR_DQ 0	DDR_DQ 6	DDR_RE SET	FP_2	DDR_VD D_5	DDR_VD D_6	DDR_VD D_7	VSS_11
G	DDR_DM 0	DDR_DQ 5	VSS_86	NP	DDR_DQ 2	DDR_VD D_3	VSS_37	CORE_V DD_1	CORE_V DD_2	VSS_8

11	12	13	14	15	16	17	18	19	20	
NP	GPIO3_C2/SDMMC0_D0/UART2_TX	GPIO3_C5/SDMMC0_PWR	VIDEO_IN_P	CODEC_A_OL	CODEC_A_OR	CODEC_M_ICBIAS	GPIO1_D0/UART0_CTSN/SPI_CLK/DSP_TCK	GPIO1_D1/UART0_RTSN/SPI_CSN0/DSP_TMS	GPIO1_D7/HDMI_CE_C/DSP_RTCK	A
SADC_AVDD_1V8	GPIO3_C3/SDMMC0_CLKO	GPIO3_C4/SDMMC0_CMD	VIDEO_IN_N	CODEC_M_ICR	CODEC_V_CM	VSS_6	GPIO1_D3/UART0_TX/SPI_TXD/D	VSS_2	GPIO1_B3/LCDC_D16/I2S_SCLK/GMAC_TXD1	B
VSS_72	GPIO3_C0/SDMMC0_D2	NP	VIDEO_AVDD_1V8	CODEC_M_ICL	NP	5VGPIO1_D5/UART2_RTSN/HDMI_I2C0_SDA	5VGPIO1_D6/HDMI_HPD0	GPIO1_B4/LCDC_D15/I2S_MCLK/GMAC_TXEN	GPIO1_B6/LCDC_D13/I2S_LRC_LKTX/GMAC_RXD1	C
GPIO3_B7/SDMMC0_D3	GPIO3_C1/SDMMC0_D1/UART2_RX	ADC_IN0	VSS_69	CODEC_A_VDD_1V8	VSS_60	NP	NP	GPIO1_D2/UART0_RXSPI_RXD/D	GPIO1_C2/LCDC_DE_N/I2S_SDI03/GMAC_RXER	D
ADC_IN5	ADC_IN2	ADC_IN1	VIDEO_AVDD_1V0	CODEC_A_VSS	GPIO2_D2/UART2_TX/JTAG_TCK	5VGPIO1_D4/UART2_CTSN/HDMI_I2C0_SCL	GPIO1_C0/LCDC_D11/I2S_LRC_LKRX	GPIO1_C1/LCDC_D10/I2S_SDI0/PWM4	GPIO1_C3/LCDC_VSYN/GMAC_MDIO	E
NP	ADC_IN4	NP	GPIO3_VDD	NP	GPIO2_D1/UART2_RX/JTAG_TMS	GPIO1_B2/LCDC_D17/I2S_SDO/GMAC_TXD0	GPIO1_B5/LCDC_D14/I2S_SDI01/GMAC_RXD0	GPIO1_C4/LCDC_HSYN/GMAC_MDC	GPIO2_B1/FLASH_CLE	F
VSS_92	VSS_102	VSS_7	VSS_10	CORE_VDD_4	GPIO1_B7/LCDC_D12/I2S_SDI02/GMAC_RXDV	GPIO1_C5/LCDC_CLK/GMAC_CLK	NP	GPIO2_B4/FLASH_RDY/EMMC_CMD/SFC_CSN0	GPIO2_A4/FLASH_D4/EMMC_D4	G

	1	2	3	4	5	6	7	8	9	10
H	NP	DDR_DQS ₁	DDR_DQS _{1N}	DDR_DQ ₃	NP	DDR_VDD ₂	VSS_91	VSS_14	VSS_15	VSS_16
J	NP	NP	DDR_DQS ₀	DDR_DQ ₉	VSS_73	DDR_VDD ₁	CORE_VD _{D7}	VSS_22	VSS_23	VSS_24
K	VSS_99	DDR_DQ ₈	VSS_4	DDR_DQS _{0N}	DDR_DQ ₂	NP	VSS_29	VSS_30	VSS_31	VSS_32
L	DDR_DQ ₅	DDR_DQ ₁	DDR_DM ₁	DDR_DQ ₄	VSS_13	NP	VSS_5	VSS_38	VSS_39	VSS_40
M	NP	DDR_DQ ₀	GPIO0_A7 /SPI_TXD	GPIO0_C0 /PWM3/IR	GPIO0_B7 /TSADC_S HUT	PLL_AVDD_1V0	VSS_45	VSS_46	VSS_47	VSS_48
N	GPIO0_B6 /I2C3_SCL	VSS_74	EFUSE	NP	GPIO0_B5 /PMIC_SL EEP	PLL_AVDD_1V8	VSS_53	VSS_54	VSS_55	VSS_56
P	XIN_24M	XOUT24M	VSS_61	GPIO0_A3 /SPI_CLK	GPIO0_A4 /SPI_CSN ₀	GPIO0_C3 /PMU_DE BUG2	TEST	VSS_62	VSS_63	VSS_64
R	NP	GPIO0_B3	GPIO0_C6 /PWM2/P MU_DEBU G4	GPIO0_B2 /I2C0_SDA	NP	PMU_DVDD_1V0	CORE_VD _{D8}	PMUIO_V DD	VSS_71	VSS_44

11	12	13	14	15	16	17	18	19	20	
VSS_17	VSS_18	VSS_19	VSS_20	VSS_105	APIO1_VD D	GPIO2_C2 /FLASH_ WP/EMMC_C_PWR/	GPIO2_B0 /FLASH_A LE	GPIO2_A3 /FLASH_D 3/EMMC_ D3/SFC_H OLD_IO3	GPIO2_A7 /FLASH_D 7/EMMC_ D7	H
VSS_25	VSS_26	VSS_27	VSS_103	CORE_VD D_3	GPIO2_A1 /FLASH_D 1/EMMC_ D1/SFC_S IO_IO1	NP	GPIO2_B7 /FLASH_C S1/SFC_C LK	GPIO2_A5 /FLASH_D 5/EMMC_ D5	GPIO2_B5 /FLASH_C S0/	J
VSS_33	VSS_34	VSS_35	VSS_36	VSS_106	APIO6_VD D	GPIO2_A2 /FLASH_D 2/EMMC_ D2/SFC_ WP_IO2	GPIO2_A0 /FLASH_D 0/EMMC_ D0/SFC_S IO_IO0	GPIO2_B2 /FLASH_ WRN	GPIO2_B6 /EMMC_C LKO/	K
VSS_41	VSS_42	VSS_43	VSS_28	CORE_VD D_6	GPIO2_A6 /FLASH_D 6/EMMC_ D6	GPIO2_B3 /FLASH_R DN	NP	GPIO2_D7 /SDIO_D0	GPIO2_D6 /SDIO_CM D	L
VSS_49	VSS_50	VSS_51	VSS_52	VSS_70	VSS_104	GPIO3_A2 /SDIO_D3	GPIO3_A0 /SDIO_D1	GPIO2_D5 /SDIO_CL KO	GPIO3_A1 /SDIO_D2	M

VSS_57	VSS_58	VSS_59	VSS_12	CORE_VD D_5	GPIO3_B1 /PCM_OUT/ FLASH_TRIG_OUT	NP	GPIO3_B2 /PCM_IN/ FLASH_TRIG_IN	GPIO3_B6	GPIO3_B4 /PCM_SYNC/ PRELIGHT_OUT	N
VSS_65	VSS_66	VSS_67	VSS_68	NP	GPIO3_VD D	GPIO3_A6 /UART1_TX	GPIO3_A4 /UART1_CTSN	GPIO3_A7	GPIO3_B5 /MIPI_CSI_MCLK	P
VSS_101	VSS_9	VSS_75	VSS_76	VSS_94	GPIO3_D5 /CIF_D10/ FLASH_TRIG_OUT	GPIO2_D4 /I2C1_SCL	NP	GPIO3_B3 /PCM_CLK	GPIO3_A3 /UART1_RTSN	R

	1	2	3	4	5	6	7	8	9	10
T	NPOR	GPIO0_C5 /PWM0_P MU_DEBUG3	GPIO0_C4 /PWM1/I2C3_SDA	GPIO0_B1 /I2C0_SCL	GPIO0_B4	NP	GPIO0_A1 /SDMMC0_DET	NP	NP	USB_AVDD_1V8
U	GPIO0_A2 /SDMMC1_PWR	GPIO0_C2 /PMU_DEBUG1	GPIO0_C1 /HDMI_HP D1/CVBS_CLK_IN	NP	GPIO0_B0 /SPI_RXD	HDMI_EXTR	VDAC_AVDD_1V8	MIPI_DSL_AVDD_1V8	MIPI_DSL_AVDD_3V3	USB_EXT R
V	GPIO0_A6 /PMU_DEBUG0	GPIO0_A5 /CLK_WIFI_OUT	HDMI_AVDD_1V8	VSS_78	HDMI_AVDD_1V0	VSS_79	MIPI_DSL_AVDD_1V0	VSS_80	NP	VSS_81
W	HDMI_TXCP	HDMI_TX0N	HDMI_TX0P	HDMI_TX1N	HDMI_TX2P	VDAC_EXTR	GPIO1_B1 /LCDC_D9 /MIPI_D3N /PWM7	GPIO1_A7 /LCDC_D7 /MIPI_D2N /PWM5	GPIO1_A1 /LCDC_D1 /MIPI_CLKN	GPIO1_A4 /LCDC_D4 /MIPI_D1P
Y	HDMI_TXCN	VSS_77	NP	HDMI_TX1P	HDMI_TX2N	VDAC_OUT	GPIO1_B0 /LCDC_D8 /MIPI_D3P /PWM6	GPIO1_A6 /LCDC_D6 /MIPI_D2P	GPIO1_A0 /LCDC_D0 /MIPI_CLKP	GPIO1_A5 /LCDC_D5 /MIPI_D1N

USB_AVDD_3V3	USB_VDD_1V0	NP	VSS_21	NP	GPIO2_VD D	GPIO3_D1 /CIF_PDN	GPIO3_C7 /CIF_CLKIN	GPIO2_D3 /I2C1_SDA	GPIO3_A5 /UART1_RX	T
11	12	13	14	15	16	17	18	19	20	
NP	MIPI_CSI_EXTR	MIPI_CSI_AVDD_1V0	GPIO2_C1 /CIF_D7/I2S_SDI	GPIO2_C5 /CIF_D2/I2S_MCLK	GPIO2_C4 /CIF_D1/I2S_SCLK	GPIO3_D4 /CIF_D9/ FLASH_TRIG_IN	GPIO3_D0 /CIF_HREF	GPIO1_C7 /CIF_D5/I2S_SDIO2	GPIO3_B0	U
USB0_ID	USB_VBUS	VSS_82	GPIO2_C6 /CIF_D3/I2S_SDIO1	VSS_83	GPIO2_C3 /CIF_D0/I2S_SDO	VSS_84	GPIO3_D2 /CIF_CLKOUT	GPIO3_C6 /CIF_VSYNC	GPIO1_C6 /CIF_D4/I2S_LRCLKTX	V
GPIO1_A2 /LCDC_D2 /MIPI_D0P	USB0_DP	USB1_DP	MIPI_CSI_D0N	MIPI_CSI_D1N	MIPI_CSI_CLKP	MIPI_CSI_D2N	MIPI_CSI_D3P	VSS_3	GPIO3_D6 /CIF_D11/ PRELIGHT_OUT	W
GPIO1_A3 /LCDC_D3 /MIPI_D0N	USB0_DM	USB1_DM	MIPI_CSI_D0P	MIPI_CSI_D1P	MIPI_CSI_CLKN	MIPI_CSI_D2P	MIPI_CSI_D3N	GPIO2_C0 /CIF_D6/I2S_LRCLKRX	GPIO3_D3 /CIF_D8/I2S_SDIO3	Y

Fig. 2-4 RK1108A BGA 359 Ball Map

	1	2	3	4	5	6	7	8	9	10
A	VSS_1	VSS_107	VSS_108	VSS_89	DDR_VDD_15	VSS_115	NP	NP	VSS_95	DDR_VDD_23
B	VSS_109	VSS_110	VSS_111	VSS_112	DDR_VDD_16	VSS_113	VSS_114	VSS_98	VSS_116	DDR_VDD_24
C	NP	DDR_VDD_12	DDR_VDD_13	VSS_97	DDR_VDD_17	VSS_90	VSS_96	DDR_VDD_22	VSS_117	NP
D	NP	VSS_88	DDR_VDD_14	NP	DDR_VDD_18	DDR_VDD_19	DDR_VDD_20	DDR_VDD_21	NP	ADC_IN3
E	VSS_85	VSS_122	VSS_123	PZQ	VSS_100	DDR_VDD_25	DDR_VDD_26	DDR_VDD_27	VSS_93	DDR_VDD_4
F	VSS_121	VSS_87	VSS_124	VSS_125	VSS_126	VREF	DDR_VDD_5	DDR_VDD_6	DDR_VDD_7	VSS_11
G	VSS_118	VSS_119	VSS_86	NP	DDR_VDD_11	DDR_VDD_3	VSS_37	CORE_VD_D1	CORE_VD_D2	VSS_8

	1	2	3	4	5	6	7	8	9	10
H	NP	DDR_VDD_8	DDR_VDD_9	DDR_VDD_10	NP	DDR_VDD_2	VSS_91	VSS_14	VSS_15	VSS_16
J	NP	NP	VSS_127	VSS_128	VSS_73	DDR_VDD_1	CORE_VD_D7	VSS_22	VSS_23	VSS_24
K	VSS_99	VSS_129	VSS_4	VSS_130	VSS_135	NP	VSS_29	VSS_30	VSS_31	VSS_32
L	VSS_131	VSS_132	VSS_133	VSS_120	VSS_13	NP	VSS_5	VSS_38	VSS_39	VSS_40
M	NP	VSS_134	GPIO0_A7 /SPI_TXD	GPIO0_C0 /PWM3/IR	GPIO0_B7 /TSADC_S HUT	PLL_AVDD_1V0	VSS_45	VSS_46	VSS_47	VSS_48

Fig. 2-5 RK1108B BGA 359 Ball Map

Notes:

The pins of RK1108B are different from RK1108A, as follows:

A2,A3 ,A6 ,B1,B2,B3,B4 ,B6,B7,B9,C9,E2,E3,E4,E10,F1,F3,F4,F5,F6,G1,G2,J3,J4,K2,K4,K5,L1,L2,L3,L4,M2 are GND.

A5,A10,B5,B10,C2,C3,C5,C8,D3,D5,D6,D7,D8,E6,E7,E8,F7,F8,F9,G5,G6,H2,H3,H4,H6,J6 are DDR_VDD. As fig.2-5.

2.5 Ball Pin Number Order

Table 2-1 RK1108A BGA359 Pin Number Order Information

Pin Number	Pin Name	Pin Number	Pin Name
A1	VSS_1	L1	DDR_DQ15
A2	DDR_A7	L2	DDR_DQ11
A3	DDR_A2	L3	DDR_DM1
A4	VSS_89	L4	DDR_DQ14
A5	DDR_A14	L5	VSS_13
A6	DDR_A6	L6	NP
A7	NP	L7	VSS_5
A8	NP	L8	VSS_38
A9	VSS_95	L9	VSS_39
A10	DDR_A8	L10	VSS_40
A11	NP	L11	VSS_41
A12	GPIO3_C2/SDMMC0_D0/UART2_TX	L12	VSS_42
A13	GPIO3_C5/SDMMC0_PWR	L13	VSS_43
A14	VIDEO_INP	L14	VSS_28
A15	CODEC_AOL	L15	CORE_VDD_6
A16	CODEC_AOR	L16	GPIO2_A6/FLASH_D6/EMMC_D6
A17	CODEC_MICBIAS	L17	GPIO2_B3/FLASH_RDN
A18	GPIO1_D0/UART0_CTSN/SPI_CLK/DSP_TCK	L18	NP
A19	GPIO1_D1/UART0_RTSN/SPI_CSN0/DSP_TMS	L19	GPIO2_D7/SDIO_D0
A20	GPIO1_D7/HDMI_CEC/DSP_RTCK	L20	GPIO2_D6/SDIO_CMD
B1	DDR_CS0N	M1	NP
B2	DDR_BA0	M2	DDR_DQ10
B3	DDR_A5	M3	GPIO0_A7/SPI_TXD
B4	DDR_A0	M4	GPIO0_C0/PWM3/IR
B5	DDR_A11	M5	GPIO0_B7/TSADC_SHUT
B6	DDR_A4	M6	PLL_AVDD_1V0
B7	DDR_A12	M7	VSS_45
B8	VSS_98	M8	VSS_46
B9	DDR_CKE	M9	VSS_47
B10	DDR_A1	M10	VSS_48
B11	SADC_AVDD_1V8	M11	VSS_49
B12	GPIO3_C3/SDMMC0_CLKO	M12	VSS_50
B13	GPIO3_C4/SDMMC0_CMD	M13	VSS_51
B14	VIDEO_INN	M14	VSS_52

Pin Number	Pin Name	Pin Number	Pin Name
B15	CODEC_MICR	M15	VSS_70
B16	CODEC_VCM	M16	VSS_104
B17	VSS_6	M17	GPIO3_A2/SDIO_D3
B18	GPIO1_D3/UART0_TX/SPI_TXD/D	M18	GPIO3_A0/SDIO_D1
B19	VSS_2	M19	GPIO2_D5/SDIO_CLKO
B20	GPIO1_B3/LCDC_D16/I2S_SCLK/GMAC_TXD1	M20	GPIO3_A1/SDIO_D2
C1	NP	N1	GPIO0_B6/I2C3_SCL
C2	DDR_CLKN	N2	VSS_74
C3	DDR_CLK	N3	EFUSE
C4	VSS_97	N4	NP
C5	DDR_ODT0	N5	GPIO0_B5/PMIC_SLEEP
C6	VSS_90	N6	PLL_AVDD_1V8
C7	VSS_96	N7	VSS_53
C8	DDR_BA1	N8	VSS_54
C9	DDR_A10	N9	VSS_55
C10	NP	N10	VSS_56
C11	VSS_72	N11	VSS_57
C12	GPIO3_C0/SDMMC0_D2	N12	VSS_58
C13	NP	N13	VSS_59
C14	VIDEO_AVDD_1V8	N14	VSS_12
C15	CODEC_MICL	N15	CORE_VDD_5
C16	NP	N16	GPIO3_B1/PCM_OUT/FLASH_TRIG_OUT
C17	5VGPIO1_D5/UART2_RTSN/HDMI_I2C0_SDA	N17	NP
C18	5VGPIO1_D6/HDMI_HPD0	N18	GPIO3_B2/PCM_IN/FLASH_TRIG_IN
C19	GPIO1_B4/LCDC_D15/I2S_MCLK/GMAC_TXEN	N19	GPIO3_B6
C20	GPIO1_B6/LCDC_D13/I2S_LRCLKTX/GMAC_RXD1	N20	GPIO3_B4/PCM_SYNC/PRELIGHT_TRIG_OUT
D1	NP	P1	XIN_24M
D2	VSS_88	P2	XOUT24M
D3	DDR_DQ4	P3	VSS_61
D4	NP	P4	GPIO0_A3/SPI_CLK
D5	DDR_RASN	P5	GPIO0_A4/SPI_CSN0
D6	DDR_BA2	P6	GPIO0_C3/PMU_DEBUG2
D7	DDR_A13	P7	TEST
D8	DDR_CASN	P8	VSS_62
D9	NP	P9	VSS_63
D10	ADC_IN3	P10	VSS_64
D11	GPIO3_B7/SDMMC0_D3	P11	VSS_65
D12	GPIO3_C1/SDMMC0_D1/UART2_RX	P12	VSS_66
D13	ADC_IN0	P13	VSS_67
D14	VSS_69	P14	VSS_68
D15	CODEC_AVDD_1V8	P15	NP
D16	VSS_60	P16	GPIO5_VDD
D17	NP	P17	GPIO3_A6/UART1_TX

Pin Number	Pin Name	Pin Number	Pin Name
D18	NP	P18	GPIO3_A4/UART1_CTSN
D19	GPIO1_D2/UART0_RXSPI_RXD/D	P19	GPIO3_A7
D20	GPIO1_C2/LCDC_DEN/I2S_SDIO3/GMAC_RXER	P20	GPIO3_B5/MIPI_CSI_MCLK
E1	VSS_85	R1	NP
E2	DDR_DQ1	R2	GPIO0_B3
E3	DDR_DQ7	R3	GPIO0_C6/PWM2/PMU_DEBUG4
E4	FP_1	R4	GPIO0_B2/I2C0_SDA
E5	VSS_100	R5	NP
E6	DDR_A3	R6	PMU_DVDD_1V0
E7	DDR_A9	R7	CORE_VDD_8
E8	DDR_WEN	R8	PMUIO_VDD
E9	VSS_93	R9	VSS_71
E10	DDR_VDD_4	R10	VSS_44
E11	ADC_IN5	R11	VSS_101
E12	ADC_IN2	R12	VSS_9
E13	ADC_IN1	R13	VSS_75
E14	VIDEO_AVDD_1V0	R14	VSS_76
E15	CODEC_AVSS	R15	VSS_94
E16	GPIO2_D2/UART2_TX/JTAG_TCK	R16	GPIO3_D5/CIF_D10/FLASH_TRIG_OUT
E17	5VGPIO1_D4/UART2_CTSN/HDMI_I2C0_SCL	R17	GPIO2_D4/I2C1_SCL
E18	GPIO1_C0/LCDC_D11/I2S_LRCLKRX	R18	NP
E19	GPIO1_C1/LCDC_D10/I2S_SDI/PWM4	R19	GPIO3_B3/PCM_CLK
E20	GPIO1_C3/LCDC_VSYNC/GMAC_MDIO	R20	GPIO3_A3/UART1_RTSN
F1	DDR_DQ3	T1	NPOR
F2	VSS_87	T2	GPIO0_C5/PWM0/PMU_DEBUG3
F3	DDR_DQ0	T3	GPIO0_C4/PWM1/I2C3_SDA
F4	DDR_DQ6	T4	GPIO0_B1/I2C0_SCL
F5	DDR_RESET	T5	GPIO0_B4
F6	FP_2	T6	NP
F7	DDR_VDD_5	T7	GPIO0_A1/SDMMC0_DET
F8	DDR_VDD_6	T8	NP
F9	DDR_VDD_7	T9	NP
F10	VSS_11	T10	USB_AVDD_1V8
F11	NP	T11	USB_AVDD_3V3
F12	ADC_IN4	T12	USB_VDD_1V0
F13	NP	T13	NP
F14	APIO3_VDD	T14	VSS_21
F15	NP	T15	NP
F16	GPIO2_D1/UART2_RX/JTAG_TMS	T16	APIO2_VDD
F17	GPIO1_B2/LCDC_D17/I2S_SDO/GMAC_TXD0	T17	GPIO3_D1/CIF_PDN
F18	GPIO1_B5/LCDC_D14/I2S_SDIO1/GMAC_RXD0	T18	GPIO3_C7/CIF_CLKIN
F19	GPIO1_C4/LCDC_HSYNC/GMAC_MDC	T19	GPIO2_D3/I2C1_SDA
F20	GPIO2_B1/FLASH_CLE	T20	GPIO3_A5/UART1_RX

Pin Number	Pin Name	Pin Number	Pin Name
G1	DDR_DM0	U1	GPIO0_A2/SDMMC1_PWR
G2	DDR_DQ5	U2	GPIO0_C2/PMU_DEBUG1
G3	VSS_86	U3	GPIO0_C1/HDMI_HPD1/CVBS_CLK_IN
G4	NP	U4	NP
G5	DDR_DQ2	U5	GPIO0_B0/SPI_RXD
G6	DDR_VDD_3	U6	HDMI_EXTR
G7	VSS_37	U7	VDAC_AVDD_1V8
G8	CORE_VDD_1	U8	MIPI_DSI_AVDD_1V8
G9	CORE_VDD_2	U9	MIPI_DSI_AVDD_3V3
G10	VSS_8	U10	USB_EXTR
G11	VSS_92	U11	NP
G12	VSS_102	U12	MIPI_CSI_EXTR
G13	VSS_7	U13	MIPI_CSI_AVDD_1V0
G14	VSS_10	U14	GPIO2_C1/CIF_D7/I2S_SDI
G15	CORE_VDD_4	U15	GPIO2_C5/CIF_D2/I2S_MCLK
G16	GPIO1_B7/LCDC_D12/I2S_SDIO2/GMAC_RXDV	U16	GPIO2_C4/CIF_D1/I2S_SCLK
G17	GPIO1_C5/LCDC_CLK/GMAC_CLK	U17	GPIO3_D4/CIF_D9/FLASH_TRIG_IN
G18	NP	U18	GPIO3_D0/CIF_HREF
G19	GPIO2_B4/FLASH_RDY/EMMC_CMD/SFC_CSNO	U19	GPIO1_C7/CIF_D5/I2S_SDIO2
G20	GPIO2_A4/FLASH_D4/EMMC_D4	U20	GPIO3_B0
H1	NP	V1	GPIO0_A6/PMU_DEBUG0
H2	DDR_DQS1	V2	GPIO0_A5/CLK_WIFI_OUT
H3	DDR_DQS1N	V3	HDMI_AVDD_1V8
H4	DDR_DQ13	V4	VSS_78
H5	NP	V5	HDMI_AVDD_1V0
H6	DDR_VDD_2	V6	VSS_79
H7	VSS_91	V7	MIPI_DSI_AVDD_1V0
H8	VSS_14	V8	VSS_80
H9	VSS_15	V9	NP
H10	VSS_16	V10	VSS_81
H11	VSS_17	V11	USB0_ID
H12	VSS_18	V12	USB_VBUS
H13	VSS_19	V13	VSS_82
H14	VSS_20	V14	GPIO2_C6/CIF_D3/I2S_SDIO1
H15	VSS_105	V15	VSS_83
H16	GPIO1_VDD	V16	GPIO2_C3/CIF_D0/I2S_SDO
H17	GPIO2_C2/FLASH_WP/EMMC_PWR/	V17	VSS_84
H18	GPIO2_B0/FLASH_ALE	V18	GPIO3_D2/CIF_CLKOUT
H19	GPIO2_A3/FLASH_D3/EMMC_D3/SFC_HOLD_IO3	V19	GPIO3_C6/CIF_VSYNC
H20	GPIO2_A7/FLASH_D7/EMMC_D7	V20	GPIO1_C6/CIF_D4//I2S_LRCLKTX
J1	NP	W1	HDMI_TXCP
J2	NP	W2	HDMI_TX0N
J3	DDR_DQS0	W3	HDMI_TX0P

Pin Number	Pin Name	Pin Number	Pin Name
J4	DDR_DQ9	W4	HDMI_TX1N
J5	VSS_73	W5	HDMI_TX2P
J6	DDR_VDD_1	W6	VDAC_EXTR
J7	CORE_VDD_7	W7	GPIO1_B1/LCDC_D9/MIPI_D3N/PWM7
J8	VSS_22	W8	GPIO1_A7/LCDC_D7/MIPI_D2N/PWM5
J9	VSS_23	W9	GPIO1_A1/LCDC_D1/MIPI_CLKN
J10	VSS_24	W10	GPIO1_A4/LCDC_D4/MIPI_D1P
J11	VSS_25	W11	GPIO1_A2/LCDC_D2/MIPI_D0P
J12	VSS_26	W12	USB0_DP
J13	VSS_27	W13	USB1_DP
J14	VSS_103	W14	MIPI_CSI_D0N
J15	CORE_VDD_3	W15	MIPI_CSI_D1N
J16	GPIO2_A1/FLASH_D1/EMMC_D1/SFC_SIO_IO1	W16	MIPI_CSI_CLKP
J17	NP	W17	MIPI_CSI_D2N
J18	GPIO2_B7/FLASH_CS1/SFC_CLK	W18	MIPI_CSI_D3P
J19	GPIO2_A5/FLASH_D5/EMMC_D5	W19	VSS_3
J20	GPIO2_B5/FLASH_CS0/	W20	GPIO3_D6/CIF_D11/PRELIGHT_TRIG_OUT
K1	VSS_99	Y1	HDMI_TXCN
K2	DDR_DQ8	Y2	VSS_77
K3	VSS_4	Y3	NP
K4	DDR_DQS0N	Y4	HDMI_TX1P
K5	DDR_DQ12	Y5	HDMI_TX2N
K6	NP	Y6	VDAC_OUT
K7	VSS_29	Y7	GPIO1_B0/LCDC_D8/MIPI_D3P/PWM6
K8	VSS_30	Y8	GPIO1_A6/LCDC_D6/MIPI_D2P
K9	VSS_31	Y9	GPIO1_A0/LCDC_D0/MIPI_CLKP
K10	VSS_32	Y10	GPIO1_A5/LCDC_D5/MIPI_D1N
K11	VSS_33	Y11	GPIO1_A3/LCDC_D3/MIPI_D0N
K12	VSS_34	Y12	USB0_DM
K13	VSS_35	Y13	USB1_DM
K14	VSS_36	Y14	MIPI_CSI_D0P
K15	VSS_106	Y15	MIPI_CSI_D1P
K16	GPIO6_VDD	Y16	MIPI_CSI_CLKN
K17	GPIO2_A2/FLASH_D2/EMMC_D2/SFC_WP_IO2	Y17	MIPI_CSI_D2P
K18	GPIO2_A0/FLASH_D0/EMMC_D0/SFC_SIO_IO0	Y18	MIPI_CSI_D3N
K19	GPIO2_B2/FLASH_WRN	Y19	GPIO2_C0/CIF_D6/I2S_LRCLKRX
K20	GPIO2_B6/EMMC_CLKO/	Y20	GPIO3_D3/CIF_D8/I2S_SDIO3

Table 2-2 RK1108B BGA359 Pin Number Order Information

Pin Number	Pin Name	Pin Number	Pin Name
A1	VSS_1	L1	VSS_131
A2	VSS_107	L2	VSS_132
A3	VSS_108	L3	VSS_133

Pin Number	Pin Name	Pin Number	Pin Name
A4	VSS_89	L4	VSS_120
A5	DDR_VDD_15	L5	VSS_13
A6	VSS_115	L6	NP
A7	NP	L7	VSS_5
A8	NP	L8	VSS_38
A9	VSS_95	L9	VSS_39
A10	DDR_VDD_23	L10	VSS_40
A11	NP	L11	VSS_41
A12	GPIO3_C2/SDMMC0_D0/UART2_TX	L12	VSS_42
A13	GPIO3_C5/SDMMC0_PWR	L13	VSS_43
A14	VIDEO_INP	L14	VSS_28
A15	CODEC_AOL	L15	CORE_VDD_6
A16	CODEC_AOR	L16	GPIO2_A6/FLASH_D6/EMMC_D6
A17	CODEC_MICBIAS	L17	GPIO2_B3/FLASH_RDN
A18	GPIO1_D0/UART0_CTSN/SPI_CLK/DSP_TCK	L18	NP
A19	GPIO1_D1/UART0_RTSN/SPI_CSN0/DSP_TMS	L19	GPIO2_D7/SDIO_D0
A20	GPIO1_D7/HDMI_CEC/DSP_RTCK	L20	GPIO2_D6/SDIO_CMD
B1	VSS_109	M1	NP
B2	VSS_110	M2	VSS_134
B3	VSS_111	M3	GPIO0_A7/SPI_TXD
B4	VSS_112	M4	GPIO0_C0/PWM3/IR
B5	DDR_VDD_16	M5	GPIO0_B7/TSADC_SHUT
B6	VSS_113	M6	PLL_AVDD_1V0
B7	VSS_114	M7	VSS_45
B8	VSS_98	M8	VSS_46
B9	VSS_116	M9	VSS_47
B10	DDR_VDD_24	M10	VSS_48
B11	SADC_AVDD_1V8	M11	VSS_49
B12	GPIO3_C3/SDMMC0_CLKO	M12	VSS_50
B13	GPIO3_C4/SDMMC0_CMD	M13	VSS_51
B14	VIDEO_INN	M14	VSS_52
B15	CODEC_MICR	M15	VSS_70
B16	CODEC_VCM	M16	VSS_104
B17	VSS_6	M17	GPIO3_A2/SDIO_D3
B18	GPIO1_D3/UART0_TX/SPI_TXD/D	M18	GPIO3_A0/SDIO_D1
B19	VSS_2	M19	GPIO2_D5/SDIO_CLKO
B20	GPIO1_B3/LCDC_D16/I2S_SCLK/GMAC_TXD1	M20	GPIO3_A1/SDIO_D2
C1	NP	N1	GPIO0_B6/I2C3_SCL
C2	DDR_VDD_12	N2	VSS_74
C3	DDR_VDD_13	N3	EFUSE
C4	VSS_97	N4	NP
C5	DDR_VDD_17	N5	GPIO0_B5/PMIC_SLEEP
C6	VSS_90	N6	PLL_AVDD_1V8

Pin Number	Pin Name	Pin Number	Pin Name
C7	VSS_96	N7	VSS_53
C8	DDR_VDD_22	N8	VSS_54
C9	VSS_17	N9	VSS_55
C10	NP	N10	VSS_56
C11	VSS_72	N11	VSS_57
C12	GPIO3_C0/SDMMC0_D2	N12	VSS_58
C13	NP	N13	VSS_59
C14	VIDEO_AVDD_1V8	N14	VSS_12
C15	CODEC_MICL	N15	CORE_VDD_5
C16	NP	N16	GPIO3_B1/PCM_OUT/FLASH_TRIG_OUT
C17	5VGPIO1_D5/UART2_RTSN/HDMI_I2C0_SDA	N17	NP
C18	5VGPIO1_D6/HDMI_HPD0	N18	GPIO3_B2/PCM_IN/FLASH_TRIG_IN
C19	GPIO1_B4/LCDC_D15/I2S_MCLK/GMAC_TXEN	N19	GPIO3_B6
C20	GPIO1_B6/LCDC_D13/I2S_LRCLKTX/GMAC_RXD1	N20	GPIO3_B4/PCM_SYNC/PRELIGHT_TRIG_OUT
D1	NP	P1	XIN_24M
D2	VSS_88	P2	XOUT24M
D3	DDR_VDD_14	P3	VSS_61
D4	NP	P4	GPIO0_A3/SPI_CLK
D5	DDR_VDD_18	P5	GPIO0_A4/SPI_CSN0
D6	DDR_VDD_19	P6	GPIO0_C3/PMU_DEBUG2
D7	DDR_VDD_20	P7	TEST
D8	DDR_VDD_21	P8	VSS_62
D9	NP	P9	VSS_63
D10	ADC_IN3	P10	VSS_64
D11	GPIO3_B7/SDMMC0_D3	P11	VSS_65
D12	GPIO3_C1/SDMMC0_D1/UART2_RX	P12	VSS_66
D13	ADC_IN0	P13	VSS_67
D14	VSS_69	P14	VSS_68
D15	CODEC_AVDD_1V8	P15	NP
D16	VSS_60	P16	GPIO5_VDD
D17	NP	P17	GPIO3_A6/UART1_TX
D18	NP	P18	GPIO3_A4/UART1_CTSN
D19	GPIO1_D2/UART0_RXSPI_RXD/D	P19	GPIO3_A7
D20	GPIO1_C2/LCDC_DEN/I2S_SDIO3/GMAC_RXER	P20	GPIO3_B5/MIPI_CSI_MCLK
E1	VSS_85	R1	NP
E2	VSS_122	R2	GPIO0_B3
E3	VSS_123	R3	GPIO0_C6/PWM2/PMU_DEBUG4
E4	PZQ	R4	GPIO0_B2/I2C0_SDA
E5	VSS_100	R5	NP
E6	DDR_VDD_25	R6	PMU_DVDD_1V0
E7	DDR_VDD_26	R7	CORE_VDD_8
E8	DDR_VDD_27	R8	PMUIO_VDD
E9	VSS_93	R9	VSS_71

Pin Number	Pin Name	Pin Number	Pin Name
E10	DDR_VDD_4	R10	VSS_44
E11	ADC_IN5	R11	VSS_101
E12	ADC_IN2	R12	VSS_9
E13	ADC_IN1	R13	VSS_75
E14	VIDEO_AVDD_1V0	R14	VSS_76
E15	CODEC_AVSS	R15	VSS_94
E16	GPIO2_D2/UART2_TX/JTAG_TCK	R16	GPIO3_D5/CIF_D10/FLASH_TRIG_OUT
E17	5VGPIO1_D4/UART2_CTSN/HDMI_I2C0_SCL	R17	GPIO2_D4/I2C1_SCL
E18	GPIO1_C0/LCDC_D11/I2S_LRCLKRX	R18	NP
E19	GPIO1_C1/LCDC_D10/I2S_SDI/PWM4	R19	GPIO3_B3/PCM_CLK
E20	GPIO1_C3/LCDC_VSYNC/GMAC_MDIO	R20	GPIO3_A3/UART1_RTSN
F1	DDR_121	T1	NPOR
F2	VSS_87	T2	GPIO0_C5/PWM0/PMU_DEBUG3
F3	VSS_124	T3	GPIO0_C4/PWM1/I2C3_SDA
F4	VSS_125	T4	GPIO0_B1/I2C0_SCL
F5	VSS_126	T5	GPIO0_B4
F6	VREF	T6	NP
F7	DDR_VDD_5	T7	GPIO0_A1/SDMMC0_DET
F8	DDR_VDD_6	T8	NP
F9	DDR_VDD_7	T9	NP
F10	VSS_11	T10	USB_AVDD_1V8
F11	NP	T11	USB_AVDD_3V3
F12	ADC_IN4	T12	USB_VDD_1V0
F13	NP	T13	NP
F14	APIO3_VDD	T14	VSS_21
F15	NP	T15	NP
F16	GPIO2_D1/UART2_RX/JTAG_TMS	T16	APIO2_VDD
F17	GPIO1_B2/LCDC_D17/I2S_SDO/GMAC_TXD0	T17	GPIO3_D1/CIF_PDN
F18	GPIO1_B5/LCDC_D14/I2S_SDIO1/GMAC_RXD0	T18	GPIO3_C7/CIF_CLKIN
F19	GPIO1_C4/LCDC_HSYNC/GMAC_MDC	T19	GPIO2_D3/I2C1_SDA
F20	GPIO2_B1/FLASH_CLE	T20	GPIO3_A5/UART1_RX
G1	VSS_118	U1	GPIO0_A2/SDMMC1_PWR
G2	VSS_119	U2	GPIO0_C2/PMU_DEBUG1
G3	VSS_86	U3	GPIO0_C1/HDMI_HPD1/CVBS_CLK_IN
G4	NP	U4	NP
G5	DDR_VDD_11	U5	GPIO0_B0/SPI_RXD
G6	DDR_VDD_3	U6	HDMI_EXTR
G7	VSS_37	U7	VDAC_AVDD_1V8
G8	CORE_VDD_1	U8	MIPI_DSI_AVDD_1V8
G9	CORE_VDD_2	U9	MIPI_DSI_AVDD_3V3
G10	VSS_8	U10	USB_EXTR
G11	VSS_92	U11	NP
G12	VSS_102	U12	MIPI_CSI_EXTR

Pin Number	Pin Name	Pin Number	Pin Name
G13	VSS_7	U13	MIPI_CSI_AVDD_1V0
G14	VSS_10	U14	GPIO2_C1/CIF_D7/I2S_SDI
G15	CORE_VDD_4	U15	GPIO2_C5/CIF_D2/I2S_MCLK
G16	GPIO1_B7/LCDC_D12/I2S_SDIO2/GMAC_RXDV	U16	GPIO2_C4/CIF_D1/I2S_SCLK
G17	GPIO1_C5/LCDC_CLK/GMAC_CLK	U17	GPIO3_D4/CIF_D9/FLASH_TRIG_IN
G18	NP	U18	GPIO3_D0/CIF_HREF
G19	GPIO2_B4/FLASH_RDY/EMMC_CMD/SFC_CSN0	U19	GPIO1_C7/CIF_D5/I2S_SDIO2
G20	GPIO2_A4/FLASH_D4/EMMC_D4	U20	GPIO3_B0
H1	NP	V1	GPIO0_A6/PMU_DEBUG0
H2	DDR_VDD_8	V2	GPIO0_A5/CLK_WIFI_OUT
H3	DDR_VDD_9	V3	HDMI_AVDD_1V8
H4	DDR_VDD_10	V4	VSS_78
H5	NP	V5	HDMI_AVDD_1V0
H6	DDR_VDD_2	V6	VSS_79
H7	VSS_91	V7	MIPI_DSI_AVDD_1V0
H8	VSS_14	V8	VSS_80
H9	VSS_15	V9	NP
H10	VSS_16	V10	VSS_81
H11	VSS_17	V11	USB0_ID
H12	VSS_18	V12	USB_VBUS
H13	VSS_19	V13	VSS_82
H14	VSS_20	V14	GPIO2_C6/CIF_D3/I2S_SDIO1
H15	VSS_105	V15	VSS_83
H16	APIO1_VDD	V16	GPIO2_C3/CIF_D0/I2S_SDO
H17	GPIO2_C2/FLASH_WP/EMMC_PWR/	V17	VSS_84
H18	GPIO2_B0/FLASH_ALE	V18	GPIO3_D2/CIF_CLKOUT
H19	GPIO2_A3/FLASH_D3/EMMC_D3/SFC_HOLD_IO3	V19	GPIO3_C6/CIF_VSYNC
H20	GPIO2_A7/FLASH_D7/EMMC_D7	V20	GPIO1_C6/CIF_D4//I2S_LRCLKTX
J1	NP	W1	HDMI_TXCP
J2	NP	W2	HDMI_TX0N
J3	VSS_127	W3	HDMI_TX0P
J4	VSS_128	W4	HDMI_TX1N
J5	VSS_73	W5	HDMI_TX2P
J6	DDR_VDD_1	W6	VDAC_EXTR
J7	CORE_VDD_7	W7	GPIO1_B1/LCDC_D9/MIPI_D3N/PWM7
J8	VSS_22	W8	GPIO1_A7/LCDC_D7/MIPI_D2N/PWM5
J9	VSS_23	W9	GPIO1_A1/LCDC_D1/MIPI_CLKN
J10	VSS_24	W10	GPIO1_A4/LCDC_D4/MIPI_D1P
J11	VSS_25	W11	GPIO1_A2/LCDC_D2/MIPI_D0P
J12	VSS_26	W12	USB0_DP
J13	VSS_27	W13	USB1_DP
J14	VSS_103	W14	MIPI_CSI_D0N
J15	CORE_VDD_3	W15	MIPI_CSI_D1N

Pin Number	Pin Name	Pin Number	Pin Name
J16	GPIO2_A1/FLASH_D1/EMMC_D1/SFC_SIO_IO1	W16	MIPI_CSI_CLKP
J17	NP	W17	MIPI_CSI_D2N
J18	GPIO2_B7/FLASH_CS1/SFC_CLK	W18	MIPI_CSI_D3P
J19	GPIO2_A5/FLASH_D5/EMMC_D5	W19	VSS_3
J20	GPIO2_B5/FLASH_CS0/	W20	GPIO3_D6/CIF_D11/PRELIGHT_TRIG_OUT
K1	VSS_99	Y1	HDMI_TXCN
K2	VSS_129	Y2	VSS_77
K3	VSS_4	Y3	NP
K4	VSS_130	Y4	HDMI_TX1P
K5	VSS_135	Y5	HDMI_TX2N
K6	NP	Y6	VDAC_OUT
K7	VSS_29	Y7	GPIO1_B0/LCDC_D8/MIPI_D3P/PWM6
K8	VSS_30	Y8	GPIO1_A6/LCDC_D6/MIPI_D2P
K9	VSS_31	Y9	GPIO1_A0/LCDC_D0/MIPI_CLKP
K10	VSS_32	Y10	GPIO1_A5/LCDC_D5/MIPI_D1N
K11	VSS_33	Y11	GPIO1_A3/LCDC_D3/MIPI_D0N
K12	VSS_34	Y12	USB0_DM
K13	VSS_35	Y13	USB1_DM
K14	VSS_36	Y14	MIPI_CSI_D0P
K15	VSS_106	Y15	MIPI_CSI_D1P
K16	APIO6_VDD	Y16	MIPI_CSI_CLKN
K17	GPIO2_A2/FLASH_D2/EMMC_D2/SFC_WP_IO2	Y17	MIPI_CSI_D2P
K18	GPIO2_A0/FLASH_D0/EMMC_D0/SFC_SIO_IO0	Y18	MIPI_CSI_D3N
K19	GPIO2_B2/FLASH_WRN	Y19	GPIO2_C0/CIF_D6/I2S_LRCLKRX
K20	GPIO2_B6/EMMC_CLKO/	Y20	GPIO3_D3/CIF_D8/I2S_SDIO3

2.6 RK1108 Power/ground IO descriptions

Table 2-3 RK1108A Power/Ground IO information

Group	Ball#	Descriptions
-------	-------	--------------

Group	Ball#	Descriptions
GND	A1,A4,A9 B8,B17,B19 C4,C6,C7,C11 D2,D14,D16 E1,E5,E9, F2,F10 G3,G7,G10,G11,G12,G13,G14 H7,H8,H9,H10,H11,H12,H13,H14,H15 J5,J8,J9,J10,J11,J12,J13,J14 K1,K3,K7,K8,K9,K10,K11,K12,K13,K14,K15 L5,L7,L8,L9,L10,L11,L12,L13,L14 M7,M8,M9,M10,M11,M12,M13,M14,M15,M16 N2,N7,N8,N9,N10,N11,N12,N13,N14 P3,P8,P9,P10,P11,P12,P13,P14 R9,R10,R11,R12,R13,R14,R15 T14,V4,V6,V8,V10,V13,V15,V17,W19,Y2	Internal Core Ground Digital IO Ground
CODEC_AVSS	E15	Analog Codec Ground
PLL_AVDD_1V8	N6	PLL IO Power
PLL_AVDD_1V0	M6	General PLL Analog Power
CORE_VDD	G8,G9,J15,G15,N15,L15,J7,R7	ARM Core Power
PMU_DVDD_1V0	R6	PMU IO Domain(PowerDomain) Power
PMUIO_VDD	R8	PMU IO Power
APIO1_VDD	H16	APIO1 PowerDomain Power
APIO2_VDD	T16	APIO2 PowerDomain Power
APIO3_VDD	F14	APIO3 PowerDomain Power
APIO5_VDD	P16	APIO5 PowerDomain Power
APIO6_VDD	K16	APIO6 PowerDomain Power
DDR_VDD	J6,H6,G6,E10,F7,F8,F9	DDR PHY Power
USB_VDD_1V0	T12	USB OTG2.0/Host2.0 Digital Power
USB_AVDD_1V8	T10	USB OTG2.0/Host2.0 Analog Power
USB_AVDD_3V3	T11	USB OTG2.0/Host2.0 Analog Power
MIPI_CSI_AVDD_1V0	U13	MIPI_CSI PHY Analog Power
MIPI_DSI_AVDD_1V0	V7	MIPI_DSI PHY Analog Power
MIPI_DSI_AVDD_1V8	U8	MIPI_DSI PHY Analog Power
MIPI_DSI_AVDD_3V3	U9	MIPI_DSI PHY Analog Power
HDMI_AVDD_1V8	V3	HDMI PHY Analog Power
HDMI_AVDD_1V0	V5	HDMI PHY Analog Power
SADC_AVDD_1V8	B11	SADC Analog Power
CODEC_AVDD_1V8	D15	Audio Codec Analog Power
VDAC_AVDD_1V8	U7	VDAC Analog Power
VIDEO_AVDD_1V0	E14	VIDEO Analog Power
VIDEO_AVDD_1V8	C14	VIDEO Analog Power

Table 2-4 RK1108B Power/Ground IO information

Group	Ball #	Descriptions
GND	A1,A2,A3,A4,A6,A9 B1,B2,B3,B4,B6,B7,B8,B9,B17,B19 C4,C6,C7,C9,C11 D2,D14,D16 E1,E2,E3,E4,E5,E9,E10 F1,F2,F3,F4,F5,F6,F10 G1,G2,G3,G7,G10,G11,G12,G13,G14 H7,H8,H9,H10,H11,H12,H13,H14,H15 J3,J4,J5,J8,J9,J10,J11,J12,J13,J14 K1,K2,K3,K4,K5,K7,K8,K9,K10,K11,K12,K13,K14,K15 L1,L2,L3,L4,L5,L7,L8,L9,L10,L11,L12,L13,L14 M2,M7,M8,M9,M10,M11,M12,M13,M14,M15,M16 N2,N7,N8,N9,N10,N11,N12,N13,N14 P3,P8,P9,P10,P11,P12,P13,P14 R9,R10,R11,R12,R13,R14,R15 T14,V4,V6,V8,V10,V13,V15,V17,W19,Y2	Internal Core Ground Digital IO Ground
CODEC_AVSS	E15	Analog Codec Ground
PLL_AVDD_1V8	N6	PLL IO Power
PLL_AVDD_1V0	M6	General PLL Analog Power
CORE_VDD	G8,G9,J15,G15,N15,L15,J7,R7	ARM Core Power
PMU_DVDD_1V0	R6	PMU IO Domain(PowerDomain) Power
PMUIO_VDD	R8	PMU IO Power
APIO1_VDD	H16	APIO1 PowerDomain Power
APIO2_VDD	T16	APIO2 PowerDomain Power
APIO3_VDD	F14	APIO3 PowerDomain Power
APIO5_VDD	P16	APIO5 PowerDomain Power
APIO6_VDD	K16	APIO6 PowerDomain Power
DDR_VDD	A5,A10,B5,B10,C2,C3,C5,C8,D3,D6,D7,D8,E6,E7,G5,J6,H6,G6,E10,F7,F8,F9,H2,H3,H4	DDR PHY Power
USB_VDD_1V0	T12	USB

Group	Ball#	Descriptions
		OTG2.0/Host2.0 Digital Power
USB_AVDD_1V8	T10	USB OTG2.0/Host2.0 Analog Power
USB_AVDD_3V3	T11	USB OTG2.0/Host2.0 Analog Power
MIPI_CSI_AVDD_1V0	U13	MIPI_CSI PHY Analog Power
MIPI_DSI_AVDD_1V0	V7	MIPI_DSI PHY Analog Power
MIPI_DSI_AVDD_1V8	U8	MIPI_DSI PHY Analog Power
MIPI_DSI_AVDD_3V3	U9	MIPI_DSI PHY Analog Power
HDMI_AVDD_1V8	V3	HDMI PHY Analog Power
HDMI_AVDD_1V0	V5	HDMI PHY Analog Power
SADC_AVDD_1V8	B11	SADC Analog Power
CODEC_AVDD_1V8	D15	Audio Codec Analog Power
VDAC_AVDD_1V8	U7	VDAC Analog Power
VIDEO_AVDD_1V0	E14	VIDEO Analog Power
VIDEO_AVDD_1V8	C14	VIDEO Analog Power

2.7 RK1108 Function IO description

Table 2-5 RK1108A function IO description

Pin	Pin Name	Func1	Func2	Func3	Func4	Pad Type	De f®	Pull	Drive Strengt h®	IN T®	DIE Power domain
T7	GPIO0_A1/SDMMC0_DET	GPIO0_A1	SDMMC0_DE T			I/O	I	up	4	✓	PMUIO IO Voltage 3.3V
U1	GPIO0_A2/SDMMC1_PWR	GPIO0_A2	SDMMC1_PW R			I/O	I	down	4	✓	
P4	GPIO0_A3/SPI_CLK	GPIO0_A3	SPI_CLK			I/O	I	down	4	✓	
P5	GPIO0_A4/SPI_CSN0	GPIO0_A4	SPI_CSN0			I/O	I	down	4	✓	
V2	GPIO0_A5/CLK_WIFI_OUT	GPIO0_A5	CLK_WIFI_O UT			I/O	I	up	4	✓	
V1	GPIO0_A6/PMU_DEBUG0	GPIO0_A6	PMU_DEBUG0			I/O	I	down	4	✓	
M3	GPIO0_A7/SPI_TXD	GPIO0_A7	SPI_TXD			I/O	I	down	4	✓	
U5	GPIO0_B0/SPI_RXD	GPIO0_B0	SPI_RXD			I/O	I	down	4	✓	
T4	GPIO0_B1/I2C0_SCL	GPIO0_B1	I2C0_SCL			I/O	I	up	4	✓	
R4	GPIO0_B2/I2C0_SDA	GPIO0_B2	I2C0_SDA			I/O	I	up	4	✓	
R2	GPIO0_B3	GPIO0_B3				I/O	I	up	4	✓	
T5	GPIO0_B4	GPIO0_B4				I/O	I	up	4	✓	
N5	GPIO0_B5/PMIC_SLEEP	GPIO0_B5	PMIC_SLEEP			I/O	I	down	4	✓	
N1	GPIO0_B6/I2C3_SCL	GPIO0_B6	I2C3_SCL			I/O	I	up	4	✓	
M5	GPIO0_B7/TSADC_SHUT	GPIO0_B7	TSADC_SHUT			I/O	I	up	4	✓	
M4	GPIO0_C0/PWM3/IR	GPIO0_C0	PWM3	IR		I/O	I	down	4	✓	
U3	GPIO0_C1/HDMI_HPD1/CVBS_CLK_IN	GPIO0_C1	HDMI_HPD1	CVBS_CLK _IN		I/O	I	down	4	✓	
U2	GPIO0_C2/PMU_DEBUG1	GPIO0_C2	PMU_DEBUG1			I/O	I	down	4	✓	
P6	GPIO0_C3/PMU_DEBUG2	GPIO0_C3	PMU_DEBUG2			I/O	I	down	4	✓	
T3	GPIO0_C4/PWM1/I2C3_SDA	GPIO0_C4	PWM1	I2C3_SDA		I/O	I	up	4	✓	
T2	GPIO0_C5/PWM0/PMU_DEBUG3	GPIO0_C5	PWM0	PMU_DEBU G3		I/O	I	down	4	✓	
R3	GPIO0_C6/PWM2/PMU_DEBUG4	GPIO0_C6	PWM2	PMU_DEBU G4		I/O	I	down	4	✓	
Y9	GPIO1_A0/LCDC_D0/MIPI_CLKP	GPIO1_A0	LCDC_D0	MIPI_CLKP		A		NA		✓	MIPI_DSI
W9	GPIO1_A1/LCDC_D1/MIPI_CLKN	GPIO1_A1	LCDC_D1	MIPI_CLKN		A		NA		✓	
W11	GPIO1_A2/LCDC_D2/MIPI_D0P	GPIO1_A2	LCDC_D2	MIPI_D0P		A		NA		✓	
Y11	GPIO1_A3/LCDC_D3/MIPI_D0N	GPIO1_A3	LCDC_D3	MIPI_D0N		A		NA		✓	
W10	GPIO1_A4/LCDC_D4/MIPI_D1P	GPIO1_A4	LCDC_D4	MIPI_D1P		A		NA		✓	
Y10	GPIO1_A5/LCDC_D5/MIPI_D1N	GPIO1_A5	LCDC_D5	MIPI_D1N		A		NA		✓	
Y8	GPIO1_A6/LCDC_D6/MIPI_D2P	GPIO1_A6	LCDC_D6	MIPI_D2P		A		NA		✓	
W8	GPIO1_A7/LCDC_D7/MIPI_D2N/PW M5	GPIO1_A7	LCDC_D7	MIPI_D2N	PWM5	A		NA		✓	
Y7	GPIO1_B0/LCDC_D8/MIPI_D3P/PW M6	GPIO1_B0	LCDC_D8	MIPI_D3P	PWM6	A		NA		✓	
W7	GPIO1_B1/LCDC_D9/MIPI_D3N/PW M7	GPIO1_B1	LCDC_D9	MIPI_D3N	PWM7	A		NA		✓	
F17	GPIO1_B2/LCDC_D17/I2S_SDO/GM	GPIO1_B2	LCDC_D17	I2S_SDO	GMAC_T	I/O	I	down	8	✓	APIO1

Pin	Pin Name	Func1	Func2	Func3	Func4	Pad Type	De f [®]	Pull	Drive Strengt h [®]	IN T [®]	DIE Power domain
	AC_TXD0				XD0						IO Voltage 3.3V
B20	GPIO1_B3/LCDC_D16/I2S_SCLK/GM AC_TXD1	GPIO1_B3	LCDC_D16	I2S_SCLK	GMAC_T XD1	I/O	I	down	8	✓	
C19	GPIO1_B4/LCDC_D15/I2S_MCLK/G MAC_TXEN	GPIO1_B4	LCDC_D15	I2S_MCLK	GMAC_T XEN	I/O	I	down	8	✓	
F18	GPIO1_B5/LCDC_D14/I2S_SDIO1/G MAC_RXD0	GPIO1_B5	LCDC_D14	I2S_SDIO1	GMAC_R XD0	I/O	I	down	8	✓	
C20	GPIO1_B6/LCDC_D13/I2S_LRCLKTX /GMAC_RXD1	GPIO1_B6	LCDC_D13	I2S_LRCLK TX	GMAC_R XD1	I/O	I	down	8	✓	
G16	GPIO1_B7/LCDC_D12/I2S_SDIO2/G MAC_RXDV	GPIO1_B7	LCDC_D12	I2S_SDIO2	GMAC_R XDV	I/O	I	down	8	✓	
E18	GPIO1_C0/LCDC_D11/I2S_LRCLKRX	GPIO1_C0	LCDC_D11	I2S_LRCLK RX		I/O	I	down	8	✓	
E19	GPIO1_C1/LCDC_D10/I2S_SDI/PWM 4	GPIO1_C1	LCDC_D10	I2S_SDI	PWM4	I/O	I	down	8	✓	
D20	GPIO1_C2/LCDC_DEN/I2S_SDIO3/G MAC_RXER	GPIO1_C2	LCDC_DEN	I2S_SDIO3	GMAC_R XER	I/O	I	down	8	✓	
E20	GPIO1_C3/LCDC_VSYNC/GMAC_MDI O	GPIO1_C3	LCDC_VSYNC	GMAC_MDI O		I/O	I	down	8	✓	
F19	GPIO1_C4/LCDC_HSYNC/GMAC_MD C	GPIO1_C4	LCDC_HSYNC	GMAC_MD C		I/O	I	down	8	✓	
G17	GPIO1_C5/LCDC_CLK/GMAC_CLK	GPIO1_C5	LCDC_CLK	GMAC_CLK		I/O	I	down	8	✓	
A18	GPIO1_D0/UART0_CTSN/SPI_CLK/D SP_TCK	GPIO1_D0	UART0_CTSN	SPI_CLK	DSP_TC K	I/O	I	down	4	✓	
A19	GPIO1_D1/UART0_RTSN/SPI_CSN0/ DSP_TMS	GPIO1_D1	UART0_RTSN	SPI_CSN0	DSP_TM S	I/O	I	up	4	✓	
D19	GPIO1_D2/UART0_RXSPI_RXD/D	GPIO1_D2	UART0_RX	SPI_RXD		I/O	I	up	4	✓	
B18	GPIO1_D3/UART0_TX/SPI_TXD/D	GPIO1_D3	UART0_TX	SPI_TXD		I/O	I	down	4	✓	
E17	5VGPIO1_D4/UART2_CTSN/HDMI_I 2C0_SCL	5VGPIO1_D4	UART2_CTSN	HDMI_I2C 0_SCL		I/O	I	up	4	✓	
C17	5VGPIO1_D5/UART2_RTSN/HDMI_I 2C0_SDA	5VGPIO1_D5	UART2_RTSN	HDMI_I2C 0_SDA		I/O	I	up	4	✓	
C18	5VGPIO1_D6/HDMI_HPD0	5VGPIO1_D6	HDMI_HPD0			I/O	I	down	4	✓	
A20	GPIO1_D7/HDMI_CEC/DSP_RTCK	GPIO1_D7	HDMI_CEC	DSP_RTCK		I/O	I	up	4	✓	
F16	GPIO2_D1/UART2_RX/JTAG_TMS	GPIO2_D1	UART2_RX	JTAG_TMS		I/O	I	up	4	✓	
E16	GPIO2_D2/UART2_TX/JTAG_TCK	GPIO2_D2	UART2_TX	JTAG_TCK		I/O	I	up	4	✓	
T19	GPIO2_D3/I2C1_SDA	GPIO2_D3	I2C1_SDA			I/O	I	up	4	✓	
R17	GPIO2_D4/I2C1_SCL	GPIO2_D4	I2C1_SCL			I/O	I	up	4	✓	
M19	GPIO2_D5/SDIO_CLKO	GPIO2_D5	SDIO_CLKO			I/O	I	down	4	✓	
L20	GPIO2_D6/SDIO_CMD	GPIO2_D6	SDIO_CMD			I/O	I	up	8	✓	
L19	GPIO2_D7/SDIO_D0	GPIO2_D7	SDIO_D0			I/O	I	up	8	✓	
M18	GPIO3_A0/SDIO_D1	GPIO3_A0	SDIO_D1			I/O	I	up	8	✓	
M20	GPIO3_A1/SDIO_D2	GPIO3_A1	SDIO_D2			I/O	I	up	8	✓	

Pin	Pin Name	Func1	Func2	Func3	Func4	Pad Type	Def [®]	Pull	Drive Strength [®]	IN T [®]	DIE Power domain
M17	GPIO3_A2/SDIO_D3	GPIO3_A2	SDIO_D3			I/O	I	up	8	✓	
R20	GPIO3_A3/UART1_RTSN	GPIO3_A3	UART1_RTSN			I/O	I	up	4	✓	
P18	GPIO3_A4/UART1_CTSN	GPIO3_A4	UART1_CTSN			I/O	I	up	4	✓	
T20	GPIO3_A5/UART1_RX	GPIO3_A5	UART1_RX			I/O	I	up	4	✓	
P17	GPIO3_A6/UART1_TX	GPIO3_A6	UART1_TX			I/O	I	up	4	✓	
P19	GPIO3_A7	GPIO3_A7				I/O	I	down	4	✓	
U20	GPIO3_B0	GPIO3_B0				I/O	I	down	4	✓	
N16	GPIO3_B1/PCM_OUT/FLASH_TRIG_OUT	GPIO3_B1	PCM_OUT	FLASH_TRIG_OUT		I/O	I	down	4	✓	
N18	GPIO3_B2/PCM_IN/FLASH_TRIG_IN	GPIO3_B2	PCM_IN	FLASH_TRIG_IN		I/O	I	down	4	✓	
R19	GPIO3_B3/PCM_CLK	GPIO3_B3	PCM_CLK			I/O	I	down	4	✓	
N20	GPIO3_B4/PCM_SYNC/PRELIGHT_TRIG_OUT	GPIO3_B4	PCM_SYNC	PRELIGHT_TRIG_OUT		I/O	I	down	4	✓	
P20	GPIO3_B5/MIPI_CSI_MCLK	GPIO3_B5	MIPI_CSI_MCLK			I/O	I	down	4	✓	
N19	GPIO3_B6	GPIO3_B6				I/O	I	down	4	✓	
D11	GPIO3_B7/SDMMC0_D3	GPIO3_B7	SDMMC0_D3			I/O	I	up	8	✓	API03 IO Voltage 3.3V/1.8V
C12	GPIO3_C0/SDMMC0_D2	GPIO3_C0	SDMMC0_D2			I/O	I	up	8	✓	
D12	GPIO3_C1/SDMMC0_D1/UART2_RX	GPIO3_C1	SDMMC0_D1	UART2_RX		I/O	I	up	8	✓	
A12	GPIO3_C2/SDMMC0_D0/UART2_TX	GPIO3_C2	SDMMC0_D0	UART2_TX		I/O	I	up	8	✓	
B12	GPIO3_C3/SDMMC0_CLKO	GPIO3_C3	SDMMC0_CLKO			I/O	I	down	8	✓	
B13	GPIO3_C4/SDMMC0_CMD	GPIO3_C4	SDMMC0_CMD			I/O	I	up	8	✓	
A13	GPIO3_C5/SDMMC0_PWR	GPIO3_C5	SDMMC0_PWR			I/O	I	down	4	✓	
V20	GPIO1_C6/CIF_D4/I2S_LRCLKTX	GPIO1_C6	CIF_D4	I2S_LRCLKTX		I/O	I	down	8	✓	API03 IO Voltage 3.3V/1.8V
U19	GPIO1_C7/CIF_D5/I2S_SDIO2	GPIO1_C7	CIF_D5	I2S_SDIO2		I/O	I	down	8	✓	
Y19	GPIO2_C0/CIF_D6/I2S_LRCLKRX	GPIO2_C0	CIF_D6	I2S_LRCLKRX		I/O	I	down	8	✓	
U14	GPIO2_C1/CIF_D7/I2S_SDI	GPIO2_C1	CIF_D7	I2S_SDI		I/O	I	down	8	✓	
V16	GPIO2_C3/CIF_D0/I2S_SDO	GPIO2_C3	CIF_D0	I2S_SDO		I/O	I	down	8	✓	
U16	GPIO2_C4/CIF_D1/I2S_SCLK	GPIO2_C4	CIF_D1	I2S_SCLK		I/O	I	down	8	✓	
U15	GPIO2_C5/CIF_D2/I2S_MCLK	GPIO2_C5	CIF_D2	I2S_MCLK		I/O	I	down	8	✓	
V14	GPIO2_C6/CIF_D3/I2S_SDIO1	GPIO2_C6	CIF_D3	I2S_SDIO1		I/O	I	down	8	✓	
V19	GPIO3_C6/CIF_VSYNC	GPIO3_C6	CIF_VSYNC			I/O	I	down	8	✓	
T18	GPIO3_C7/CIF_CLKIN	GPIO3_C7	CIF_CLKIN			I/O	I	down	8	✓	
U18	GPIO3_D0/CIF_HREF	GPIO3_D0	CIF_HREF			I/O	I	down	8	✓	
T17	GPIO3_D1/CIF_PDN	GPIO3_D1	TCIF_PDN			I/O	I	down	8	✓	
V18	GPIO3_D2/CIF_CLKOUT	GPIO3_D2	CIF_CLKOUT			I/O	I	down	8	✓	
Y20	GPIO3_D3/CIF_D8/I2S_SDIO3	GPIO3_D3	CIF_D8	I2S_SDIO3		I/O	I	down	8	✓	

Pin	Pin Name	Func1	Func2	Func3	Func4	Pad Type	Def [®]	Pull	Drive Strength [®]	IN T [®]	DIE Power domain
U17	GPIO3_D4/CIF_D9/FLASH_TRIG_IN	GPIO3_D4	CIF_D9	FLASH_TRIG_IN		I/O	I	down	8	✓	
R16	GPIO3_D5/CIF_D10/FLASH_TRIG_OUT	GPIO3_D5	CIF_D10	FLASH_TRIG_OUT		I/O	I	down	8	✓	
W20	GPIO3_D6/CIF_D11/PRELIGHT_TRIG_OUT	GPIO3_D6	CIF_D11	PRELIGHT_TRIG_OUT		I/O	I	down	8	✓	
K18	GPIO2_A0/FLASH_D0/EMMC_D0/SFC_SIO_I00	GPIO2_A0	FLASH_D0	EMMC_D0	SFC_SIO_I00	I/O	I	up	8	✓	APIO6 IO Voltage 3.3V/1.8V
J16	GPIO2_A1/FLASH_D1/EMMC_D1/SFC_SIO_I01	GPIO2_A1	FLASH_D1	EMMC_D1	SFC_SIO_I01	I/O	I	up	8	✓	
K17	GPIO2_A2/FLASH_D2/EMMC_D2/SFC_WP_I02	GPIO2_A2	FLASH_D2	EMMC_D2	SFC_WP_I02	I/O	I	up	8	✓	
H19	GPIO2_A3/FLASH_D3/EMMC_D3/SFC_HOLD_I03	GPIO2_A3	FLASH_D3	EMMC_D3	SFC_HOLD_I03	I/O	I	up	8	✓	
G20	GPIO2_A4/FLASH_D4/EMMC_D4	GPIO2_A4	FLASH_D4	EMMC_D4		I/O	I	up	8	✓	
J19	GPIO2_A5/FLASH_D5/EMMC_D5	GPIO2_A5	FLASH_D5	EMMC_D5		I/O	I	up	8	✓	
L16	GPIO2_A6/FLASH_D6/EMMC_D6	GPIO2_A6	FLASH_D6	EMMC_D6		I/O	I	up	8	✓	
H20	GPIO2_A7/FLASH_D7/EMMC_D7	GPIO2_A7	FLASH_D7	EMMC_D7		I/O	I	up	8	✓	
H18	GPIO2_B0/FLASH_ALE	GPIO2_B0	FLASH_ALE			I/O	I	down	8	✓	
F20	GPIO2_B1/FLASH_CLE	GPIO2_B1	FLASH_CLE			I/O	I	down	8	✓	
K19	GPIO2_B2/FLASH_WRN	GPIO2_B2	FLASH_WRN			I/O	I	up	8	✓	
L17	GPIO2_B3/FLASH_RDN	GPIO2_B3	FLASH_RDN			I/O	I	up	8	✓	
G19	GPIO2_B4/FLASH_RDY/EMMC_CMD/SFC_CSN0	GPIO2_B4	FLASH_RDY	EMMC_CMD	SFC_CSN0	I/O	I	up	8	✓	
J20	GPIO2_B5/FLASH_CS0/	GPIO2_B5	FLASH_CS0			I/O	I	up	8	✓	
K20	GPIO2_B6/EMMC_CLKO/	GPIO2_B6	EMMC_CLKO			I/O	I	down	8	✓	
J18	GPIO2_B7/FLASH_CS1/SFC_CLK	GPIO2_B7	FLASH_CS1	SFC_CLK		I/O	I	up	8	✓	
H17	GPIO2_C2/FLASH_WP/EMMC_PWR/	GPIO2_C2	FLASH_WP	EMMC_PWR		I/O	I	down	8	✓	
W14	MIPI_CSI_D0N	MIPI_CSI_D0N				A		NA			MIPI_CSI
Y14	MIPI_CSI_D0P	MIPI_CSI_D0P				A		NA			
W15	MIPI_CSI_D1N	MIPI_CSI_D1N				A		NA			
Y15	MIPI_CSI_D1P	MIPI_CSI_D1P				A		NA			
W17	MIPI_CSI_D2N	MIPI_CSI_D2N				A		NA			
Y17	MIPI_CSI_D2P	MIPI_CSI_D2P				A		NA			
Y18	MIPI_CSI_D3N	MIPI_CSI_D3N				A		NA			
W18	MIPI_CSI_D3P	MIPI_CSI_D3P				A		NA			
W16	MIPI_CSI_CLKP	MIPI_CSI_CLKP				A		NA			
Y16	MIPI_CSI_CLKN	MIPI_CSI_CLKN				A		NA			
U12	MIPI_CSI_EXTR	MIPI_CSI_EXTR				A		NA			
P7	TEST	TEST				I		down			PMUIO
T1	NPOR	NPOR				I		up			3.3V
P2	XOUT_24M	XOUT_24M				O		NA			PLL_1V0

Pin	Pin Name	Func1	Func2	Func3	Func4	Pad Type	De f [®]	Pull	Drive Strengt h [®]	IN T [®]	DIE Power domain
P1	XIN_24M	XIN_24M				I		NA			
Y1	HDMI_TXCN	HDMI_TXCN				A		NA			HDMI
W1	HDMI_TXCP	HDMI_TXCP				A		NA			
W2	HDMI_TX0N	HDMI_TX0N				A		NA			
W3	HDMI_TX0P	HDMI_TX0P				A		NA			
W4	HDMI_TX1N	HDMI_TX1N				A		NA			
Y4	HDMI_TX1P	HDMI_TX1P				A		NA			
Y5	HDMI_TX2N	HDMI_TX2N				A		NA			
W5	HDMI_TX2P	HDMI_TX2P				A		NA			
U6	HDMI_EXTR	HDMI_EXTR				A		NA			
W13	USB1_DP	USB1_DP				A		NA			USB
Y13	USB1_DM	USB1_DM				A		NA			
U10	USB_EXTR	USB_EXTR				A		NA			
V12	USB_VBUS	USB_VBUS				A		NA			
V11	USB0_ID	USB0_ID				A		NA			
Y12	USB0_DM	USB0_DM				A		NA			
W12	USB0_DP	USB0_DP				A		NA			
A17	CODEC_MICBIAS	CODEC_MICBIAS				A		NA			Audio Codec
C15	CODEC_MICL	CODEC_MICL				A		NA			
B15	CODEC_MICR	CODEC_MICR				A		NA			
B16	CODEC_VCM	CODEC_VCM				A		NA			
A15	CODEC_AOL	CODEC_AOL				A		NA			
A16	CODEC_AOR	CODEC_AOR				A		NA			
A14	VIDEO_IN_P	VIDEO_IN_P				A		NA			VADC_AVDD
B14	VIDEO_IN_N	VIDEO_IN_N				A		NA			D
W6	VDAC_EXTR	VDAC_EXTR				P		NA			VADC_AVDD
Y6	VDAC_OUT	VDAC_OUT				A		NA			D
D13	ADC_IN0	ADC_IN0				A		NA			SAR_AVDD _18
E13	ADC_IN1	ADC_IN1				A		NA			
E12	ADC_IN2	ADC_IN2				A		NA			
D10	ADC_IN3	ADC_IN3				A		NA			
F12	ADC_IN4	ADC_IN4				A		NA			
E11	ADC_IN5	ADC_IN5				A		NA			
N3	EFUSE	EFUSE				P		NA			EFUSE
F3	DDR_DQ0	DDR_DQ0				A		NA			
E2	DDR_DQ1	DDR_DQ1				A		NA			
G5	DDR_DQ2	DDR_DQ2				A		NA			
F1	DDR_DQ3	DDR_DQ3				A		NA			
D3	DDR_DQ4	DDR_DQ4				A		NA			
G2	DDR_DQ5	DDR_DQ5				A		NA			
F4	DDR_DQ6	DDR_DQ6				A		NA			
E3	DDR_DQ7	DDR_DQ7				A		NA			

Pin	Pin Name	Func1	Func2	Func3	Func4	Pad Type ①	De f [®]	Pull	Drive Strengt h [®]	IN T [®]	DIE Power domain
K2	DDR_DQ8	DDR_DQ8				A		NA			DDR_VDD
J4	DDR_DQ9	DDR_DQ9				A		NA			
M2	DDR_DQ10	DDR_DQ10				A		NA			
L2	DDR_DQ11	DDR_DQ11				A		NA			
K5	DDR_DQ12	DDR_DQ12				A		NA			
H4	DDR_DQ13	DDR_DQ13				A		NA			
L4	DDR_DQ14	DDR_DQ14				A		NA			
L1	DDR_DQ15	DDR_DQ15				A		NA			
J3	DDR_DQS0	DDR_DQS0				A		NA			
K4	DDR_DQS0n	DDR_DQS0n				A		NA			
H2	DDR_DQS1	DDR_DQS1				A		NA			
H3	DDR_DQS1n	DDR_DQS1n				A		NA			
G1	DDR_DM0	DDR_DM0				A		NA			
L3	DDR_DM1	DDR_DM1				A		NA			
E4	PZQ	PZQ				A		NA			
F6	VREF	VREF				A		NA			
B4	DDR_A0	DDR_A0				A		NA			
B10	DDR_A1	DDR_A1				A		NA			
A3	DDR_A2	DDR_A2				A		NA			
E6	DDR_A3	DDR_A3				A		NA			
B6	DDR_A4	DDR_A4				A		NA			
B3	DDR_A5	DDR_A5				A		NA			
A6	DDR_A6	DDR_A6				A		NA			
A2	DDR_A7	DDR_A7				A		NA			
A10	DDR_A8	DDR_A8				A		NA			
E7	DDR_A9	DDR_A9				A		NA			
C9	DDR_A10	DDR_A10				A		NA			
B5	DDR_A11	DDR_A11				A		NA			
B7	DDR_A12	DDR_A12				A		NA			
D7	DDR_A13	DDR_A13				A		NA			
A5	DDR_A14	DDR_A14				A		NA			
C3	DDR_CLK	DDR_CLK				A		NA			
C2	DDR_CLKn	DDR_CLKn				A		NA			
B2	DDR_BA0	DDR_BA0				A		NA			
C8	DDR_BA1	DDR_BA1				A		NA			
D6	DDR_BA2	DDR_BA2				A		NA			
C5	DDR_ODT0	DDR_ODT0				A		NA			
B1	DDR_CSN	DDR_CSN				A		NA			
B9	DDR_CKE	DDR_CKE				A		NA			
D5	DDR_RASN	DDR_RASN				A		NA			
D8	DDR_CASN	DDR_CASN				A		NA			
E8	DDR_WEN	DDR_WEN				A		NA			

Pin	Pin Name	Func1	Func2	Func3	Func4	Pad Type	De f®	Pull	Drive Strengt h®	IN T®	DIE Power domain
F5	DDR_RESET	DDR_RESET				A		NA			
J6	DDR_VDD_1	DDR_VDD_1				A		NA			
H6	DDR_VDD_2	DDR_VDD_2				A		NA			
G6	DDR_VDD_3	DDR_VDD_3				A		NA			
E10	DDR_VDD_4	DDR_VDD_4				A		NA			
F7	DDR_VDD_5	DDR_VDD_5				A		NA			
F8	DDR_VDD_6	DDR_VDD_6				A		NA			
F9	DDR_VDD_7	DDR_VDD_7				A		NA			

Table 2-6 RK1108B function IO description

Pin	Pin Name	Func1	Func2	Func3	Func4	Pad Type	De f®	Pull	Drive Strengt h®	IN T®	DIE Power domain
T7	GPIO0_A1/SDMMC0_DET	GPIO0_A1	SDMMC0_DET			I/O	I	up	4	✓	
U1	GPIO0_A2/SDMMC1_PWR	GPIO0_A2	SDMMC1_PWR			I/O	I	down	4	✓	
P4	GPIO0_A3/SPI_CLK	GPIO0_A3	SPI_CLK			I/O	I	down	4	✓	
P5	GPIO0_A4/SPI_CSN0	GPIO0_A4	SPI_CSN0			I/O	I	down	4	✓	
V2	GPIO0_A5/CLK_WIFI_OUT	GPIO0_A5	CLK_WIFI_OUT			I/O	I	up	4	✓	
V1	GPIO0_A6/PMU_DEBUG0	GPIO0_A6	PMU_DEBUG0			I/O	I	down	4	✓	
M3	GPIO0_A7/SPI_TXD	GPIO0_A7	SPI_TXD			I/O	I	down	4	✓	
U5	GPIO0_B0/SPI_RXD	GPIO0_B0	SPI_RXD			I/O	I	down	4	✓	
T4	GPIO0_B1/I2C0_SCL	GPIO0_B1	I2C0_SCL			I/O	I	up	4	✓	
R4	GPIO0_B2/I2C0_SDA	GPIO0_B2	I2C0_SDA			I/O	I	up	4	✓	
R2	GPIO0_B3	GPIO0_B3				I/O	I	up	4	✓	PMUIO IO Voltage 3.3V
T5	GPIO0_B4	GPIO0_B4				I/O	I	up	4	✓	
N5	GPIO0_B5/PMIC_SLEEP	GPIO0_B5	PMIC_SLEEP			I/O	I	down	4	✓	
N1	GPIO0_B6/I2C3_SCL	GPIO0_B6	I2C3_SCL			I/O	I	up	4	✓	
M5	GPIO0_B7/TSADC_SHUT	GPIO0_B7	TSADC_SHUT			I/O	I	up	4	✓	
M4	GPIO0_C0/PWM3/IR	GPIO0_C0	PWM3	IR		I/O	I	down	4	✓	
U3	GPIO0_C1/HDMI_HPD1/CVBS_CLK_IN	GPIO0_C1	HDMI_HPD1	CVBS_CLK_IN		I/O	I	down	4	✓	
U2	GPIO0_C2/PMU_DEBUG1	GPIO0_C2	PMU_DEBUG1			I/O	I	down	4	✓	
P6	GPIO0_C3/PMU_DEBUG2	GPIO0_C3	PMU_DEBUG2			I/O	I	down	4	✓	
T3	GPIO0_C4/PWM1/I2C3_SDA	GPIO0_C4	PWM1	I2C3_SDA		I/O	I	up	4	✓	
T2	GPIO0_C5/PWM0/PMU_DEBUG3	GPIO0_C5	PWM0	PMU_DEBUG3		I/O	I	down	4	✓	

Pin	Pin Name	Func1	Func2	Func3	Func4	Pad Type	De f®	Pull	Drive Strengt h®	IN T®	DIE Power domain
R3	GPIO0_C6/PWM2/PMU_DEBUG4	GPIO0_C6	PWM2	PMU_DEBUG4		I/O	I	down	4	✓	
Y9	GPIO1_A0/LCDC_D0/MIPI_CLKP	GPIO1_A0	LCDC_D0	MIPI_CLKP		A		NA		✓	MIPI_DSI
W9	GPIO1_A1/LCDC_D1/MIPI_CLKN	GPIO1_A1	LCDC_D1	MIPI_CLKN		A		NA		✓	
W11	GPIO1_A2/LCDC_D2/MIPI_D0P	GPIO1_A2	LCDC_D2	MIPI_D0P		A		NA		✓	
Y11	GPIO1_A3/LCDC_D3/MIPI_D0N	GPIO1_A3	LCDC_D3	MIPI_D0N		A		NA		✓	
W10	GPIO1_A4/LCDC_D4/MIPI_D1P	GPIO1_A4	LCDC_D4	MIPI_D1P		A		NA		✓	
Y10	GPIO1_A5/LCDC_D5/MIPI_D1N	GPIO1_A5	LCDC_D5	MIPI_D1N		A		NA		✓	
Y8	GPIO1_A6/LCDC_D6/MIPI_D2P	GPIO1_A6	LCDC_D6	MIPI_D2P		A		NA		✓	
W8	GPIO1_A7/LCDC_D7/MIPI_D2N/PWM5	GPIO1_A7	LCDC_D7	MIPI_D2N	PWM5	A		NA		✓	
Y7	GPIO1_B0/LCDC_D8/MIPI_D3P/PWM6	GPIO1_B0	LCDC_D8	MIPI_D3P	PWM6	A		NA		✓	
W7	GPIO1_B1/LCDC_D9/MIPI_D3N/PWM7	GPIO1_B1	LCDC_D9	MIPI_D3N	PWM7	A		NA		✓	
F17	GPIO1_B2/LCDC_D17/I2S_SDO/GMAC_TXD0	GPIO1_B2	LCDC_D17	I2S_SDO	GMAC_TXD0	I/O	I	down	8	✓	APIO1 IO Voltage 3.3V
B20	GPIO1_B3/LCDC_D16/I2S_SCLK/GMAC_TXD1	GPIO1_B3	LCDC_D16	I2S_SCLK	GMAC_TXD1	I/O	I	down	8	✓	
C19	GPIO1_B4/LCDC_D15/I2S_MCLK/GMAC_TXEN	GPIO1_B4	LCDC_D15	I2S_MCLK	GMAC_TXEN	I/O	I	down	8	✓	
F18	GPIO1_B5/LCDC_D14/I2S_SDIO1/GMAC_RXD0	GPIO1_B5	LCDC_D14	I2S_SDIO1	GMAC_RXD0	I/O	I	down	8	✓	
C20	GPIO1_B6/LCDC_D13/I2S_LRCLKTX/GMAC_RXD1	GPIO1_B6	LCDC_D13	I2S_LRCLKTX	GMAC_RXD1	I/O	I	down	8	✓	
G16	GPIO1_B7/LCDC_D12/I2S_SDIO2/GMAC_RXDV	GPIO1_B7	LCDC_D12	I2S_SDIO2	GMAC_RXDV	I/O	I	down	8	✓	
E18	GPIO1_C0/LCDC_D11/I2S_LRCLKRX	GPIO1_C0	LCDC_D11	I2S_LRCLKRX		I/O	I	down	8	✓	
E19	GPIO1_C1/LCDC_D10/I2S_SDI/PWM4	GPIO1_C1	LCDC_D10	I2S_SDI	PWM4	I/O	I	down	8	✓	
D20	GPIO1_C2/LCDC_DEN/I2S_SDIO3/GMAC_RXER	GPIO1_C2	LCDC_DEN	I2S_SDIO3	GMAC_RXER	I/O	I	down	8	✓	
E20	GPIO1_C3/LCDC_VSYNC/GMAC_MDIO	GPIO1_C3	LCDC_VSYNC	GMAC_MDIO		I/O	I	down	8	✓	
F19	GPIO1_C4/LCDC_HSYNC/GMAC_MDC	GPIO1_C4	LCDC_HSYNC	GMAC_MDC		I/O	I	down	8	✓	
G17	GPIO1_C5/LCDC_CLK/GMAC_CLK	GPIO1_C5	LCDC_CLK	GMAC_CLK		I/O	I	down	8	✓	
A18	GPIO1_D0/UART0_CTSN/SPI_CLK/DSP_TCK	GPIO1_D0	UART0_CTSN	SPI_CLK	DSP_TCK	I/O	I	down	4	✓	
A19	GPIO1_D1/UART0_RTSEN/SPI_CSNO/DSP_TMS	GPIO1_D1	UART0_RTSEN	SPI_CSNO	DSP_TMS	I/O	I	up	4	✓	
D19	GPIO1_D2/UART0_RXSPI_RXD/D	GPIO1_D2	UART0_RX	SPI_RXD		I/O	I	up	4	✓	
B18	GPIO1_D3/UART0_TX/SPI_TXD/D	GPIO1_D3	UART0_TX	SPI_TXD		I/O	I	down	4	✓	

Pin	Pin Name	Func1	Func2	Func3	Func4	Pad Type	De f®	Pull	Drive Strengt h®	IN T®	DIE Power domain
E17	5VGPIO1_D4/UART2_CTSN/HDMI_I2C0_SCL	5VGPIO1_D4	UART2_CTSN	HDMI_I2C0_SCL		I/O	I	up	4	✓	
C17	5VGPIO1_D5/UART2_RTSN/HDMI_I2C0_SDA	5VGPIO1_D5	UART2_RTSN	HDMI_I2C0_SDA		I/O	I	up	4	✓	
C18	5VGPIO1_D6/HDMI_HPD0	5VGPIO1_D6	HDMI_HPD0			I/O	I	down	4	✓	
A20	GPIO1_D7/HDMI_CEC/DSP_RTCK	GPIO1_D7	HDMI_CEC	DSP_RTCK		I/O	I	up	4	✓	
F16	GPIO2_D1/UART2_RX/JTAG_TMS	GPIO2_D1	UART2_RX	JTAG_TMS		I/O	I	up	4	✓	
E16	GPIO2_D2/UART2_TX/JTAG_TCK	GPIO2_D2	UART2_TX	JTAG_TCK		I/O	I	up	4	✓	
T19	GPIO2_D3/I2C1_SDA	GPIO2_D3	I2C1_SDA			I/O	I	up	4	✓	
R17	GPIO2_D4/I2C1_SCL	GPIO2_D4	I2C1_SCL			I/O	I	up	4	✓	
M19	GPIO2_D5/SDIO_CLKO	GPIO2_D5	SDIO_CLKO			I/O	I	down	4	✓	
L20	GPIO2_D6/SDIO_CMD	GPIO2_D6	SDIO_CMD			I/O	I	up	8	✓	
L19	GPIO2_D7/SDIO_D0	GPIO2_D7	SDIO_D0			I/O	I	up	8	✓	
M18	GPIO3_A0/SDIO_D1	GPIO3_A0	SDIO_D1			I/O	I	up	8	✓	
M20	GPIO3_A1/SDIO_D2	GPIO3_A1	SDIO_D2			I/O	I	up	8	✓	
M17	GPIO3_A2/SDIO_D3	GPIO3_A2	SDIO_D3			I/O	I	up	8	✓	
R20	GPIO3_A3/UART1_RTSN	GPIO3_A3	UART1_RTSN			I/O	I	up	4	✓	
P18	GPIO3_A4/UART1_CTSN	GPIO3_A4	UART1_CTSN			I/O	I	up	4	✓	APIO2 IO Vlotage 1.8V
T20	GPIO3_A5/UART1_RX	GPIO3_A5	UART1_RX			I/O	I	up	4	✓	
P17	GPIO3_A6/UART1_TX	GPIO3_A6	UART1_TX			I/O	I	up	4	✓	
P19	GPIO3_A7	GPIO3_A7				I/O	I	down	4	✓	
U20	GPIO3_B0	GPIO3_B0				I/O	I	down	4	✓	
N16	GPIO3_B1/PCM_OUT/FLASH_TRIG_OUT	GPIO3_B1	PCM_OUT	FLASH_TRIG_OUT		I/O	I	down	4	✓	
N18	GPIO3_B2/PCM_IN/FLASH_TRIG_IN	GPIO3_B2	PCM_IN	FLASH_TRIG_IN		I/O	I	down	4	✓	
R19	GPIO3_B3/PCM_CLK	GPIO3_B3	PCM_CLK			I/O	I	down	4	✓	
N20	GPIO3_B4/PCM_SYNC/PRELIGHT_TRIG_OUT	GPIO3_B4	PCM_SYNC	PRELIGHT_TRIG_OUT		I/O	I	down	4	✓	
P20	GPIO3_B5/MIPI_CSI_MCLK	GPIO3_B5	MIPI_CSI_MCLK			I/O	I	down	4	✓	
N1	GPIO3_B6	GPIO3_B6				I/O	I	down	4	✓	

Pin	Pin Name	Func1	Func2	Func3	Func4	Pad Type	De f®	Pull	Drive Strengt h®	IN T®	DIE Power domain
9											
D1 1	GPIO3_B7/SDMMC0_D3	GPIO3_B7	SDMMC0_D3			I/O	I	up	8	✓	APIO3 IO Voltage 3.3V/1.8V
C1 2	GPIO3_C0/SDMMC0_D2	GPIO3_C0	SDMMC0_D2			I/O	I	up	8	✓	
D1 2	GPIO3_C1/SDMMC0_D1/UART2_RX	GPIO3_C1	SDMMC0_D1	UART2_RX		I/O	I	up	8	✓	
A1 2	GPIO3_C2/SDMMC0_D0/UART2_TX	GPIO3_C2	SDMMC0_D0	UART2_TX		I/O	I	up	8	✓	
B1 2	GPIO3_C3/SDMMC0_CLKO	GPIO3_C3	SDMMC0_CLKO			I/O	I	down	8	✓	
B1 3	GPIO3_C4/SDMMC0_CMD	GPIO3_C4	SDMMC0_CMD			I/O	I	up	8	✓	
A1 3	GPIO3_C5/SDMMC0_PWR	GPIO3_C5	SDMMC0_PWR			I/O	I	down	4	✓	
V2 0	GPIO1_C6/CIF_D4/I2S_LRCLKTX	GPIO1_C6	CIF_D4	I2S_LRCLKTX		I/O	I	down	8	✓	APIO3 IO Voltage 3.3V/1.8V
U1 9	GPIO1_C7/CIF_D5/I2S_SDIO2	GPIO1_C7	CIF_D5	I2S_SDIO2		I/O	I	down	8	✓	
Y19	GPIO2_C0/CIF_D6/I2S_LRCLKRX	GPIO2_C0	CIF_D6	I2S_LRCLKRX		I/O	I	down	8	✓	
U1 4	GPIO2_C1/CIF_D7/I2S_SDI	GPIO2_C1	CIF_D7	I2S_SDI		I/O	I	down	8	✓	
V1 6	GPIO2_C3/CIF_D0/I2S_SDO	GPIO2_C3	CIF_D0	I2S_SDO		I/O	I	down	8	✓	
U1 6	GPIO2_C4/CIF_D1/I2S_SCLK	GPIO2_C4	CIF_D1	I2S_SCLK		I/O	I	down	8	✓	
U1 5	GPIO2_C5/CIF_D2/I2S_MCLK	GPIO2_C5	CIF_D2	I2S_MCLK		I/O	I	down	8	✓	
V1 4	GPIO2_C6/CIF_D3/I2S_SDIO1	GPIO2_C6	CIF_D3	I2S_SDIO1		I/O	I	down	8	✓	
V1 9	GPIO3_C6/CIF_VSYNC	GPIO3_C6	CIF_VSYNC			I/O	I	down	8	✓	
T18	GPIO3_C7/CIF_CLKIN	GPIO3_C7	CIF_CLKIN			I/O	I	down	8	✓	
U1 8	GPIO3_D0/CIF_HREF	GPIO3_D0	CIF_HREF			I/O	I	down	8	✓	
T17	GPIO3_D1/CIF_PDN	GPIO3_D1	TCIF_PDN			I/O	I	down	8	✓	
V1 8	GPIO3_D2/CIF_CLKOUT	GPIO3_D2	CIF_CLKOUT			I/O	I	down	8	✓	
Y20	GPIO3_D3/CIF_D8/I2S_SDIO3	GPIO3_D3	CIF_D8	I2S_SDIO3		I/O	I	down	8	✓	
U1 7	GPIO3_D4/CIF_D9/FLASH_TRIG_IN	GPIO3_D4	CIF_D9	FLASH_TRIG_IN		I/O	I	down	8	✓	
R1 6	GPIO3_D5/CIF_D10/FLASH_TRIG_OUT	GPIO3_D5	CIF_D10	FLASH_TRIG_OUT		I/O	I	down	8	✓	

Pin	Pin Name	Func1	Func2	Func3	Func4	Pad Type	De f®	Pull	Drive Strengt h®	IN T®	DIE Power domain
W20	GPIO3_D6/CIF_D11/PRELIGHT_TRIG_OUT	GPIO3_D6	CIF_D11	PRELIGHT_TRIG_OUT		I/O	I	down	8	✓	
K18	GPIO2_A0/FLASH_D0/EMMC_D0/SFC_SIO_I00	GPIO2_A0	FLASH_D0	EMMC_D0	SFC_SIO_I00	I/O	I	up	8	✓	APIO6 IO Voltage 3.3V/1.8V
J16	GPIO2_A1/FLASH_D1/EMMC_D1/SFC_SIO_I01	GPIO2_A1	FLASH_D1	EMMC_D1	SFC_SIO_I01	I/O	I	up	8	✓	
K17	GPIO2_A2/FLASH_D2/EMMC_D2/SFC_WP_IO2	GPIO2_A2	FLASH_D2	EMMC_D2	SFC_WP_I02	I/O	I	up	8	✓	
H19	GPIO2_A3/FLASH_D3/EMMC_D3/SFC_HOLD_IO3	GPIO2_A3	FLASH_D3	EMMC_D3	SFC_HOLD_IO3	I/O	I	up	8	✓	
G20	GPIO2_A4/FLASH_D4/EMMC_D4	GPIO2_A4	FLASH_D4	EMMC_D4		I/O	I	up	8	✓	
J19	GPIO2_A5/FLASH_D5/EMMC_D5	GPIO2_A5	FLASH_D5	EMMC_D5		I/O	I	up	8	✓	
L16	GPIO2_A6/FLASH_D6/EMMC_D6	GPIO2_A6	FLASH_D6	EMMC_D6		I/O	I	up	8	✓	
H20	GPIO2_A7/FLASH_D7/EMMC_D7	GPIO2_A7	FLASH_D7	EMMC_D7		I/O	I	up	8	✓	
H18	GPIO2_B0/FLASH_ALE	GPIO2_B0	FLASH_ALE			I/O	I	down	8	✓	
F20	GPIO2_B1/FLASH_CLE	GPIO2_B1	FLASH_CLE			I/O	I	down	8	✓	
K19	GPIO2_B2/FLASH_WRN	GPIO2_B2	FLASH_WRN			I/O	I	up	8	✓	
L17	GPIO2_B3/FLASH_RDN	GPIO2_B3	FLASH_RDN			I/O	I	up	8	✓	
G19	GPIO2_B4/FLASH_RDY/EMMC_CMD/SFC_CS_N0	GPIO2_B4	FLASH_RDY	EMMC_CMD	SFC_CS_N0	I/O	I	up	8	✓	
J20	GPIO2_B5/FLASH_CS0/	GPIO2_B5	FLASH_CS0			I/O	I	up	8	✓	
K20	GPIO2_B6/EMMC_CLK0/	GPIO2_B6	EMMC_CLK0			I/O	I	down	8	✓	
J18	GPIO2_B7/FLASH_CS1/SFC_CLK	GPIO2_B7	FLASH_CS1	SFC_CLK		I/O	I	up	8	✓	
H17	GPIO2_C2/FLASH_WP/EMMC_PWR/	GPIO2_C2	FLASH_WP	EMMC_PWR		I/O	I	down	8	✓	
W14	MIPI_CSI_D0N	MIPI_CSI_D0N				A		NA			MIPI_CSI
Y14	MIPI_CSI_D0P	MIPI_CSI_D0P				A		NA			
W15	MIPI_CSI_D1N	MIPI_CSI_D1N				A		NA			
Y15	MIPI_CSI_D1P	MIPI_CSI_D1P				A		NA			
W1	MIPI_CSI_D2N	MIPI_CSI_D2				A		NA			

Pin	Pin Name	Func1	Func2	Func3	Func4	Pad Type	De f®	Pull	Drive Strengt h®	IN T®	DIE Power domain
7		N									
Y17	MIPI_CSI_D2P	MIPI_CSI_D2P				A		NA			
Y18	MIPI_CSI_D3N	MIPI_CSI_D3N				A		NA			
W18	MIPI_CSI_D3P	MIPI_CSI_D3P				A		NA			
W16	MIPI_CSI_CLKP	MIPI_CSI_CLKP				A		NA			
Y16	MIPI_CSI_CLKN	MIPI_CSI_CLKN				A		NA			
U12	MIPI_CSI_EXTR	MIPI_CSI_EXTR				A		NA			
P7	TEST	TEST				I		down			PMUIO
T1	NPOR	NPOR				I		up			3.3V
P2	XOUT_24M	XOUT_24M				O		NA			PLL_1V0
P1	XIN_24M	XIN_24M				I		NA			
Y1	HDMI_TXCN	HDMI_TXCN				A		NA			
W1	HDMI_TXCP	HDMI_TXCP				A		NA			
W2	HDMI_TX0N	HDMI_TX0N				A		NA			
W3	HDMI_TX0P	HDMI_TX0P				A		NA			
W4	HDMI_TX1N	HDMI_TX1N				A		NA			
Y4	HDMI_TX1P	HDMI_TX1P				A		NA			
Y5	HDMI_TX2N	HDMI_TX2N				A		NA			
W5	HDMI_TX2P	HDMI_TX2P				A		NA			
U6	HDMI_EXTR	HDMI_EXTR				A		NA			
W13	USB1_DP	USB1_DP				A		NA			
Y13	USB1_DM	USB1_DM				A		NA			
U10	USB_EXTR	USB_EXTR				A		NA			
V12	USB_VBUS	USB_VBUS				A		NA			USB
V11	USB0_ID	USB0_ID				A		NA			
Y12	USB0_DM	USB0_DM				A		NA			
W12	USB0_DP	USB0_DP				A		NA			
A17	CODEC_MICBIAS	CODEC_MICBIAS				A		NA			Audio
C15	CODEC_MICL	CODEC_MICL				A		NA			Codec
B1	CODEC_MICR	CODEC_MICR				A		NA			

Pin	Pin Name	Func1	Func2	Func3	Func4	Pad Type	Def ^②	Pull	Drive Strength ^③	INT ^④	DIE Power domain
5											
B1 6	CODEC_VCM	CODEC_VCM				A		NA			
A1 5	CODEC_AOL	CODEC_AOL				A		NA			
A1 6	CODEC_AOR	CODEC_AOR				A		NA			
A1 4	VIDEO_IN_P	VIDEO_IN_P				A		NA			VADC_AVDD
B1 4	VIDEO_IN_N	VIDEO_IN_N				A		NA			D
W6	VDAC_EXTR	VDAC_EXTR				P		NA			VDAC_AVDD
Y6	VDAC_OUT	VDAC_OUT				A		NA			D
D1 3	ADC_IN0	ADC_IN0				A		NA			
E13	ADC_IN1	ADC_IN1				A		NA			
E12	ADC_IN2	ADC_IN2				A		NA			SAR_AVDD
D1 0	ADC_IN3	ADC_IN3				A		NA			_18
F12	ADC_IN4	ADC_IN4				A		NA			
E11	ADC_IN5	ADC_IN5				A		NA			
N3	EFUSE	EFUSE				P		NA			EFUSE
E4	PZQ	PZQ				A		NA			
F6	VREF	VREF				A		NA			
J6	DDR_VDD_1	DDR_VDD_1				A		NA			
H6	DDR_VDD_2	DDR_VDD_2				A		NA			
G6	DDR_VDD_3	DDR_VDD_3				A		NA			
E10	DDR_VDD_4	DDR_VDD_4				A		NA			
F7	DDR_VDD_5	DDR_VDD_5				A		NA			
F8	DDR_VDD_6	DDR_VDD_6				A		NA			
F9	DDR_VDD_7	DDR_VDD_7				A		NA			

Notes:

①:Type: I = input, O = output, I/O = input/output (bidirectional)

AP = Analog Power, AG = Analog Ground

DP = Digital Power, DG = Digital Ground

A = Analog

②:Output Drive Unit is mA, only Digital IO has drive value;

③:Def: I = input without any pull resistor, O = output without any pull resistor;

④:INT: interrupt

2.8 IO Pin Name Description

This sub-chapter will focus on the detailed function description of every pins based on different interface.

2.8.1 MISC

Interface	Pin Name	Direction	Description
Misc	XIN_24M	I	Clock input of 24MHz crystal
	XOUT_24M	O	Clock output of 24MHz crystal
	NPOR	I	Chip hardware reset

2.8.2 JTAG

Interface	Pin Name	Direction	Description
SWJ-DP	JTAG_TMS	I/O	JTAG interface TMS input/SWD interface data out
	JTAG_TCK	I	JTAG interface clock input/SWD interface clock input

2.8.3 SDMMC

Interface	Pin Name	Direction	Description
SDMMC Host Controller	SDMMC0_D <i>(i=0~3)</i>	I/O	sdmmc card data input and output
	SDMMC0_CLKO	O	sdmmc card clock
	SDMMC0_CMD	I/O	sdmmc card command output and response input
	SDMMC0_DET	I	sdmmc card detect signal, 0 represents presence of card

2.8.4 SDIO

Interface	Pin Name	Direction	Description
SDIO Host Controller	SDIO_CLKO	O	sdio clock
	SDIO_CMD	I/O	sdio command output and response input
	SDIO_DATA <i>(i=0~3)</i>		sdio data input and output

2.8.5 EMMC

Interface	Pin Name	Direction	Description
EMMC Interface	EMMC_CLKO	O	emmc card clock
	EMMC_CMD	I/O	emmc card command output and response input
	EMMC_DATA <i>(i=0~7)</i>	I/O	emmc card data input and output

2.8.6 DDR3

Interface	Pin Name	Direction	Description
DMC	DDR_CLK	O	Active-high clock signal to the memory device.
	DDR_CLKn	O	Active-low clock signal to the memory device.
	DDR_CKE	O	Active-high clock enable signal to the memory device
	DDR_CSN	O	Active-low chip select signal to the memory device. There are two chip select.
	DDR_RASN	O	Active-low row address strobe to the memory device.

Interface	Pin Name	Direction	Description
	DDR_CASN	O	Active-low column address strobe to the memory device.
	DDR_WEN	O	Active-low write enable strobe to the memory device.
	DDR_RESET	O	DDR3 reset signal to the memory device
	DDR_Bai($i=0,1,2$)	O	Bank address signal to the memory device.
	DDR_Ai($i=0\sim 14$)	O	Address signal to the memory device.
	DDR_ODT0	O	On-Die Termination output signal for two chip select.
	DDR_Dmi($i=0,1$)	O	Active-low data mask signal to the memory device.
	DDR_DQS0/1	I/O	Active-high bidirectional data strobes to the memory device.
	DDR_DQS0n/1n	I/O	Active-low bidirectional data strobes to the memory device.
DDR_Dqi($i=0\sim 15$)	I/O	Bidirectional data line to the memory device.	

2.8.7 NAND FLASH

Interface	Pin Name	Direction	Description
NAND	FLASH_ALE	O	Flash address latch enable signal
	FLASH_CLE	O	Flash command latch enable signal
	FLASH_WRN	O	Flash write enable and clock signal
	FLASH_RDN	O	Flash read enable and write/read signal
	FLASH_RDY	I	Flash ready/busy signal
	FLASH_Csi($i=0,1$)	O	Flash chip enable signal for chip
	FLASH_WP	O	Flash write-protected signal
	FLASH_DATAi($i=0\sim 7$)	I/O	Flash data inputs/outputs signal

2.8.8 SPI FLASH

Interface	Pin Name	Direction	Description
SPI Flash	SFC_SIO_IO0	I/O	Data Input Output 0
	SFC_SIO_IO1	I/O	Data Input Output 1
	SFC_WP_IO2	I/O	Write Protect Output (Data Input Output 2)
	SFC_HOLD_IO3	I/O	Hold t Input (Data Input Output 3)
	SFC_CSN0	O	Chip Select
	SFC_CLK	O	Serial Clock Output

2.8.9 PCM

Interface	Pin Name	Direction	Description
PCM	PCM_OUT	O	PCM serial data output
	PCM_IN	I	PCM serial data input
	PCM_CLK	O	PCM clock source
	PCM_SYNC	I/O	PCM serial data synchronous

2.8.10 I2S

Interface	Pin Name	Direction	Description
-----------	----------	-----------	-------------

I2S Controller	I2S_SCLK	I/O	I2S serial clock
	I2S_MCLK	O	I2S clock source
	I2S_LRCLKTX	I/O	I2S left & right channel signal for transmitting serial data, synchronous left & right channel in I2S mode
	I2S_SDIOi(i=0~3)	O	I2S serial data output
	I2S_LRCLKRX	I/O	I2S left & right channel signal for receiving serial data, synchronous left & right channel in I2S mode
	I2S_SDI	I/O	I2S serial data input

2.8.11 SPI

Interface	Pin Name	Direction	Description
SPI Controller	SPI_CLK	I/O	SPI serial clock
	SPI_CSN0	I/O	SPI chip select signal ,low active
	SPI_TXD	O	SPI serial data output
	SPI_RXD	I	SPI serial data input

2.8.12 PWM

Interface	Pin Name	Direction	Description
PWM	PWM0	O	Pulse Width Modulation output
	PWM1	O	Pulse Width Modulation output
	PWM2	O	Pulse Width Modulation output
	PWM3	O	Pulse Width Modulation output
	PWM4	O	Pulse Width Modulation output
	PWM5	O	Pulse Width Modulation output
	PWM6	O	Pulse Width Modulation output
	PWM7	O	Pulse Width Modulation output

2.8.13 I2C

Interface	Pin Name	Direction	Description
I2C	I2C0_SDA	I/O	I2C0 data
	I2C0_SCL	I/O	I2C0 clock
	I2C1_SDA	I/O	I2C1 data
	I2C1_SCL	I/O	I2C1 clock
	I2C3_SDA	I/O	I2C3 data
	I2C3_SCL	I/O	I2C3 clock

2.8.14 UART

Interface	Pin Name	Direction	Description
UART	UART0_CTSN	I	UART0 clear to send
	UART0_RTSEN	O	UART0 request to send
	UART0_RX	I	UART0 serial data input
	UART0_TX	O	UART0 serial data output
	UART2_CTSN	I	UART0 clear to send
	UART2_RTSEN	O	UART0 request to send

	UART2_RX	I	UART0 serial data input
	UART2_TX	O	UART0 serial data output
	UART1_CTSN	I	UART0 clear to send
	UART1_RTSN	O	UART0 request to send
	UART1_RTX	I	UART0 serial data input
	UART1_TX	O	UART0 serial data output

2.8.15 GMAC

Interface	Pin Name	Direction	Description
GMAC	GMAC_TXDi(i=0~1)	O	GMAC TX data
	GMAC_RXDi(i=0~1)	I	GMAC RX data
	GMAC_TXEN	O	GMAC TX data enable
	GMAC_RXDV	I	Collision and Data Valid
	GMAC_RXER	I	GMAC RX error signal
	GMAC_MDIO	I/O	GMAC management interface data
	GMAC_MDC	O	GMAC management interface clock
	GMAC_CLK	I/O	RMI REC_CLK output or GMAC external clock input

2.8.16 USB

Interface	Pin Name	Direction	Description
USB OTG 2.0	USB0_DM	I/O	USB OTG 2.0 Data signal DM
	USB0_DP	I/O	USB OTG 2.0 Data signal DP

Interface	Pin Name	Direction	Description
USB HOST 2.0	USB1_DP	I/O	USB HOST 2.0 Data signal DP
	USB1_DM	I/O	USB HOST 2.0 Data signal DM

2.8.17 EFUSE

Interface	Pin Name	Direction	Description
EFUSE	EFUSE	N/A	eFuse program and sense power

2.8.18 HDMI

Interface	Pin Name	Direction	Description
HDMI	HDMI_TX0N	O	TMDS channel 0 negative data line
	HDMI_TX0P	O	TMDS channel 0 positive data line
	HDMI_TX1N	O	TMDS channel 1 negative data line
	HDMI_TX1P	O	TMDS channel 1 positive data line
	HDMI_TX2N	O	TMDS channel 2 negative data line
	HDMI_TX2P	O	TMDS channel 2 positive data line
	HDMI_EXTR	O	Connect 2.0Kohm resistor to ground to generate reference current
	HDMI_HPDP0	I/O	HDMI hot plug detect signal
	HDMI_CEC	I/O	HDMI CEC signal

2.8.19 CODEC

Interface	Pin Name	Direction	Description
CODEC	CODEC_MICL	I	Left channel input

	CODEC_MICR	I	Right channel input
	CODEC_VCM	I	Reference voltage input
	CODEC_AOL	O	Left channel output
	CODEC_AOR	O	Right channel output

2.8.20 CVBSIN

Interface	Pin Name	Direction	Description
CVBSIN	VIDEO_IN_P	I	Data signal P
	VIDEO_IN_N	I	Data signal N

2.8.21 CVBSOUT

Interface	Pin Name	Direction	Description
CVBSOUT	VDAC_EXTR	I	Connect external resistor to generate current reference
	VDAC_OUT	O	Data signal output

2.8.22 SAR-ADC

Interface	Pin Name	Direction	Description
SAR-ADC	ADC_In(<i>j</i> =0~5)	I	Analog input

2.9 RK1108 IO Type

The following list shows IO type except DDR IO and all of Power/Ground IO.

Table 2-7 RK1108 IO Type List

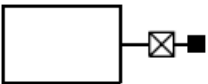
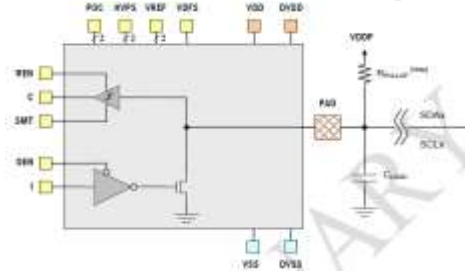
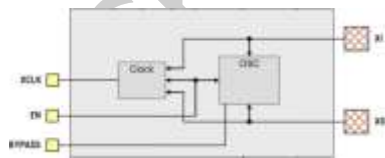
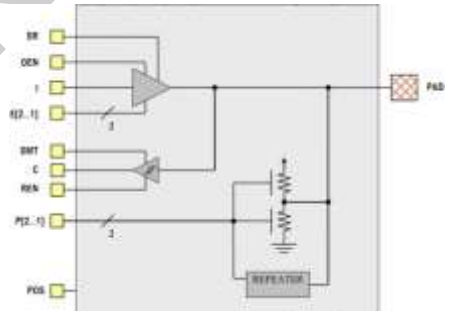
Type	Diagram	Description	Pin Name
A		Analog IO Cell with IO voltage	EFUSE_VQPS
B		Pad for 5V tolerance	hdmi_ddcscl hdmi_ddcsda hdmi_hpd
C		Crystal Oscillator with high enable	XIN24M/XOUT24M
D		Tri-state output pad with input, which pull-up/pull-down, slew rate and drive strength is configurable	Pad of digital GPIO

Chapter 3 Electrical Specification

3.1 Absolute Maximum Ratings

Table 3-1 RK1108 absolute maximum ratings

Parameters	Related Power Group	Max	Unit
DC supply voltage for Internal digital logic	CORE_VDD PMU_VDD	1.1	V
DC supply voltage for Digital GPIO	APIO1_VDD APIO2_VDD APIO3_VDD PMUIO_VDD APIO5_VDD APIO6_VDD	3.6	V
DC supply voltage for DDR IO	DDR_VDD	1.65	V
DC supply voltage for digital part of PLL	PLL_AVDD_1V0	1.1	V
DC supply voltage for Analog part of PLL	PLL_AVDD_1V8	1.98	V
DC supply voltage for Analog part of USB OTG/Host2.0	USB_AVDD_1V0 USB_AVDD_1V8 USB_AVDD_3V3	1.1 1.98 3.63	V
DC supply voltage for Analog part of Audio Codec	CODEC_AVDD_1V8	1.98	V
DC supply voltage for Analog part of VDAC	VDAC_AVDD_1V8	1.98	V
DC supply voltage for Analog part of HDMI	HDMI_AVDD_1V0 HDMI_AVDD_1V8	1.1 1.98	V
DC supply voltage for Analog part of SARADC and TSADC	SADC_AVDD_1V8	1.98	V
DC supply voltage for Analog part of DSI	MIPI_DSI_AVDD_1V0 MIPI_DSI_AVDD_1V8	1.1 1.8	V
DC supply voltage for Analog part of CSI	MIPI_CSI_AVDD_1V0	1.1	V
DC supply voltage for Digital part of VIDEOADC	VIDEO_AVDD_1V0	1.1	V
DC supply voltage for Analog part of VIDEOADC	VIDEO_AVDD_1V8	1.98	V
DC supply voltage for Analog part of EFUSE	EFUSE	1.65	V
Analog Input voltage for DP/DM/VBUS of USB OTG/Host2.0		5	V
Digital input voltage for input buffer of GPIO		3.6	V
Digital output voltage for output buffer of GPIOs		3.6	V
Storage Temperature		125	°C

Absolute maximum ratings specify the values beyond which the device may be damaged permanently. Long-term exposure to absolute maximum ratings conditions may affect device reliability.

3.2 Recommended Operating Condition

Following table describes the recommended operating condition.

Table 3-2 RK1108 recommended operating condition

Parameters	Symbol	Min	Typ	Max	Units
------------	--------	-----	-----	-----	-------

Parameters	Symbol	Min	Typ	Max	Units
Internal digital logic Power	CORE_VDD PMU_VDD	0.9	1.0	TBD	V
Digital GPIO Power(3.3V/2.5V/1.8V)	APIO1_VDD APIO2_VDD APIO3_VDD PMUIO_VDD APIO5_VDD APIO6_VDD	3 2.25 1.62	3.3 2.5 1.8	3.6 2.75 1.98	V
DDR IO (DDR3 mode) Power	DDR_VDD	1.425	1.5	1.575	V
DDR IO (DDR3L mode) Power	DDR_VDD	1.283	1.35	1.417	V
PLL Digital Power	PLL_AVDD_1V0	0.9	1.0	1.1	V
PLL Analog Power	PLL_AVDD_1V8	1.62	1.8	1.98	V
ACODEC Analog Power	CODEC_AVDD_1V8	1.62	1.8	1.98	V
VDAC Analog Power	VDAC_AVDD_1V8	1.62	1.8	1.98	V
USB OTG/Host2.0 Digital Power	USB_AVDD_1V0	0.9	1.0	1.1	V
USB OTG/Host2.0 Analog Power(1.8V)	USB_AVDD_1V8	1.62	1.8	1.98	V
USB OTG/Host2.0 Analog Power(3.3V)	USB_AVDD_3V3	3.069	3.3	3.63	V
HDMI Analog Power(1.0V)	HDMI_AVDD_1V0	0.9	1.0	1.1	V
HDMI Analog Power(1.8V)	HDMI_AVDD_1V8	1.62	1.8	1.98	V
SARADC Analog Power(1.8V)	SADC_AVDD_1V8	1.62	1.8	1.98	V
TSADC Analog Power(1.8V)	SADC_AVDD_1V8	1.62	1.8	1.98	V
MIPI DSI Analog Power(1.0V)	MIPI_DSI_AVDD_1V0	0.9	1.0	1.1	V
MIPI DSI Analog Power(1.8V)	MIPI_DSI_AVDD_1V8	1.62	1.8	1.98	V
MIPI CSI Analog Power(1.0V)	MIPI_CSI_AVDD_1V0	0.9	1.0	1.1	V
VIDEOADC Analog Power(1.0V)	VIDEO_AVDD_1V0	0.9	1.0	1.1	V
VIDEOADC Analog Power(1.8V)	VIDEO_AVDD_1V8	1.62	1.8	1.98	V
PLL input clock frequency		N/A	24	N/A	MHz
Operating Temperature		-40	25	125	°C

3.3 DC Characteristics

Table 3-3 RK1108 DC Characteristics

Parameters		Symbol	Min	Typ	Max	Units
Digital GPIO @3.3V	Input Low Voltage	Vil	-0.3	0	3.3x0.3	V
	Input High Voltage	Vih	3.3x0.7	3.3	3.3+0.3	V
	Output Low Voltage	Vol	-0.3	NA	NA	V
	Output High Voltage	Voh	NA	NA	3.6	V
	Threshold Point	Vtr+	1.53	1.46	1.43	V
		Vtr-	1.19	1.12	1.05	V
	Pullup Resistor	Rpu	33.7	58	101.5	Kohm
Pulldown Resistor	Rpd	34.2	60.1	109.3	Kohm	
Digital GPIO @1.8V	Input Low Voltage	Vil	-0.3	0	1.8x0.3	V
	Input High Voltage	Vih	1.8x0.7	1.8	1.8 + 0.3	V
	Output Low Voltage	Vol	-0.3	NA	NA	V
	Output High Voltage	Voh	NA	NA	1.8+0.3	V
	Threshold Point	Vtr+	1.23	1.12	1.03	V
		Vtr-	0.91	0.82	0.73	V
	Pullup Resistor	Rpu	35	62.9	120	Kohm
Pulldown Resistor	Rpd	35.1	61	113.9	Kohm	
DDR IO @DDR3 mode	Input High Voltage	Vih_dds	VREF + 0.10	NA	DDR_VDD+0.4	V
	Input Low Voltage	Vil_dds	-0.4	NA	VREF - 0.10	V
	Output High Voltage	Voh_dds	0.9xDDR_VDD	NA	N/A	V
	Output Low Voltage	Vol_dds	N/A	NA	0.1*DDR_VDD	V
	Input termination resistance(ODT) to VDDIO_DDRi/2 (i=0~6)	Rtt	100 54 36	120 60 40	140 66 44	Ohm
HDMI	Single-ended standby voltage	Voff	avddtmds±10			mV
	Single-ended output swing voltage RT=50Ω	Vswing	400		600	mV
		Vswing_data	400		600	mV
		Vswing_clock	400		600	mV
	Single-ended output high voltage	Vh	avddtmds-400		avddtmds+10	mV
		Vh_data	avddtmds-400		avddtmds+10	mV
		Vh_clock	avddtmds-400		avddtmds+10	mV
	Single-ended output low voltage	VI				mV
		VI_data	avddtmds-1000		avddtmds-400	mV
		VI_data	avddtmds-1000		avddtmds-400	mV

Parameters		Symbol	Min	Typ	Max	Units
					00	
		VI_clock	avddtmds-100 0		avddtmds-4 00	mV
	Differential source termination load	Rterm	75		150	Ω
MIPI DSI MIPI mode	HS TX static common-mode	Vcmtx	150	200	250	mV
	Vcmtx mismatch when output is Differential-1 or Differential-0	ΔVcmtx(1, 0)			5	mV
	HS Transmit differential voltage	Vod	140	200	270	mV
	Vod mismatch when output is Differential-1 or Differential-0	ΔVod			10	mV
	HS output high voltage	Vohhs			360	mV
	Single ended output impedance	Zos	40	50	62.5	Ohm
	Single ended output impedance mismatch	ΔZos			10	%
MIPI DSI LP mode	The venin output high level	Voh	0.9	1	1.1	V
	The venin output low level	Vol	-50		50	mV
	Output impedance of LP	Zolp	110			Ω
MIPI DSI CMOS mode	High-level output voltage	Voh	3	3.3		V
	Low-level output voltage	Vol		0	0.2	V
	Output impedance	Zolp	40		460	Ω
MIPI CSI MIPI mode	Common-mode voltage HS receive mode	Vcmrx(dc)	70		300	mV
	Differential input high threshold	Vidth			70	mV
	Differential input low threshold	Vidtl	-70			mV
	Single-ended input high voltage	Vihhs			460	mV
	Single-ended input low voltage	Vilhs	-40			mV
	Single-ended threshold for HS termination enable	Vterm-en			450	mV
	Differential input impedance	Zid	80	100	125	Ω
MIPI CSI LP mode	Logic 1 input voltage	Vih	880			mV
	Logic 0 input voltage, not in ULP state	Vil			550	mV
	Logic 0 input voltage, ULP state	Vil-ulps			300	mV
	Input hysteresis	Vhyst	25			mV
SARADC	Effective Number of Bit	ENOB		9		Bit
	Differential Nonlinearity	DNL	-1		+1	LSB
	Integral Nonlinearity	INL	-2		+2	LSB
	Input Voltage Range	Vin	0		1	AVDD
	Input Capacitance	Cin		10		pF

Parameters		Symbol	Min	Typ	Max	Units	
	Sampling rate	fs			1	MS/s	
	Spurious Free Dynamic Range	SFDR		61		dB	
	Signal to Noise and Harmonic Ratio	SNDR		56		dB	
CODEC	Microphone Bias	Vmicb	0.5 * AVDD		0.85 * AVDD	V	
		Imicb			3	mA	
	Microphone Gain Boost PGA	Gbst	0		20	dB	
		Cin		10		pF	
	ALC PGA	Galc	-18		28.5	dB	
	ADC	SNR			92	dB	
		THD			-81	dB	
	DAC Output Driver	Gdrv	-39			6	dB
		Rout			1		Ω
		Cout			20		pF
PSRR				70			

3.4 Recommended Operating Frequency

Table 3-4 Recommended operating frequency for bus domain

Parameter	Condition	Symbol	Min	Typ	Max	Unit
DDR PLL	1.0V , 25 °C	ddr_pll_clk				MHz
	1.1V , -40 °C					
	0.9V , 125 °C				1600	
ARM PLL	1.0V , 25 °C	arm_pll_clk				MHz
	1.1V , -40 °C					
	0.9V , 125 °C				800	
GENERAL PLL	1.0V , 25 °C	general_pll_clk				MHz
	1.1V , -40 °C					
	0.9V , 125 °C				1200	
BUS AXI interconnect	1.0V , 25 °C	aclk_bus				MHz
	1.1V , -40 °C					
	0.9V , 125 °C				300	
	1.0V , 25 °C	hclk_bus				MHz
	1.1V , -40 °C					
	0.9V , 125 °C				150	
	1.0V , 25 °C	pclk_bus				MHz
	1.1V , -40 °C					
	0.9V , 125 °C				75	
DMC	1.0V , 25 °C	clk_dds				MHz
	1.1V , -40 °C					
	0.9V , 125 °C				400	
CRYPTO	1.0V , 25 °C	clk_crypto				MHz
	1.1V , -40 °C					
	0.9V , 125 °C				150	
I2S	1.0V , 25 °C	mclk_i2s				MHz
	1.1V , -40 °C					
	0.9V , 125 °C				50	
SARADC	1.0V , 25 °C	clk_saradc				MHz

Parameter	Condition	Symbol	Min	Typ	Max	Unit
	1.1V , -40 °C					
	0.9V , 125 °C				24	
I2C	1.0V , 25 °C	clk_i2c				MHz
	1.1V , -40 °C					
	0.9V , 125 °C				100	
	1.0V , 25 °C	clk_timer				MHz
1.1V , -40 °C						
	0.9V , 125 °C				24	
	1.0V , 25 °C	clk_spi				MHz
1.1V , -40 °C						
	0.9V , 125 °C				100	
	1.0V , 25 °C	clk_tsadc				MHz
1.1V , -40 °C						
	0.9V , 125 °C				24	
	1.0V , 25 °C	clk_uart				MHz
1.1V , -40 °C						
	0.9V , 125 °C				100	

Table 3-5 Recommended operating frequency for CORE

Parameter	Condition	Symbol	Min	Typ	Max	Unit	
Cortex-A7	1.0V , 25 °C	clk_core				MHz	
	1.1V , -40 °C						
	0.9V , 125 °C				800		
		1.0V , 25 °C	aclk_core				MHz
		1.1V , -40 °C					
		0.9V , 125 °C				400	
		1.0V , 25 °C	pclk_dbg				MHz
		1.1V , -40 °C					
		0.9V , 125 °C				200	

Table 3-6 Recommended operating frequency for DSP

Parameter	Condition	Symbol	Min	Typ	Max	Unit	
DSP	1.0V , 25 °C	clk_dsp				MHz	
	1.1V , -40 °C						
	0.9V , 125 °C				450		
		1.0V , 25 °C	aclk_dsp				MHz
		1.1V , -40 °C					
		0.9V , 125 °C				225	
		1.0V , 25 °C	pclk_dsp				MHz
		1.1V , -40 °C					
		0.9V , 125 °C				75	

Table 3-7 Recommended operating frequency for PERI domain

Parameter	Condition	Symbol	Min	Typ	Max	Unit
-----------	-----------	--------	-----	-----	-----	------

Parameter	Condition	Symbol	Min	Typ	Max	Unit	
PERI AXI interconnect	1.0V , 25 °C	aclk_periph				MHz	
	1.1V , -40 °C						
	0.9V , 125 °C				300		
	PERI AXI interconnect	1.0V , 25 °C	hclk_periph				MHz
		1.1V , -40 °C					
		0.9V , 125 °C				150	
	PERI AXI interconnect	1.0V , 25 °C	pclk_periph				MHz
		1.1V , -40 °C					
		0.9V , 125 °C				75	
NANDC	1.0V , 25 °C	clk_nandc				MHz	
	1.1V , -40 °C						
	0.9V , 125 °C				150		
SDMMC	1.0V , 25 °C	clk_sdmmc				MHz	
	1.1V , -40 °C						
	0.9V , 125 °C				100		
SDIO	1.0V , 25 °C	clk_sdio				MHz	
	1.1V , -40 °C						
	0.9V , 125 °C				300		
EMMC	1.0V , 25 °C	clk_emmc				MHz	
	1.1V , -40 °C						
	0.9V , 125 °C				200		
SFC	1.0V , 25 °C	clk_sfc				MHz	
	1.1V , -40 °C						
	0.9V , 125 °C				100		
GMAC	1.0V , 25 °C	clk_gmac				MHz	
	1.1V , -40 °C						
	0.9V , 125 °C				50		

Table 3-8 Recommended operating frequency for RKVENC domain

Parameter	Condition	Symbol	Min	Typ	Max	Unit	
RKVENC	1.0V , 25 °C	aclk_rkvenc				MHz	
	1.1V , -40 °C						
	0.9V , 125 °C				300		
	RKVENC	1.0V , 25 °C	clk_rkvenc				MHz
		1.1V , -40 °C					
		0.9V , 125 °C				300	
	RKVENC	1.0V , 25 °C	hclk_rkvenc				MHz
		1.1V , -40 °C					
0.9V , 125 °C					75		

Table 3-9 Recommended operating frequency for RKVDEC domain

Parameter	Condition	Symbol	Min	Typ	Max	Unit
RKVDEC	1.0V , 25 °C	aclk_rkvdec				MHz
	1.1V , -40 °C					
	0.9V , 125 °C				300	

Parameter	Condition	Symbol	Min	Typ	Max	Unit
	1.0V , 25 °C	hclk_rkvdec				MHz
	1.1V , -40 °C					
	0.9V , 125 °C				75	
	1.0V , 25 °C	clk_rkvdec				MHz
	1.1V , -40 °C					
	0.9V , 125 °C				75	
VPU	1.0V , 25 °C	aclk_vpu				MHz
	1.1V , -40 °C					
	0.9V , 125 °C				400	
	1.0V , 25 °C	hclk_vpu				MHz
	1.1V , -40 °C					
	0.9V , 125 °C				75	

Table 3-10 Recommended operating frequency for VIO

Parameter	Condition	Symbol	Min	Typ	Max	Unit
VIO interconnect	1.0V , 25 °C	aclk_vio				MHz
	1.1V , -40 °C					
	0.9V , 125 °C				300	
	1.0V , 25 °C	hclk_vio				MHz
	1.1V , -40 °C					
	0.9V , 125 °C				75	
	1.0V , 25 °C	pclk_vio				MHz
	1.1V , -40 °C					
0.9V , 125 °C				75		
RGA	1.0V , 25 °C	clk_rga				MHz
	1.1V , -40 °C					
	0.9V , 125 °C				300	
CIF0/1/2/3	1.0V , 25 °C	pclk_vip0/1/2/3				MHz
	1.1V , -40 °C					
	0.9V , 125 °C				150	
ISP	1.0V , 25 °C	clk_isp				MHz
	1.1V , -40 °C					
	0.9V , 125 °C				400	
VOP	1.0V , 25 °C	dclk_vop				MHz
	1.1V , -40 °C					
	0.9V , 125 °C				150	
TV Decoder	1.0V , 25 °C	clk_cvbs				MHz
	1.1V , -40 °C					
	0.9V , 125 °C				54	
HDMI Host	1.0V , 25 °C	ipixelclk				MHz
	1.1V , -40 °C					
	0.9V , 125 °C				150	
	1.0V , 25 °C	ii2sclk				MHz
	1.1V , -40 °C					

Parameter	Condition	Symbol	Min	Typ	Max	Unit
	0.9V , 125 °C				50	
MIPI DSI Host	1.0V , 25 °C	dpipeclk				MHz
	1.1V , -40 °C					
	0.9V , 125 °C				150	

3.5 Electrical Characteristics for General IO

Table 3-11 RK1108 Electrical Characteristics for Digital General IO

Parameters		Symbol	Test condition	Min	Typ	Max	Units
Digital GPIO @3.3V	Input leakage current	Ii	Vin = 3.3V or 0V	NA	NA	10	uA
	Tri-state output leakage current	Ioz	Vout = 3.3V or 0V	NA	NA	10	uA
	High level input current	Iih	Vin = 3.3V, pulldown disabled	NA	NA	10	uA
			Vin = 3.3V, pulldown enabled	NA	NA	106.4	uA
	Low level input current	Iil	Vin = 0V, pullup disabled	NA	NA	10	uA
			Vin = 0V, pullup enabled	NA	NA	107.8	uA
Digital GPIO @1.8V	Input leakage current	Ii	Vin = 1.8V or 0V	NA	NA	10	uA
	Tri-state output leakage current	Ioz	Vout = 1.8V or 0V	NA	NA	10	uA
	High level input current	Iih	Vin = 1.8V, pulldown disabled	NA	NA	10	uA
			Vin = 1.8V, pulldown enabled	NA	NA	61.3	uA
	Low level input current	Iil	Vin = 0V, pullup disabled	NA	NA	10	uA
			Vin = 0V, pullup enabled	NA	NA	61.4	uA

3.6 Electrical Characteristics for PLL

Table 3-12 RK1108 Electrical Characteristics for PLL

Parameters		Symbol	Test condition	Min	Typ	Max	Units
PLL	Input clock frequency(Int)	F _{in}	F _{in} = FREF @3.3V/1.1V	1		800	MHz
	Input clock frequency(Frac)	F _{in}	F _{in} = FREF @3.3V/1.1V	10		800	MHz
	VCO operating range	F _{vco}	F _{vco} = Fref * FBDIV @3.3V/1.1V	800		3200	MHz
	Output clock frequency	F _{out}	F _{out} = Fvco/POSTDIV @3.3V/1.1V	16		3200	MHz
	Lock time	T _{lt}	@ 3.3V/1.1V, FREF=24M,REFDIV=1		250	500	Input clock cycles
	VDDHV current consumption		Fvco = 1000MHz, @3.3V Current scale as (Fvco/1GHz)^{1.5}		1.0	1.2	mA
	VDD Current consumption		VDD =1.1V		1.3	1.56	uA/MHz
	Power consumption (power-down mode)		PD=HIGH, @27 °C		13		uA

Notes :

REFDIV is the input divider value;
 FBDIV is the feedback divider value;
 POSTDIV is the output divider value

3.7 Electrical Characteristics for USB Interface

Table 3-13 RK1108 Electrical Characteristics for USB Interface

Parameters	Symbol	Test condition	Min	Typ	Max	Units
Transmitter						
High input level	VIH		NA	1.0	NA	V
Low input level	VIL		NA	0	NA	V
Output resistance	ROUT	Classic mode (Vout = 0 or 3.3V)	40.5	45	49.5	ohms
		HS mode (Vout = 0 to 800mV)	40.5	45	49.5	ohms
Output Capacitance	COUT	seen from D+ or D-			3	pF
Output Common Mode Voltage	VM	Classic (LS/FS) mode	1.45	1.65	1.85	V
		HS mode	0.175	0.2	0.225	V
Differential output signal high	VOH	Classic (LS/FS); Io=0mA	2.97	3.3	3.63	V
		Classic (LS/FS); Io=6mA	2.2	0.3	NA	V
		HS mode; Io=0mA	360	400	440	mV
Differential output signal low	VOL	Classic (LS/FS); Io=0mA	-0.33	0	0.33	V
		Classic (LS/FS); Io=6mA	NA	0.3	0.8	V
		HS mode; Io=0mA	-40	0	40	mV
Receiver						
Receiver sensitivity	RSENS	Classic mode		+250		mV
		HS mode		+25		mV
Receiver common mode	RCM	Classic mode	0.8	1.65	2.5	V
		HS mode (differential and squelch comparator)	0.1	0.2	0.3	V
		HS mode (disconnect comparator)	0.5	0.6	0.7	V
Input capacitance (seen at D+ or D-)			NA	NA	3	pF
Squelch threshold			100	112	150	mV
Disconnect threshold			570	590	625	mV
High output level	VOH		NA	3.3	NA	V
Low output level	VOL		NA	0	NA	V

3.8 Electrical Characteristics for DDR IO

Table 3-13 RK1108 Electrical Characteristics for DDR IO

Parameters		Symbol	Test condition	Min	Typ	Max	Units
DDR IO @DDR3 mode	Input leakage current, SSTL mode, unterminated		@ 1.5V , 125°C	NA	0		uA
DDR IO @DDR3L mode	Input leakage current		@ 1.35V , 125°C	NA	0	NA	nA

3.9 Electrical Characteristics for eFuse

Table 3-14 RK1108 Electrical Characteristics for eFuse

	Parameters	Symbol	Test condition	Min	Typ	Max	Units
Active mode	VDD current in Read mode	Iread_vdd	nomal read	15	20	30	mA
	VDD current in PGM mode	Ipgm_vdd	STROBE high	0.5	1	2.5	mA
	VQPS current in PGM mode	Ipgm_vqps	STROBE high	5	10	15	mA
standby mode	VDD current in standby mode	Istandby_vdd	Standby	0.2	0.5	2	A

3.10 Electrical Characteristics for HDMI

Table 3-15 RK1108 Electrical Characteristics for HDMI

Parameters	Symbol	Test condition	Min	Typ	Max	Units
Trise and Tfall				<200		ps
Frequency Tolerance, max				-300 ~300		ppm
Clock duty cycle			40%		60%	
Power consumption		1080p		60		mA
Power consumption		2160p		100		mA

3.11 Electrical Characteristics for VDAC

Table 3-16 RK1108 Electrical Characteristics for VDAC

Parameters	Symbol	Test condition	Min	Typ	Max	Units
Analog Supply	AVDD		1.62	1.8	1.98	V
Digital Supply	VDD		0.9	1.0	1.1	V
Junction Temperature	Tj		-40		125	°C
Output Resistance	R _{OUT}			50		KΩ
Output Capacitance	C _{OUT}			10		pF
Full Scale Output Current	I _{OUT}		14.7		34.8	mA
Resistance Load	R _L			75		Ω
Clock Frequency	f _{CLK}				300	MHz
Analog Supply Current	I _{AVDD}	I _{OUT} =14.7mA		18		mA
		I _{OUT} =34.8mA		39		mA
		Power Down		10		uA
Digital Supply Current	I _{VDD}	f _{CLK} =100MHz		100		uA
		Power Down		1		uA

3.12 Electrical Characteristics for TSADC

Table 3-17 RK1108 Electrical Characteristics for TSADC

Parameters	Symbol	Test condition	Min	Typ	Max	Units
Temperature Resolution				5		°C
Temperature Range			-40		125	°C
Analog power	I _{AVDD}	F _s = 50KS/s		190		uA
Digital power	I _{VDD}	F _s = 50KS/s		10		uA
Clock Frequency	F _{clk}	F _{clk}			800	KHz
Power Down Current from Analog	I _{AVDD}	Power down		1		uA
Power Down Current from Digital	I _{VDD}	Power down		1		uA

3.13 Electrical Characteristics for MIPI DSI

Table 3-18 RK1108 Electrical Characteristics for MIPI DSI

Parameters	Symbol	Test condition	Min	Typ	Max	Units
HS TX static common-mode	V _{cmx}		150	200	250	mV
V _{cmx} mismatch when output is Differential-1 or Differential-0	ΔV _{cmx(1,0)}				5	mV
HS Transmit differential voltage	V _{od}		140	200	270	mV
V _{od} mismatch when output is Differential-1 or Differential-0	ΔV _{od}				10	mV
HS output high voltage	V _{ohs}				360	mV
Single ended output impedance	Z _{os}		40	50	62.5	Ohm
Single ended output impedance mismatch	ΔZ _{os}				10	%
The venin output high level	V _{oh}		0.9	1	1.1	V
The venin output low level	V _{ol}		-50		50	mV
Output impedance of LP	Z _{olp}		110			Ω
High-level output voltage	V _{oh}		3	3.3		V
Low-level output voltage	V _{ol}			0	0.2	V
Output impedance	Z _{olp}		40		460	Ω
Common-mode variations above 450 MHz	ΔV _{cmx(HF)}				15	mV _{rms}
Common-mode variations between 50MHz - 450MHz	ΔV _{cmx(LF)}					mV _{peak}
20%-80% rise time and fall time	T _r and T _f				0.3	UI
			150			ps
Maximum data rate	D _{max}			200		Mbit/s
15%-85% rise time and fall time	T _{rlp} /T _{flp}		1	1.5	2	ns
Slew rate, transition region	SR		20	27	30	V/ns

3.14 Electrical Characteristics for MIPI CSI

Table 3-19 RK1108 Electrical Characteristics for MIPI CSI

Parameters	Symbol	Test condition	Min	Typ	Max	Units
Common-mode voltage HS receive mode	Vcmrx(dc)		70		300	mV
Differential input high threshold	Vidth				70	mV
Differential input low threshold	Vidtl		-70			mV
Single-ended input high voltage	Vihhs				460	mV
Single-ended input low voltage	Vilhs		-40			mV
Single-ended threshold for HS termination enable	Vterm-en				450	mV
Differential input impedance	Zid		80	100	125	Ω
Logic 1 input voltage	Vih		880			mV
Logic 0 input voltage, not in ULP state	Vil				550	mV
Logic 0 input voltage, ULP state	Vil-ulps				300	mV
Input hysteresis	Vhyst		25			mV
Common-mode interference beyond 450 MHz	$\Delta V_{cmrx}(HF)$				100	mV
Common-mode interference 50MHz-450MHz	$\Delta V_{cmrx}(LF)$		-50		50	mV
Common-mode termination	Ccm				60	pF
Input pulse rejection	Espike				300	V.ps
Minimum pulse width response	Tmin-rx		20			ns
Peak interference amplitude	Vint				200	mV
Interference frequency	Fint		450			MHz

3.15 Electrical Characteristics for SARADC

Table 3-20 RK1108 Electrical Characteristics for SARADC

Parameters	Symbol	Test condition	Min	Typ	Max	Units
Analog Supply	AVDD		1.62	1.8	1.98	V
Digital Supply	VDD		0.9	1.0	1.1	V
Junction Temperature	Tj		-40	-	125	$^{\circ}\text{C}$
Effective Number of Bit	ENOB			9		Bit
Differential Nonlinearity	DNL		-1		+1	LSB
Integral Nonlinearity	INL		-2		+2	LSB
Input Voltage Range	Vin		0		1	AVDD

Parameters	Symbol	Test condition	Min	Typ	Max	Units
Input Capacitance	Cin			10		pF
Sampling rate	fs				1	MS/s
Spurious Free Dynamic Range	SFDR	Fs=1MS/s Fout=1.17KHz		61		dB
Signal to Noise and Harmonic Ratio	SNDR			56		dB
Analog Supply Current	IAVDD	Fs=1MS/s		450		uA
		Power Down		1		uA
Digital Supply Current	IVDD	Fs=1MS/s		50		uA
		Power Down		1		uA

3.16 Electrical Characteristics for ACODEC

Table 3-21 RK1108 Electrical Characteristics for ACODEC

Parameters	Symbol	Test condition	Min	Typ	Max	Units
Analog Supply	AVDD		1.62	1.8	1.98	V
Digital Supply	DVDD		0.9	1.0	1.1	V
Junction Temperature	Tj		-40		125	°C
Bias Voltage	VMICB		0.5 * AVDD		0.85 * AVDD	V
Bias Voltage	IMICB				3	mA
Programmable Gain	GBST		0		20	dB
Input Resistance	RIN	GBST=0dB		110		KΩ
		GBST=20dB		20		KΩ
Input Capacitance	CIN			10		pF
Programmable Gain	GALC		-18		28.5	dB
Signal to Noise Ratio	SNR	A-weighted		92		dB
Total Harmonic Distortion	THD	-3dBFS input		-81		dB
Programmable Gain	GDRV		-39		6	dB
Output Resistance	ROUT			1		Ω
Output Capacitance	COUT			20		pF
Power Supply Rejection	PSRR	1KHz		70		dB
Signal to Noise Ration	SNR	A-weighted		93		dB
Total Harmonic Distortion	THD	-3dBFS output 600Ω load		-80		dB

3.17 Electrical Characteristics for VIDEO ADC

Table 3-22 RK1108 Electrical Characteristics for VIDEO ADC

Parameters	Symbol	Test condition	Min	Typ	Max	Units
Max Current	I _{max}			800		uA

Parameters	Symbol	Test condition	Min	Typ	Max	Units
Min Current	I_{min}			50		uA
Current Consumption	I_{sup}			1		uA
Total Harmonic Distortion AGC setting 101010=0dB V_{in} : mV _{pp}	THD _N	$F_{sig}=5.5\text{MHZ}$		-72	-65	dB
		$F_{sig}=5.5\text{MHZ}$		-61	-56	dB
		$F_{sig}=88\text{MHZ}$		-60	-49	dB
BW in bypass	BW_{bp}			200	100	MHz
Output noise	N_{int}			725		uV
Current Consumption	I_{buff}			9.4		mA
	I_{agc}			4.25		mA
	I_{filter}			4.25		mA
Total Power Consumption	I_{sup}			18		mA
Resolution	Res			10		Bit
Sampling Frequency	F_s			50	60	MHz
Input Voltage for Full Scale	V_{in}			1		V _{pp}
Input Common Mode	V_{CM}			0.5		V
Differential Input Capacitance	C_{in_diff}			2		pF
Single ended input capacitance	C_{in_cm}			3		pF
Current Consumption	I_{sup}	$V_{dd}=1.1\text{V}$		45		mA