

# Rockchip RK3528A Datasheet

## Revision History

Date	Revision	Description
2025-05-12	1.4	Update the USB description in the 1.3 block diagram
2024-12-30	1.3	Add the part number RK3528A-D in Chapter 2; Update the GPU description (delete "MP2")
2024-04-10	1.2	Update the description about HDMI and LPDDR4X
2024-01-03	1.1	Update the description about DDR and USB
2023-07-12	1.0	Initial release

## Table of Content

Table of Content .....	2
Figure Index .....	3
Table Index.....	4
Warranty Disclaimer.....	5
Chapter 1 Introduction .....	5
1.1 Overview .....	6
1.2 Features .....	6
1.3 Block Diagram .....	15
Chapter 2 Package Information.....	16
2.1 Order Information .....	16
2.2 Top Marking .....	16
2.3 Package Dimension .....	17
2.4 MSL Information .....	19
2.5 Lead Finish/Ball Material Information .....	19
2.6 Pin Number List .....	19
Chapter 3 Electrical Specification .....	25
3.1 Absolute Ratings .....	25
3.2 Recommended Operating Conditions .....	25
3.3 DC Characteristics .....	26
3.4 Electrical Characteristics for General IO .....	26
3.5 Electrical Characteristics for PLL .....	27
3.6 Electrical Characteristics for USB2.0 Interface .....	27
3.7 Electrical Characteristics for HDMI .....	28
3.8 Electrical Characteristics for Audio CODEC interface .....	28
3.9 Electrical Characteristics for SARADC .....	29
3.10 Electrical Characteristics for TSADC.....	29
Chapter 4 Thermal Management.....	30
4.1 Overview .....	30
4.2 Package Thermal Characteristics .....	30

**Figure Index**

Fig.1-1 Block Diagram ..... 15  
Fig.2-1 RK3528A Package definition ..... 16  
Fig.2-2 RK3528A-D Package definition ..... 16  
Fig.2-3 Package Top View ..... 17  
Fig.2-4 Package Bottom View ..... 18  
Fig.2-5 Package Side View ..... 18  
Fig.2-6 Package Dimension ..... 19

Rockchip Confidential

**Table Index**

Table 2-1 Pin Number Order Information ..... 19

Table 3-1 Absolute Ratings ..... 25

Table 3-2 Recommended Operating Conditions ..... 25

Table 3-3 DC Characteristics ..... 26

Table 3-4 Electrical Characteristics for Digital General IO ..... 26

Table 3-5 Electrical Characteristics for INT PLL ..... 27

Table 3-6 Electrical Characteristics for FRAC PLL ..... 27

Table 3-7 Electrical Characteristics for USB2.0 Interface ..... 27

Table 3-8 Electrical Characteristics for HDMI ..... 28

Table 3-9 Electrical Characteristics for Audio CODEC ..... 28

Table 3-10 Electrical Characteristics for SARADC ..... 29

Table 3-11 Electrical Characteristics for TSADC ..... 29

Table 4-1 Thermal Resistance Characteristics ..... 30

Rockchip Confidential

## Warranty Disclaimer

Copyright © 2025 Rockchip Electronics Co., Ltd. All rights reserved.

No part of this document may be reproduced, transmitted or used in any form or by any means without the written prior consent of Rockchip Electronics Co., Ltd.

### Trademark

Rockchip is a registered trademark of Rockchip Electronics Co., Ltd. in the People's Republic of China and other countries/areas. Other brands, product names mentioned in this document are the property of their respective owners.

### Disclaimer

Rockchip Electronics Co., Ltd. ("Rockchip") may make changes to any information in this document at any time without any prior notice.

Information in this document is provided just as a reference or typical applications. All or part of product features described in this document may not be within the purchase scope or the usage scope, and may be subject to the third party licensing requirements. All statements, information in this document is provided "AS IS" without warranties of any kind, either express or implied. Actual performance of Rockchip products may vary in different applications. Third party licenses maybe required to use some features supported by Rockchip products. Customers shall be solely and exclusively responsible to obtain all appropriately required third party licenses prior to its such use. Should customers use the features supported by Rockchip products without any required third party license, customers shall indemnify and hold Rockchip and its subsidiaries, affiliates as well as distributors harmless against all claims, costs, damages, and expenses, and reasonable attorney fees arising out of any claim associated with such unauthorized use.

Rockchip products are not intended for use in military, airplane, medical devices, lifesaving or life sustaining applications ("Unintended Uses"). Customers shall take any and all actions to ensure using Rockchip products in a lawful manner and shall be liable for Unintended Uses.

## Chapter 1 Introduction

### 1.1 Overview

RK3528A is a high performance Quad-core application processor designed for Smart IPTV/OTT/DBS and high-end multimedia application. It is a high integration and cost efficient SOC for 4K video application.

Quad-core Cortex-A53 is integrated with separate Neon and FPU coprocessor, also with shared L2 Cache to enhance system performance.

ARM Mali-450 GPU supports high-resolution display and game. It handles graphics programs like OpenGL ES1.1/2.0, OpenVG.

Dedicated ARM TrustZone based secure system to handle safety management for video and display applications. It includes crypto, rng, firewall engine to guarantee the whole system's security.

32-bit DRAM interface providing high bandwidth DDR3(L)/LPDDR3/DDR4/LPDDR4 support.

The advanced video decoder supports 60fps playback of 4K ultra-high-definition video with up to 10-bit pixels. It supports H.265, H.264, AVS2, etc. video standards.

The advanced video encoder also supports 60fps capture of 1080p high-definition video. It supports H.265 and H.264 encoding.

Display controller supports flexible surface and output stream. Outputs include two outputs switchable between HDMI 2.0 transmitter with HDR, CEC, HDCP2.2 support and CVBS.

In addition to these major elements, RK3528A processors have a broad range of peripheral interfaces like pcie2, usb2, mac, i2s, etc. to enable communication with wireless baseband, other communications peripherals, audio codec, power management, and mass storage.

### 1.2 Features

#### 1.2.1 Application Processor

- Quad core ARM Cortex-A53
- Full implementation of the ARM v8-A architecture.
- Separately Integrated Neon and FPU
- TrustZone Extension support
- One isolated voltage domain to support DVFS

#### 1.2.2 Graphic Processor

- ARM Mali-450 GPU
- Concurrent multi-core processing
- Separate vertex(geometry) and fragment(pixel) processing for maximum parallel throughput
- OpenGL ES 1.1/2.0 and OpenVG 1.1 support
- One isolated voltage domain to support DVFS

#### 1.2.3 Memory Organization

- Internal on-chip memory
  - BootRom
    - ◆ Support system boot from the following device:
      - SPI interface
      - eMMC interface
      - SD/MMC interface
    - ◆ Support system code download by the following interface:

- USB interface
  - 64KB Share Memory
  - 8KB PMU SRAM
- External off-chip memory
  - eMMC Interface
    - ◆ Fully compliant with JEDEC eMMC5.1 specification
    - ◆ Support HS400, support CMD Queue
    - ◆ Support three data bus width: 1bit, 4bits or 8bits
  - SD/MMC Interface
    - ◆ Compatible with SD3.0, MMC ver4.51
    - ◆ Data bus width is 4bits
  - Flexible Serial Flash Interface (FSPI)
    - ◆ Support transfer data from/to serial flash device
    - ◆ Support 1bit, 2bits or 4bits data bus width
- Dynamic Memory Interface : DDR3(L)/LPDDR3/DDR4/LPDDR4/LPDDR4X
  - Compatible with JEDEC standard DDR3-2133/DDR3L-2133/LPDDR3-2133/DDR4-2400/LPDDR4(X)-2400 SDRAM
  - Supports 32 Bits data width, 4GB addressing space

### 1.2.4 System Component

- MCU
  - Cortex-M0 in PMU domain integrate 8KB TCM.
  - Integrated Debug Controller with JTAG interface
- CRU (clock & reset unit)
  - Support total 5 PLLs to generate all clocks
  - One oscillator with 24MHz clock input
  - Support clock gating control for individual components
  - Support global soft-reset control for whole chip, also individual soft-reset for each component
- PMU (power management unit)
  - Multiple configurable work modes to save power by different frequency or automatic clock gating control or power domain on/off control
  - Lots of wakeup sources in different mode
  - Support 4 separate voltage domains, VDD\_ARM,VDD\_GPU,VDD\_LOGIC,VDD\_PMU.
- Timer
  - Support 2 secure timers with 64bits counter and interrupt-based operation
  - Support 6 non-secure timers with 64bits counter and interrupt-based operation
  - Support 1 high precision timer.
  - Support two operation modes: free-running and user-defined count for each timer
  - Support timer work state checkable
- PWM
  - Support 8 on-chip PWMs (PWM0~PWM7) with interrupt-based operation
  - Programmable pre-scaled operation to bus clock and then further scaled
  - Embedded 32-bit timer/counter facility
  - Support capture mode
  - Support continuous mode or one-shot mode
  - Provides reference mode and output various duty-cycle waveform
  - Optimized for IR application for PWM3, PWM7
- Watchdog
  - 32-bit watchdog counter
  - Counter counts down from a preset value to 0 to indicate the occurrence of a timeout
  - WDT can perform two types of operations when timeout occurs:

- ◆ Generate a system reset
- ◆ First generate an interrupt and if this is not cleared by the service routine by the time a second timeout occurs then generate a system reset
- One Watchdog for non-secure application
- One Watchdog for secure application
- One Watchdog for MCU
- Interrupt Controller
  - Support 256 SPI interrupt sources input from different components inside RK3528A
  - Support 16 software-triggered interrupts
  - Input interrupt level is fixed, high-level sensitive or rising edge sensitive
  - Support different interrupt priority for each interrupt source, and they are always software-programmable
- DMAC
  - Micro-code programming-based DMA
  - Linked list DMA function is supported to complete scatter-gather transfer
  - Support data transfer types including memory-to-memory, memory-to-peripherals, peripherals-to-memory
  - Totally three embedded DMA controllers for peripheral system
  - Each DMAC features:
    - ◆ Support 8 channels
    - ◆ 32 hardware requests from peripherals
    - ◆ 2 interrupt output
    - ◆ Support TrustZone technology and programmable secure state for each DMA channel
- Secure System
  - Embedded one cipher engines
    - ◆ Support Link List Item (LLI) DMA transfer
    - ◆ Support SHA-1, SHA-256/224, MD5, SM3 with hardware padding
    - ◆ Support HMAC of SHA-1, SHA-256, MD5, SM3 with hardware padding
    - ◆ Support AES-128, AES-192, AES-256 encrypt and decrypt cipher
    - ◆ Support DES and TDES cipher
    - ◆ Support AES ECB/CBC/OFB/CFB/CTR/CTS/XTS/GCM/CBC-MAC/CMAC mode
    - ◆ Support SM4 ECB/CBC/OFB/CFB/CTR/CTS/XTS/GCM/CBC-MAC/CMAC mode
    - ◆ Support DES/TDES ECB/CBC/OFB/CFB mode
    - ◆ Support up to 4096 bits PKA mathematical operations for RSA
  - Support generating random numbers, one secure only engine, another one security configurable
  - Support secure OTP
  - Support secure debug
  - Support secure OS
  - Except CPU, the other masters in the SoC can also support security and non-security mode by software-programmable
  - Some slave components in SoC can only be addressed by security master and the other slave components can be addressed by security master or non-security master by software-programmable
  - System SRAM (share memory), security programmable.
  - External DDR space can be divided into 16 parts, each part can be software-programmable to be enabled by each master
- Mailbox
  - One Mailbox in SoC to service CPU and MCU communication
  - Support four mailbox elements, each element includes one data word, one command word register and one flag bit that can represent one interrupt
  - Provide 32 lock registers for software to use to indicate whether mailbox is occupied

### 1.2.5 Video CODEC

- Video Decoder
  - Real-time video decoder of
    - ◆ MPEG-1, MPEG-2, MPEG-4
    - ◆ H.263, H.264/AVC, H.265/HEVC, MVC
    - ◆ VC-1
    - ◆ AVS, AVS+,AVS2
  - MMU Embedded
  - Supports frame timeout interrupt, frame finish interrupt and bit stream error interrupt
  - Error detection and concealment support for all video formats
  - Output data format YUV420 semi-planar, YUV400(monochrome), YUV422 is supported by H.264
  - H.264/AVC BP/MP/HP profile @ level 5.1; H.264/AVC MVC; up to 4Kx2K @ 60fps
  - H.265/HEVC Main/Main10 profile @ level 5.1 High-tier; up to 4Kx2K @ 60fps
  - AVS2 4KX2K @60fps
  - MPEG-1, Main profile, up to 1080P @ 60fps
  - MPEG-2, SP@ML, MP@HL, up to 1080P @ 60fps
  - MPEG-4, ASP profile @ level 5, up to 1080P @ 60fps
  - AVS, Jizhun profile @ level 6.0; up to 1080P @ 60fps
  - AVS-P16 (AVS+), up to 1080P @ 60fps
  - H.263, up to 576P @ 60fps
  - VC-1, SP@ML, MP@HL, AP@L0-3, up to 1080P @ 60fps
- Video Encoder
  - Support video encoder for H.264, HP@level4.2
  - H.264 maximum frame rate is up to 1920x1080 @60fps
  - Capable of encoding HEVC Main Profile @ L4.1 High-tier
  - H.265 resolution and frame rate are up to 1920x1080 @60fps
  - JPEG encoder included

### 1.2.6 JPEG Decoder

- JPEG decoder
  - Input JPEG file : YCbCr 4:0:0, 4:2:0, 4:2:2, 4:4:0, 4:1:1 and 4:4:4 sampling formats
  - Output raw image : YCbCr 4:0:0, 4:2:0, 4:2:2, 4:4:0, 4:1:1 and 4:4:4 semi-planar
  - Decoder size is from 48x48 to 8176x8176(66.8Mpixels)
  - Support JPEG ROI(region of image) decode
  - Maximum data rate is up to 76million pixels per second

### 1.2.7 Image Enhancement (VDPP module)

- Image format support
  - Input data: YUV420/YUV422
  - Output data: YUV420/YUV422/YUV444
  - YUV swap
  - UV SP/P
  - BT601\_l/BT601\_f/BT709\_l/BT709\_f color space conversion
  - YUV up/down sampling
- De-interlace
  - 3x5 Y motion detection matrix
  - Source width up to 1920
  - Configured high frequency de-interlace
  - I4O2 (Input 4 field, output 2 frame) /I4O1B/I4O1T/I2O1B/I2O1T mode
- Post-Processing
  - Support DMSR
  - Support ZME(polyphaser filter based zoom in/zoom out)

### 1.2.8 2D Graphics Engine

- 2D Graphics Engine:
  - Source formats:
    - ◆ ABGR8888, XBGR888, ARGB8888, XRGB888
    - ◆ RGB888, RGB565
    - ◆ RGBA5551, RGBA4444
    - ◆ YUV420 planar, YUV420 semi-planar
    - ◆ YUV422 planar, YUV422 semi-planar
    - ◆ YUV 10-bit for YUV420/422 semi-planar
    - ◆ BPP8, BPP4, BPP2, BPP1
  - Destination formats:
    - ◆ ABGR8888, XBGR888, ARGB8888, XRGB888
    - ◆ RGB888, RGB565
    - ◆ RGBA5551, RGBA4444
    - ◆ YUV420 planar, YUV420 semi-planar
    - ◆ YUV422 planar, YUV422 semi-planar
  - Pixel Format conversion, BT.601/BT.709
  - Max resolution: 8192x8192 source, 4096x4096 destination
  - BitBLT
    - ◆ Two source BitBLT:
    - ◆ A+B=B only BitBLT, A support rotate and scale when B fixed
    - ◆ A+B=C second source (B) has same attribute with (C) plus rotation function
  - Color fill with gradient fill, and pattern fill
  - High-performance stretch and shrink
  - Monochrome expansion for text rendering
  - New comprehensive per-pixel alpha (color/alpha channel separately)
  - Alpha blending modes including Java 2 Porter-Duff compositing blending rules, chroma key, pattern mask, fading
  - Dither operation
  - 0, 90, 180 and 270-degree rotation
  - x-mirror and y-mirror rotation operation

### 1.2.9 Video Output Processor

- Video ports
  - Video Port0, max output resolution: 4096x2304@60Hz
  - Video Port1, max output resolution: 720x576@60Hz
- Cluster
  - Max input and output resolution 4096x2304
  - Support AFBCD
  - Support RGB/YUV/YUYV format
  - Support scale up/down
  - Support rotation
- ESMART 0/1/2/3
  - Max input resolution 2048x2160 and output resolution 4096x2304
  - Support RGB/YUV/YUYV format
  - Support scale up/down
  - Support 4 regions
- Overlay
  - Support up to 4-layer overlay for port0 and 2-layer overlay for port1
  - Support RGB/YUV domain overlay
  - Support HDR
    - ◆ Support HDR10
    - ◆ Support SDR2HLG
    - ◆ Support HDR VIVID
    - ◆ Support HLG
- Write back
  - Format: XRGB8888/RGB888/RGB565/YUV420
  - Max resolution: 1920x1080

### 1.2.10 Display Interface

- HDMI
  - Compliant with HDMI 2.0b
  - Support YUV440 4k x 2k @ 60fps
  - Support for 4k x 2k and 3D video formats
  - Support for up to 18Gbps bandwidth
  - HPD input analog comparator
  - Compliance HDMI compliance Test specification 1.4 and 2.x
  - Support HDCP 1.4 and 2.2
- CVBS
  - BT656 decoder
    - ◆ Support for interlace output
  - TV interface
    - ◆ TV encoder 10bit out for DAC
    - ◆ Up sample to 27MHz/108MHz
  - Resolution
    - ◆ PAL/NTSC
  - VDAC
    - ◆ 10-bit 1-channel current-steering DAC
    - ◆ Up to 300MHz update rate
    - ◆ Support single-ended or differential output
    - ◆ Programmable current output range: 0~34.7mA
    - ◆ 58dBc SFDR @Iout = 18.7mA, fclk = 300MHz and fout = 2MHz;
    - ◆ 55dBc SFDR @Iout = 26.7mA, fclk = 300MHz and fout = 2MHz;
    - ◆ DNL<1LSB, 1NL<2LSB
    - ◆ Support cable detection
    - ◆ Support BIST logic
    - ◆ APB slave interface for internal register access
    - ◆ Build-in bandgap reference
    - ◆ 1.8V IO supply and 0.9V core supply

### 1.2.11 Audio Interface

- SAI(Serial Audio Interface):
  - SAI0/SAI2 with 2 channel
    - ◆ Up to 2 channels for TX and 2 channels RX path
    - ◆ Audio resolution from 16bits to 32bits
    - ◆ Sample rate up to 192KHz
    - ◆ Provides master and slave work mode, software configurable
    - ◆ Support 3 I2S formats (normal, left-justified, right-justified)
    - ◆ Support 4 PCM formats (early, late1, late2, late3)
    - ◆ SAI and PCM cannot be used at the same time
    - ◆ SAI0 connect to GPIO
    - ◆ SAI2 connect to Audio CODEC, RX path not supported
  - SAI1/SAI3 with 8 channel
    - ◆ Up to 8 channels TX and 8 channels RX path
    - ◆ Audio resolution from 16bits to 32bits
    - ◆ Sample rate up to 192KHz
    - ◆ Provides master and slave work mode, software configurable
    - ◆ Support 3 I2S formats (normal, left-justified, right-justified)
    - ◆ SAI1 connect to GPIO
    - ◆ SAI3 connect to HDMI, RX path not supported
- PDM
  - Up to 8 channels
  - Audio resolution from 16bits to 24bits
  - Sample rate up to 192KHz
  - Support PDM master receive mode

- SPDIF
  - SPDIF connect to HDMI and GPIO
- Audio CODEC
  - 24bit DAC
  - Support Line-out
  - Support Mono, Stereo channel performance
  - Integrated digital interpolation and decimation filter.
  - Sampling rate of 8kHz/12kHz/16kHz/24kHz/32kHz/44.1KHz/48KHz/96KHz

### 1.2.12 Connectivity

- SDIO interface
  - Compatible with SDIO 3.0 protocol
  - 4bits data bus widths
- TS interface
  - Supports 2 TS input channels.
  - Supports 4 TS Input Mode: sync/valid mode in the case of serial TS input; nosync/valid mode, sync/valid, sync/burst mode in the case of parallel TS input.
  - Supports 2 TS sources: demodulators and local memory.
  - Supports 2 Built-in PTIs (Programmable Transport Interface) to process TS simultaneously, and Each PTI supports:
    - ◆ 96 PID filters.
    - ◆ TS descrambling with 8 sets of Control Word under CSA2.0 standard
    - ◆ 32 PES/ES filters with PTS/DTS extraction and ES start code detection.
    - ◆ 16 PCR extraction channels
    - ◆ 96 Section filters with CRC check, and three interrupt mode: stop per unit, full-stop, recycle mode with version number check
    - ◆ PID done and error interrupts for each channel
    - ◆ PCR/DTS/PTS extraction interrupt for each channel
  - Supports 1 PVR (Personal Video Recording) output channel.
  - 1 built-in multi-channel DMA Controller.
  - Support MMU
- Smart Card
  - Support ISO-7816
  - Support card activation and deactivation
  - Support cold/warm reset
  - Support Answer to Reset(ATR) response reception
  - Support T0 for asynchronous half-duplex character transmission
  - Support T1 for asynchronous half-duplex block transmission
  - Support automatic operating voltage class selection
  - Support adjustable clock rate and bit (baud) rate
  - Support configurable automatic byte repetition
- SPI Controller
  - Support serial-master and serial-slave mode, software-configurable
  - DMA-based or interrupt-based operation
  - Embedded two 32x16bits FIFO for TX and RX operation respectively
  - Support 2 chip-selects output in serial-master mode
  - 2 on-chip SPI controller
- UART Controller
  - 8 on-chip UART controller
  - DMA-based or interrupt-based operation
  - UART0/1/2Embedded two 64Bytes FIFO for TX and RX operation respectively
  - Support 5bit,6bit,7bit,8bit serial data transmit or receive
  - Standard asynchronous communication bits such as start, stop and parity

- Support different input clock for UART operation to get up to 4Mbps or another special baud rate
- Support non-integer clock divides for baud clock generation
- Support auto flow control mode
- I2C controller
  - 8 on-chip I2C controller
  - Multi-master I2C operation
  - Support 7bits and 10bits address mode
  - Software programmable clock frequency and transfer rate up to 400Kbit/s in the fast mode
  - Serial 8bits oriented and bidirectional data transfers can be made at up to 100Kbit/s in the standard mode
- MAC 10/100/1000 Ethernet Controller
  - Support 10/100/1000 Mbps data transfer rates with the RGMII interfaces
  - Support 10/100 Mbps data transfer rates with the RMII interfaces
  - Support both full-duplex and half-duplex operation
  - Supports IEEE 802.1Q VLAN tag detection for reception frames
  - Support detection of LAN wake-up frames and AMD Magic Packet frames
  - Support checking IPv4 header checksum and TCP, UDP, or ICMP checksum encapsulated in IPv4 or IPv6 datagram
  - Support for TCP Segmentation Offload (TSO) and UDP Fragmentation Offload (UFO)
- MAC 10/100M Ethernet controller and MAC PHY
  - Support one Ethernet controllers
  - Support 10/100-Mbps data transfer rates with the RMII interfaces
  - Support both full-duplex and half-duplex operation
- USB 2.0 Host
  - Compatible with USB 2.0 specification
  - Support One USB 2.0 Host
  - Supports high-speed(480Mbps), full-speed(12Mbps) and low-speed(1.5Mbps) mode
  - Support Enhanced Host Controller Interface Specification (EHCI), Revision 1.0
  - Support Open Host Controller Interface Specification (OHCI), Revision 1.0a
- USB3.0
  - One Dual-Role-Device (DRD) USB Subsystem
  - Support USB3.0 (5Gbps ) stand, equal to USB3.1 Gen1, USB3.2 Gen1 or USB 5Gbps
  - Support USB2.0 (up to 480Mbps) stand
  - Compatible Specification
    - ◆ Universal Serial Bus 3.0 Specification, Revision 1.0
    - ◆ Universal Serial Bus Specification, Revision 2.0 (exclude USB30TG\_2)
    - ◆ eXtensible Host Controller Interface for Universal Serial Bus (xHCI), Revision 1.1
  - Support Control/Bulk (including stream)/Interrupt/Isochronous Transfer
  - Simultaneous IN and OUT transfer for USB3.0
  - Descriptor caching and data pre-fetching used to improve system performance in high-latency systems
  - LPM protocol in USB 2.0 and U0, U1, U2, and U3 states for USB3.0
  - USB3.0 Device Features
    - ◆ Up to 10 IN endpoints, including control endpoint 0
    - ◆ Up to 6 OUT endpoints, including control endpoint 0
    - ◆ Up to 16 endpoint transfer resources, each one for each endpoint
    - ◆ Flexible endpoint configuration for multiple applications/USB set-configuration modes
    - ◆ Hardware handles ERDY and burst
    - ◆ Stream-based bulk endpoints with controller automatically initiating data

- movement
  - ◆ Isochronous endpoints with isochronous data in data buffers
  - ◆ Flexible Descriptor with rich set of features to support buffer interrupt moderation, multiple transfers, isochronous, control, and scattered buffering support
- USB3.0 xHCI Host Features
  - ◆ Support up to 64 devices
  - ◆ Support 1 interrupter
  - ◆ Support 1 USB2.0 port and 1 Super-Speed port
  - ◆ Support standard or open-source xHCI and class driver
- USB3.0 Dual-Role Device (DRD) Features
  - ◆ Static Device Operation
  - ◆ Static Host Operation
  - ◆ USB3.0/USB2.0 OTG A device and B device basing on ID
  - ◆ Not Support USB3.0/USB2.0 OTG session request protocol (SRP), host negotiation protocol (HNP) and Role Swap Protocol (RSP)
- Miscellaneous Features
  - ◆ USB2.0 PHY support Battery Charge detection
  - ◆ USB3.0 PHY combos with PCIe
- Multi-PHY Interface
  - Support multi-PHYs with PCIe2.1/USB3.0
  - One USB3 Host controller
  - One PCIe2.1 controller
  - USB 3.0 xHCI Host Controller
    - ◆ Support 1 USB2.0 port and 1 Super-Speed port
    - ◆ Concurrent USB3.0/USB2.0 traffic, up to 8.48Gbps bandwidth
    - ◆ Support standard or open-source xHCI and class driver
    - ◆ Static USB3.0 Device
    - ◆ Static USB3.0 xHCI host
    - ◆ USB3.0/USB2.0 OTG A device and B device basing on ID
  - PCIe2.1 interface
    - ◆ Compatible with PCI Express Base Specification Revision 3.0
    - ◆ Support Root Complex(RC) mode
    - ◆ Support 2.5Gbps and 5.0Gbps serial data transmission rate per lane per direction
    - ◆ Support one lane

### 1.2.13 Others

- Multiple group of GPIO
  - All of GPIOs can be used to generate interrupt to CPU
  - Support level trigger and edge trigger interrupt
  - Support configurable polarity of level trigger interrupt
  - Support configurable rising edge, falling edge and both edge trigger interrupt
- HDMI 5V IO
  - 3.3V power supply, 5V voltage tolerance
  - 4 IOs for HDMI HPD/CEC/DDC connection
- Temperature Sensor(TS-ADC)
  - 10-bits ADC up to 50KS/s sampling rate
  - -40~125°C temperature range and 5°C temperature resolution
- Successive Approximation ADC (SARADC)
  - 10-bit resolution
  - Up to 1MS/s sampling rate

- 4 single-ended input channels
- Current consumption: 0.5mA @ 1MS/s
- OTP
  - Support 8192bits
  - Support Idle, Read, Program operation
  - Support boot function
  - Support Bist function
- Package Type
  - WBBGA401L (body:13.3mm x 13.5mm; ball size: 0.3mm; ball pitch: 0.65/0.6mm)

Notes :

① DDR3/DDR3L/DDR4/LPDDR3/LPDDR4/LPDDR4X are not used simultaneously

② Support 1x USB2 Host+1x USB2 Otg+ PCIe or 1x USB2 Host + 1x USB3.0

### 1.3 Block Diagram

The following figure shows the basic block diagram.

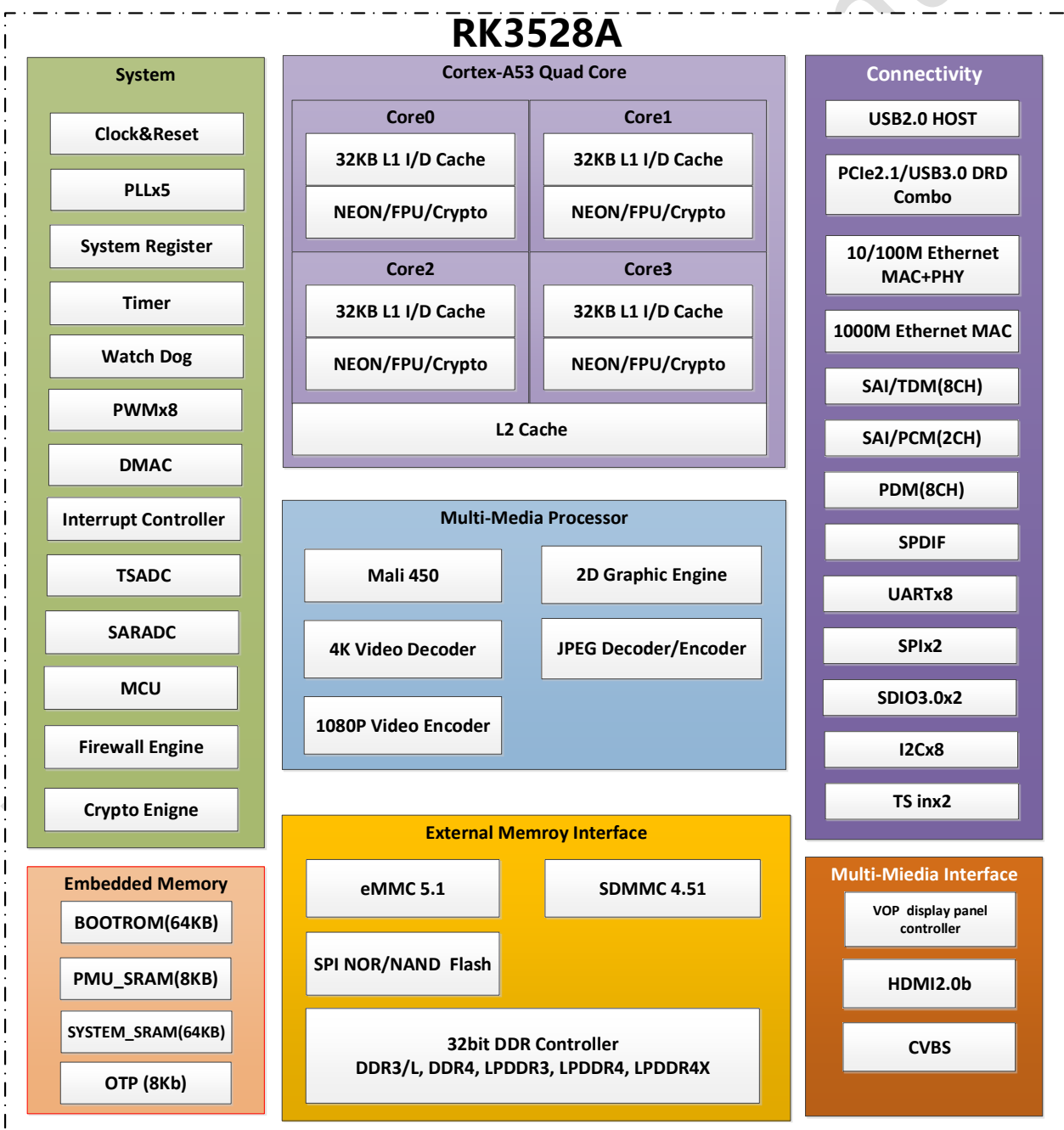

Fig.1-1 Block Diagram

## Chapter 2 Package Information

### 2.1 Order Information

Orderable Device	RoHS status	Package	Package Q'ty	Device Feature
RK3528A	RoHS	WBBGA401L	1190pcs	Quad-core Application Processor
RK3528A-D	RoHS	WBBGA401L	1190pcs	Quad-core Application Processor with the Dolby Audio function

### 2.2 Top Marking

- RK3528A

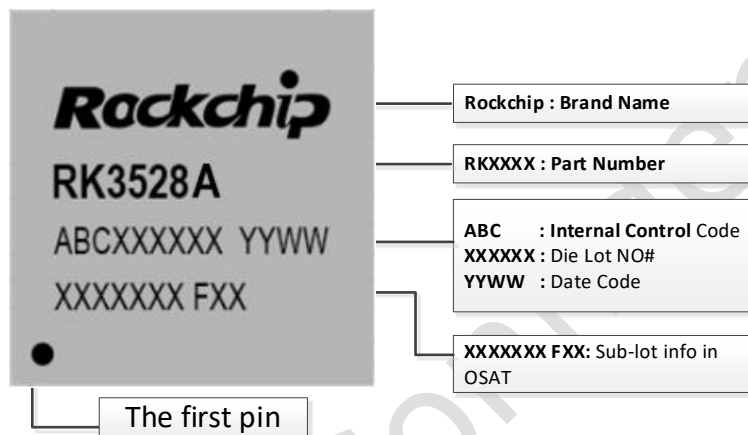

Fig.2-1 RK3528A Package definition

- RK3528A-D

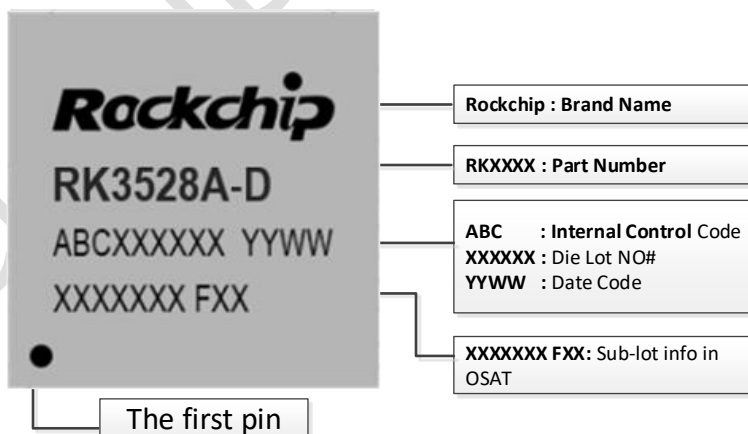

Fig.2-2 RK3528A-D Package definition

### 2.3 Package Dimension

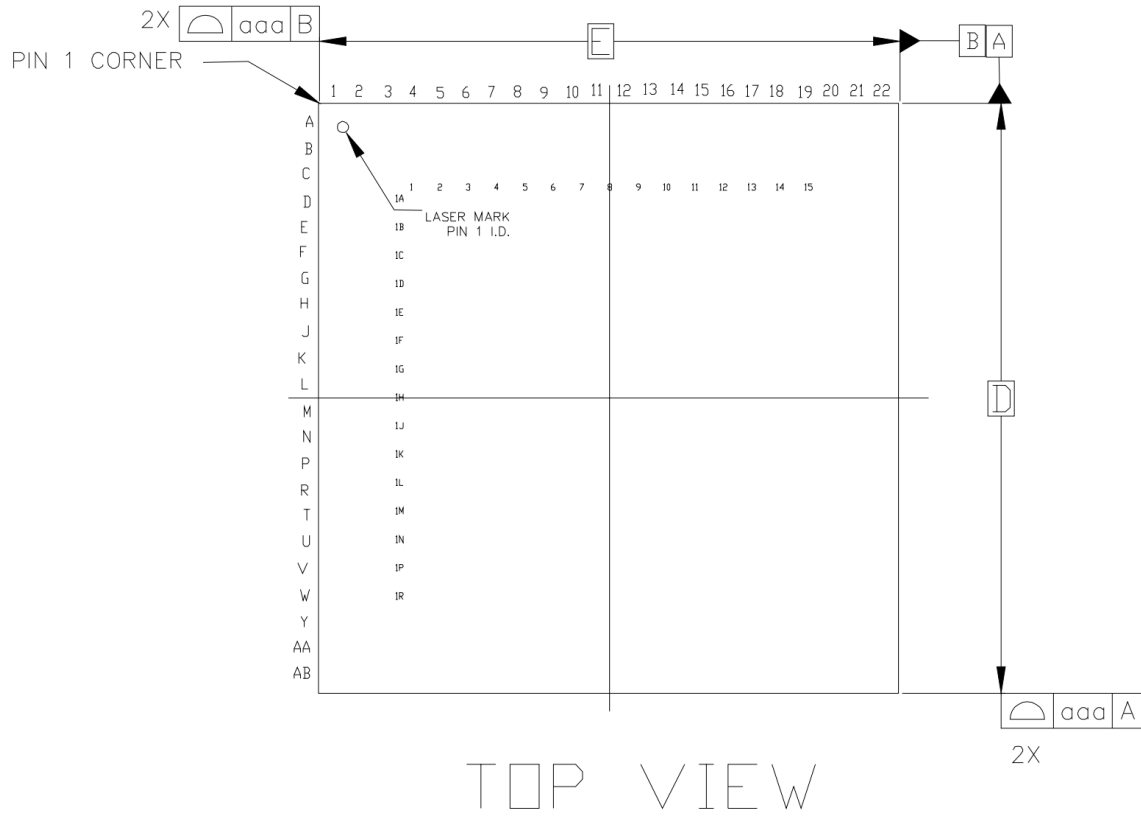
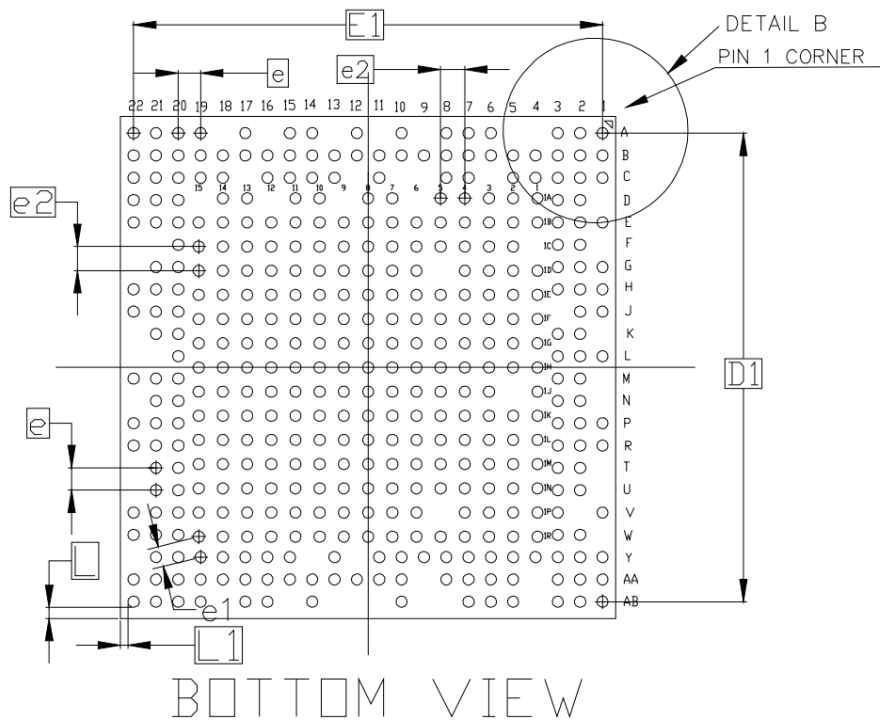
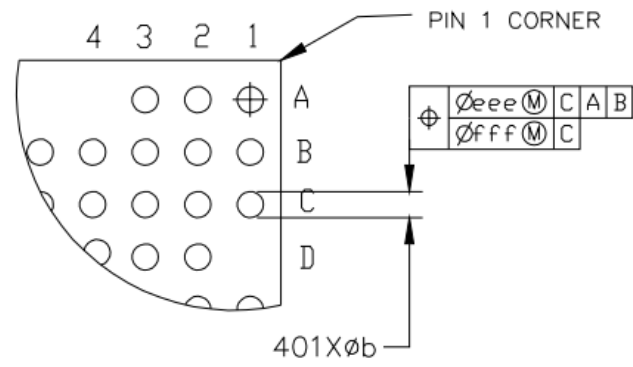

Fig.2-3 Package Top View





DETAIL B(2:1)

Fig.2-4 Package Bottom View

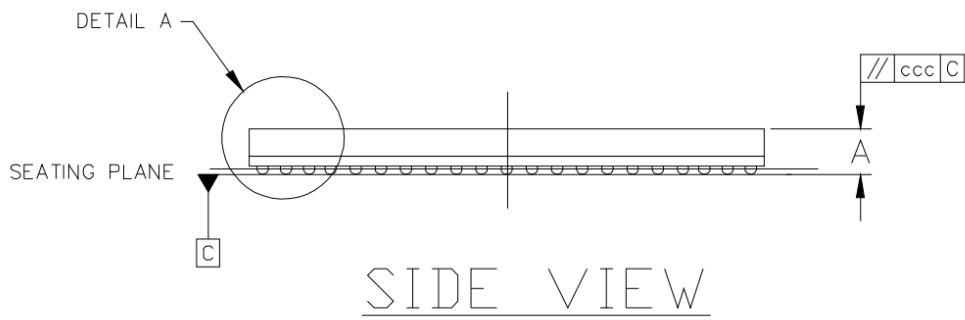

SIDE VIEW

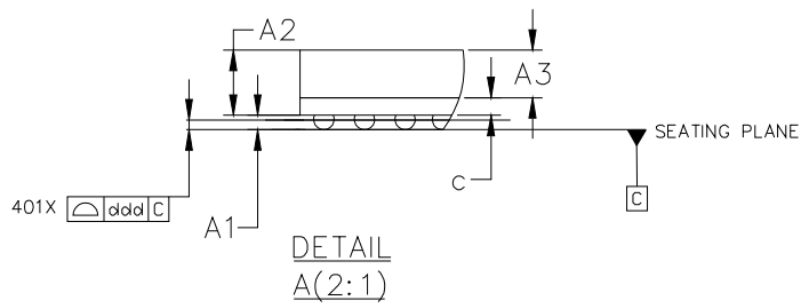

DETAIL A(2:1)

Fig.2-5 Package Side View

SYMBOL	MILLIMETER		
	MIN	NOM	MAX
A	1.09	1.17	1.25
A1	0.16	0.21	0.26
A2	0.91	0.96	1.01
A3	0.70 BASIC		
c	0.22	0.26	0.30
D	13.40	13.50	13.60
D1	12.60 BASIC		
E	13.20	13.30	13.40
E1	12.6 BASIC		
e	0.60 BASIC		
e1	0.55 BASIC		
e2	0.65 BASIC		
b	0.25	0.30	0.35
L	0.30 REF		
L1	0.20 REF		
aaa	0.15		
ccc	0.15		
ddd	0.10		
eee	0.15		
fff	0.08		

Fig.2-6 Package Dimension

## 2.4 MSL Information

Moisture sensitivity level: MSL3

## 2.5 Lead Finish/Ball Material Information

Lead finish/Ball material: SnAgCu

## 2.6 Pin Number List

Table 2-1 Pin Number Order Information

Pin name	Pin#	Pin name	Pin#
VSS0	A1	VSS38	1B7
DDRRPHY_A_DQS1N/DDR4_DQSU_N_A/LPDDR4_DQS1N_A/DDR3_DQS1N/LPDDR3_DQS2N	A2	VSS39	1B8
VSS1	A3	DDRRPHY_A_DQ5/DDR4_DQL5_A/LPDDR4_DQ5_A/DDR3_D7/LPDDR3_D5	1B9
DDRRPHY_A_DQS0P/DDR4_DQSL_P_A/LPDDR4_DQS0P_A/DDR3_DQS0P/LPDDR3_DQS0P	A6	DDRRPHY_B_DQ7/DDR4_DQU2_B/LPDDR4_DQ7_B/DDR3_D25/LPDDR3_D11	1B10
VSS2	A7	DDRRPHY_B_DQ5/DDR4_DQU3_B/LPDDR4_DQ5_B/DDR3_D24/LPDDR3_D15	1B11
DDRRPHY_A_DQ3/DDR4_DQL1_A/LPDDR4_DQ3_A/DDR3_D1/LPDDR3_D3	A8	VSS40	1B12
DDRRPHY_B_DQ3/DDR4_DQU5_B/LPDDR4_DQ3_B/DDR3_D30/LPDDR3_D8	A10	VSS41	1B13
DDRRPHY_B_DQS0N/DDR4_DQSU_N_B/LPDDR4_DQS0N_B/DDR3_DQS3N/LPDDR3_DQS1N	A12	VCCIO2	1B14
DDRRPHY_B_DQ0/DDR4_DQU4_B/LPDDR4_DQ0_B/DDR3_D29/LPDDR3_D14	A14	VSS42	1B15

Pin name	Pin#	Pin name	Pin#
DDRPHY_B_DM0/DDR4_DMU_B/LPDDR4_DM0_B/DDR3_DM3/LPDDR3_DM1	A15	DDRPHY_A7/DDR4_A7/LPDDR4_A4_A/DDR3_A6	1C2
DDRPHY_B_DQS1N/DDR4_DQSL_N_B/LPDDR4_DQS1N_B/DDR3_DQS2N/LPDDR3_DQS3N	A17	DDR_RZQ	1C3
VSS3	A19	DDR_PLL_AVSS	1C4
DDRPHY_B_DQ11/DDR4_DQL6_B/LPDDR4_DQ11_B/DDR3_D22/LPDDR3_D31	A20	VSS43	1C5
SDMMC_D2/JTAG_CPU_TCK_M0/UART4_RX/HSM_CLK_OUT_M0/GPIO2_A2_u	A21	DDR_VDDQ_3	1C6
VSS4	A22	DDR_VDDQ_4	1C7
PWM3_M0/UART1_RX_M1/I2C1_SDA_M1/GPIO4_C6_d	AA1	DDR_VDDQ_5	1C8
SDIO0_DET_N/UART5_CTSN_M0/I2C2_SDA_M1/GPIO1_A6_d	AA2	VSS44	1C9
SDIO0_CLK/UART5_RTSN_M0/I2C2_SCL_M1/GPIO1_A5_d	AA3	VSS45	1C10
VSS27	AA5	VSS46	1C11
EMMC_CMD/UART5_RX_M1/I2C6_SCL_M1/GPIO1_D4_u	AA6	VSS47	1C12
EMMC_D4/FSPI_CSN0/GPIO1_D0_u	AA7	VSS48	1C13
EMMC_D1/FSPI_D1/GPIO1_C5_u	AA8	VSS49	1C14
SARADC_IN0	AA10	VSS50	1C15
USB30_OTG0_SSRXP/PCIE20_RXDP	AA11	VSS51	1D1
AVSS2_VSS1	AA12	VSS52	1D2
USB30_OTG0_SSTXN/PCIE20_TXDN	AA13	VSS53	1D3
PCIE20_REFCLKP	AA14	DDR_VDDQ_2	1D4
PWM6_M2/RGMII1_TXER/UART6_TX_M1/I2C3_SCL_M1/GPIO3_C1_d	AA15	DDR_VDDQL_2	1D6
I2S0_SDI_M0/RGMII1_MDIO/TSIO_D3/GPIO3_B7_d	AA16	DDR_VDDQL_3	1D7
I2S0_LRCK_M0/RGMII1_MDC/TSIO_D2/GPIO3_B6_d	AA17	DDR_VDDQL_4	1D8
UART2_CTSN_M0/RGMII1_RXD0/TSIO_D4/GPIO3_A3_d	AA18	VSS54	1D9
UART2_RX_M0/RGMII1_TXD1/TSIO_D7/GPIO3_A0_d	AA19	PMUPLL_AVSS1	1D10
SDIO1_D1/RGMII1_RXD2/TSI1_SYNC/UART6_RX_M0/PCI_E_WAKEN_M0/GPIO3_A7_d	AA20	USB20_DVDD0V9	1D11
SDIO1_D3/RGMII1_TXD2/TSIO_D0/UART7_RTSN_M0/GPIO3_B1_d	AA21	USB20_AVDD1V8	1D12
SDIO1_CLK/RGMII1_TXCLK/TSI1_D0/UART6_CTSN/GPIO3_A4_d	AA22	USB20_AVDD3V3	1D13
VSS28	AB1	USB20_OTG0_VBUSDET	1D14
SDIO0_D0/I2C3_SCL_M0/SCR_DET_N_M0/PCIE_CLKREQN_M1/GPIO1_A0_d	AB2	AVSS1_VSS4	1D15
SDIO0_CMD/PWM4_M1/HSM_CLK_OUT_M1/GPIO1_A4_d	AB3	DDRPHY_A0/DDR4_A0/LPDDR4_ODT1_B/DDR3_A9/LPDDR3_ODT2	1E1
EMMC_CLK/FSPI_CLK/GPIO1_D5_d	AB5	DDRPHY_ODT0/DDR4_ODT0/LPDDR4_ODT1_A/DDR3_WEN/LPDDR3_ODT0	1E2
EMMC_STRB/UART5_TX_M1/I2C6_SDA_M1/GPIO1_D7_d	AB6	VSS55	1E3
EMMC_D3/FSPI_D3/GPIO1_C7_u	AB7	DDR_VDDQ_1	1E4
SARADC_IN1	AB10	DDR_VDDQL_1	1E5
PCIE20_REFCLKN	AB14	VSS56	1E6
I2S0_SDO_M0/RGMII1_TXEN/TSIO_FAIL/GPIO3_C0_d	AB16	VSS57	1E7
I2S0_SCLK_M0/ETH_CLK_25M_OUT/TSIO_D1/GPIO3_B5_d	AB17	VSS58	1E8
RGMII1_RXDV_CRS/GPIO3_C2_d	AB19	VSS59	1E9
PWM5_M1/SPDIF_TX_M2/CLK_32K_OUT_M0/UART6_RX_M1/I2C3_SDA_M1/REF_CLK_OUT_M1/GPIO3_C3_d	AB20	FEPHY_REXT	1E10
SDIO1_D0/RGMII1_RXD3/TSI1_VALID/UART6_TX_M0/PCI_E_CLKREQN_M0/GPIO3_A6_d	AB21	FEPHY_AVDD0V9	1E11
VSS29	AB22	FEPHY_AVDD1V8	1E12

Pin name	Pin#	Pin name	Pin#
DDRRPHY_A_DM1/DDR4_DMU_A/LPDDR4_DM1_A/DDR3_DM1/LPDDR3_DM2	B1	OTP_VCC1V8	1E13
DDRRPHY_A_DQS1P/DDR4_DQSU_P_A/LPDDR4_DQS1P_A/DDR3_DQS1P/LPDDR3_DQS2P	B2	FEPHY_AVDD3V3	1E14
DDRRPHY_A_DQ13/DDR4_DQU3_A/LPDDR4_DQ13_A/DDR3_D8/LPDDR3_D23	B3	AVSS1_VSS5	1E15
VSS5	B4	DDRRPHY_A2/DDR4_A2/LPDDR4_ODT0_B/DDR3_A13/LPDDR3_ODT3	1F1
DDRRPHY_A_DQ1/DDR4_DQL2_A/LPDDR4_DQ1_A/DDR3_D0/LPDDR3_D1	B5	VSS60	1F2
DDRRPHY_A_DQS0N/DDR4_DQSL_N_A/LPDDR4_DQS0N_A/DDR3_DQS0N/LPDDR3_DQS0N	B6	VSS61	1F3
VSS6	B7	DDR_VDDQ_0	1F4
DDRRPHY_A_DQ2/DDR4_DQL0_A/LPDDR4_DQ2_A/DDR3_D2/LPDDR3_D2	B8	DDR_VDDQL_0	1F5
DDRRPHY_A_DQ4/DDR4_DQL4_A/LPDDR4_DQ4_A/DDR3_D6/LPDDR3_D4	B9	VSS62	1F6
DDRRPHY_B_DQ4/DDR4_DQU7_B/LPDDR4_DQ4_B/DDR3_D26/LPDDR3_D9	B10	VSS63	1F7
DDRRPHY_B_DQ2/DDR4_DQU1_B/LPDDR4_DQ2_B/DDR3_D28/LPDDR3_D13	B11	VSS64	1F8
DDRRPHY_B_DQS0P/DDR4_DQSU_P_B/LPDDR4_DQS0P_B/DDR3_DQS3P/LPDDR3_DQS1P	B12	VSS65	1F9
DDRRPHY_B_DQ1/DDR4_DQU0_B/LPDDR4_DQ1_B/DDR3_D31/LPDDR3_D12	B13	VSS66	1F10
VSS7	B14	AVSS1_VSS6	1F11
DDRRPHY_B_DQ6/DDR4_DQU6_B/LPDDR4_DQ6_B/DDR3_D27/LPDDR3_D10	B15	AVSS1_VSS7	1F12
DDRRPHY_B_DQ13/DDR4_DQL2_B/LPDDR4_DQ13_B/DDR3_D20/LPDDR3_D24	B16	AVSS1_VSS8	1F13
DDRRPHY_B_DQS1P/DDR4_DQSL_P_B/LPDDR4_DQS1P_B/DDR3_DQS2P/LPDDR3_DQS3P	B17	AVSS1_VSS9	1F14
DDRRPHY_B_DQ8/DDR4_DQL1_B/LPDDR4_DQ8_B/DDR3_D17/LPDDR3_D27	B18	AVSS1_VSS10	1F15
DDRRPHY_B_DQ12/DDR4_DQL0_B/LPDDR4_DQ12_B/DDR3_D16/LPDDR3_D28	B19	DDRRPHY_BA0/DDR4_BA0/LPDDR4_CKE0_B/DDR3_BA2/LPDDR3_CKE0	1G1
DDRRPHY_B_DQ10/DDR4_DQL4_B/LPDDR4_DQ10_B/DDR3_D18/LPDDR3_D30	B20	DDRRPHY_A6/DDR4_A6/LPDDR4_CSN1_B/DDR3_A3/LPDDR3_CSN2	1G2
SDMMC_D3/JTAG_CPU_TMS_M0/UART4_TX/SCR_DATA_M1/GPIO2_A3_u	B21	VSS67	1G3
SDMMC_CLK/JTAG_MCU_TMS_M0/SCR_CLK_M1/I2C7_SCL/FEPHY_LED_SPD_M1/TEST_CLK_OUT/GPIO2_A5_d	B22	VSS68	1G4
DDRRPHY_A_DQ8/DDR4_DQU1_A/LPDDR4_DQ8_A/DDR3_D12/LPDDR3_D19	C1	VSS69	1G5
DDRRPHY_A_DQ9/DDR4_DQU5_A/LPDDR4_DQ9_A/DDR3_D14/LPDDR3_D16	C2	VSS70	1G6
DDRRPHY_A_DM0/DDR4_DML_A/LPDDR4_DM0_A/DDR3_DM0/LPDDR3_DM0	C3	VSS71	1G7
DDRRPHY_A_DQ0/DDR4_DQL6_A/LPDDR4_DQ0_A/DDR3_D4/LPDDR3_D0	C4	VSS72	1G8
DDRRPHY_A5/DDR4_A5/LPDDR4_A1_A/DDR3_A4	C5	VSS73	1G9
VSS8	C7	VSS74	1G10
DDRRPHY_A_DQ10/DDR4_DQU0_A/LPDDR4_DQ10_A/DDR3_D15/LPDDR3_D21	C8	HDMI_REXT	1G11
DDRRPHY_A_DQ15/DDR4_DQU6_A/LPDDR4_DQ15_A/DDR3_D11/LPDDR3_D18	C11	HDMI_TX_DVDD0V9	1G12
DDRRPHY_A_DQ6/DDR4_DQL7_A/LPDDR4_DQ6_A/DDR3_D5/LPDDR3_D6	C13	HDMI_TX_AVDD1V8	1G13
VSS9	C14	AVSS1_VSS11	1G14
VSS10	C15	AVSS1_VSS12	1G15
DDRRPHY_B_DQ15/DDR4_DQL5_B/LPDDR4_DQ15_B/DDR3_D23/LPDDR3_D29	C16	DDRRPHY_A14/DDR4_WEN/A14/LPDDR4_CSN0_B/DDR3_ODT0/LPDDR3_CSN3	1H1
DDRRPHY_B_DM1/DDR4_DML_B/LPDDR4_DM1_B/DDR3_DM2/LPDDR3_DM3	C18	DDRRPHY_CKE/DDR4_CKE/LPDDR4_CKE1_B/DDR3_RASN	1H2
VSS11	C19	VSS75	1H3
SDMMC_CMD/JTAG_MCU_TCK_M0/PWM3_M1/SCR_RSTN_M1/FEPHY_LED_DPX_M1/GPIO2_A4_u	C20	DDR_VREFOUT	1H4

Pin name	Pin#	Pin name	Pin#
SDMMC_D0/UART0_RX_M1/UART4_RTSN/I2C4_SCL/GPIO2_A0_u	C21	GPU_DVDD_0	1H5
SDMMC_D1/UART0_TX_M1/UART4_CTSN/I2C4_SDA/GPIO2_A1_u	C22	VSS76	1H6
DDRPHY_A_DQ12/DDR4_DQU7_A/LPDDR4_DQ12_A/DDR3_D10/LPDDR3_D20	D2	VSS77	1H7
VSS12	D3	LOGIC_DVDD_0	1H8
USB20_OTG0_ID	D20	LOGIC_DVDD_1	1H9
SDMMC_DET/SCR_DET_M1/I2C7_SDA/FEPHY_LED_LIN_K_M1/GPIO2_A6_u	D21	VSS78	1H10
VSS13	D22	TVSS	1H11
DDRPHY_A12/DDR4_A12/LPDDR4_A2_A/DDR3_A10/LPDDR3_A4	E1	PMU_LOGIC_DVDD	1H12
DDRPHY_A15/DDR4_CASN/A15/LPDDR4_A3_A/DDR3_BA1/LPDDR3_A0	E2	PMU_PLL_AVDD0V9	1H13
VSS14	E3	PMU_PLL_AVDD1V8	1H14
USB20_HOST1_DP	E20	VSS79	1H15
USB20_OTG0_DP	E21	VSS80	1J1
USB20_OTG0_DM	E22	VCCIO4	1J3
DDRPHY_BA1/DDR4_BA1/LPDDR4_A5_A/DDR3_A12/LPDDR3_A1	F2	VSS81	1J4
DDRPHY_CSN0/DDR4_CSN0/LPDDR4_CSN1_A/DDR3_CASN/LPDDR3_CSN1	F3	GPU_DVDD_1	1J5
USB20_HOST1_DM	F20	GPU_DVDD_2	1J6
DDRPHY_A9/DDR4_A9/LPDDR4_CLKP_A/DDR3_A11/LPDDR3_A2	G1	VSS82	1J7
DDRPHY_A13/DDR4_A13/LPDDR4_CLKN_A/DDR3_A8/LPDDR3_A3	G2	VSS83	1J8
VSS15	G3	LOGIC_DVDD_2	1J9
FEPHY_TXP	G20	LOGIC_DVDD_3	1J10
FEPHY_TXN	G21	PMUPLL_AVSS2	1J11
DDRPHY_CLKP/DDR4_CLKP/LPDDR4_CLKP_B/DDR3_CLKP/LPDDR3_CLKP	H1	NPOR	1J12
DDRPHY_CLKN/DDR4_CLKN/LPDDR4_CLKN_B/DDR3_CLKN/LPDDR3_CLKN	H2	PMUIO_VCC3V3	1J13
VSS16	H3	REF_CLK_OUT_M0/GPIO0_A1_d	1J14
AVSS1_VSS0	H20	VSS84	1J15
FEPHY_RXP	H21	VSS85	1K1
FEPHY_RXN	H22	DDR_PLL_AVDD1V8	1K2
VSS17	J1	VSS86	1K3
DDRPHY_A1/DDR4_A1/LPDDR4_CKE1_A/DDR3_A14	J2	VSS87	1K4
AVSS1_VSS1	J20	VSS88	1K5
HDMI_TX_D2N	J21	VSS89	1K6
HDMI_TX_D2P	J22	VSS90	1K7
VSS18	K2	VSS91	1K8
DDRPHY_A3/DDR4_A3/LPDDR4_CKE0_A/DDR3_A1	K3	LOGIC_DVDD_4	1K9
HDMI_TX_D1N	K20	VSS92	1K10
HDMI_TX_D1P	K21	VDAC_AVSS	1K11
DDRPHY_A4/DDR4_A4/LPDDR4_A0_B/DDR3_A2/LPDDR3_A5	L1	VDAC_IREF	1K12
VSS19	L2	VDAC_AVDD1V8	1K13
DDRPHY_A10/DDR4_A10/LPDDR4_A1_B/DDR3_A0	L3	ACODEC_AVDD1V8	1K14
HDMI_TX_D0P	L20	VSS93	1K15
DDRPHY_A8/DDR4_A8/LPDDR4_A4_B/DDR3_A5/LPDDR3_A6	M2	PWR_CTRL1/SPI0_CSN0/GPIO4_B6_u	1L1
DDRPHY_A11/DDR4_A11/LPDDR4_A5_B/DDR3_A7/LPDDR3_A7	M3	VSS94	1L2
HDMI_TX_D0N	M20	VSS95	1L3

Pin name	Pin#	Pin name	Pin#
AVSS1_VSS2	M21	CPU_DVDD_0	1L4
AVSS1_VSS3	M22	CPU_DVDD_1	1L5
DDRRPHY_BG0/DDR4_BG0/LPDDR4_A3_B/DDR3_BA0/LPD DR3_A8	N2	VSS96	1L6
DDRRPHY_ACTN/DDR4_ACTN/LPDDR4_A2_B/DDR3_CSN0/ LPDDR3_A9	N3	VSS97	1L7
HDMI_TX_CLKP	N20	VSS98	1L8
HDMI_TX_CLKN	N21	LOGIC_DVDD_5	1L9
DDRRPHY_RESETN/DDR4_RESETN/LPDDR4_RESETN/DDR3 _RESETN	P1	VSS99	1L10
VSS20	P2	VSS100	1L11
PWM7_M0/PWR_CTRL0/GPIO4_C2_d	P3	ACODEC_AVSS	1L12
HDMI_TX_SDA_5V0_od	P20	VSS101	1L13
HDMI_TX_CEC_3V3_u	P21	VSS102	1L14
HDMI_TX_SCL_5V0_od	P22	VSS103	1L15
SDMMC0_PWREN/I2C0_SCL_M1/GPIO4_A1_d	R1	I2S1_LRCK/UART1_TX_M0/GPIO4_A6_d	1M1
I2S1_SDI0/SPI0_CLK/GPIO4_B4_d	R2	I2S1_MCLK/UART1_CTSN/PDM_CLK1/GPIO4 _A4_d	1M2
SPDIF_TX_M0/I2C0_SDA_M1/PMU_DEBUG/GPIO4_A0_d	R3	CPU_DVDD_2	1M3
VSS21	R20	CPU_DVDD_3	1M4
GPI00_A0_d	R21	CPU_DVDD_4	1M5
HDMI_TX_HPD_5V0_d	R22	VSS104	1M6
UART0_TX_M0/JTAG_CPU_TCK_M1/JTAG_MCU_TCK_M1/G PIO4_D0_d	T2	VSS105	1M7
UART0_RX_M0/JTAG_CPU_TMS_M1/JTAG_MCU_TMS_M1/ GPIO4_C7_u	T3	I2S0_SDO_M1/SPI1_MISO/GPIO1_C0_d	1M8
OSC_SOC_XOUT	T20	VSS106	1M9
OSC_SOC_XIN	T21	VSS107	1M10
I2S1_SDI3/I2C1_SDA_M0/UART3_RTSN/GPIO4_A2_d	U2	VSS108	1M11
I2S1_SDI2/I2C1_SCL_M0/UART3_CTSN/GPIO4_A3_d	U3	ACODEC_VCM	1M12
VDAC_IOUTP	U20	VCCIO3	1M13
VSS22	U21	VSS109	1M14
PWM1_M0/I2C0_SCL_M0/ARM_AVS/GPIO4_C4_d	V1	VSS110	1M15
PWM4_M0/FEPHY_LED_SPD_M0/UART3_RX_M1/GPIO4_B 7_d	V3	PWM0_M0/I2C0_SDA_M0/GPU_AVS/GPIO4_ C3_d	1N1
VSS23	V20	I2S1_SDO2/UART3_TX_M0/PDM_SDI1/GPIO 4_B1_d	1N2
VSS24	V21	I2S1_SDO3/SPI0_MOSI/PDM_SDI0/GPIO4_B 2_d	1N3
ACODEC_LINEOUT_L	V22	SPI1_CSN1/PWM7_M1/GPIO1_C2_d	1N4
PWM6_M0/SPI0_CSN1/PDM_SDI3/GPIO4_C1_d	W2	I2S0_MCLK_M1/GPIO1_B4_d	1N5
I2S1_SDI1/SPI0_MISO/PDM_SDI2/GPIO4_B3_d	W3	VCCIO0	1N6
VSS25	W20	SPI1_CSN0/GPIO1_C1_u	1N7
VSS26	W21	I2S0_LRCK_M1/SPI1_CLK/GPIO1_B6_d	1N8
ACODEC_LINEOUT_R	W22	AVSS2_VSS2	1N9
FEPHY_LED_DPX_M0/PDM_CLK0/GPIO4_B5_d	Y1	AVSS2_VSS3	1N10
PWM5_M0/FEPHY_LED_LINK_M0/UART3_TX_M1/GPIO4_C 0_d	Y2	SARADC_AVDD1V8	1N11
SDIO0_D1/I2C3_SDA_M0/SCR_DATA_M0/PCIE_WAKEN_ M1/GPIO1_A1_d	Y3	VSS111	1N12
SDIO0_D2/UART5_RX_M0/SCR_CLK_M0/PCIE_PERSTN_M 1/PWM0_M1/GPIO1_A2_d	Y4	VSS112	1N13
CLK_32K_OUT_M1/SPDIF_TX_M1/PWM6_M1/GPIO1_C3_d	Y5	VSS113	1N14
EMMC_D5/FSPI_CSN1/GPIO1_D1_u	Y6	VDAC_IOUTN	1N15

Pin name	Pin#	Pin name	Pin#
EMMC_D0/FSPI_D0/GPIO1_C4_u	Y7	PWM2_M0/UART1_TX_M1/I2C1_SCL_M1/GPIO4_C5_d	1P1
EMMC_D2/FSPI_D2/GPIO1_C6_u	Y8	I2S1_SCLK/UART1_RTSN/GPIO4_A5_d	1P2
EMMC_D6/UART5_RTSN_M1/I2C5_SCL_M1/GPIO1_D2_u	Y9	I2S1_SDO0/UART1_RX_M0/GPIO4_A7_d	1P3
I2S0_SDI_M1/SPI1_MOSI/GPIO1_B7_d	Y10	UART2_RTSN_M1/I2C5_SCL_M0/UART7_TX_M1/GPIO1_B2_d	1P4
USB30_OTG0_SSRXN/PCIE20_RXDN	Y11	UART2_CTSN_M1/I2C5_SDA_M0/UART7_RX_M1/GPIO1_B3_d	1P6
USB30_OTG0_SSTXP/PCIE20_TXDP	Y13	UART2_RX_M1/UART7_CTSN_M1/GPIO1_B0_d	1P7
AVSS2_VSS0	Y15	VCCIO1	1P8
I2S0_MCLK_M0/RGMII1_CLK/TSIO_SYNC/GPIO3_B4_d	Y16	SARADC_IN3	1P9
UART2_RTSN_M0/RGMII1_RXD1/TSIO_D5/GPIO3_A2_d	Y17	AVSS2_VSS4	1P10
UART2_TX_M0/RGMII1_TXD0/TSIO_D6/GPIO3_A1_d	Y18	PCIE20_USB30_AVDD0V9	1P11
SDIO1_D2/RGMII1_TXD3/UART7_CTSN_M0/PCIE_PERSTN_M0/GPIO3_B0_d	Y19	PCIE20_USB30_AVDD1V8	1P12
SDIO1_CMD/RGMII1_RXCLK/TSI1_CLKIN/UART6_RTSN/GPIO3_A5_d	Y20	VSS114	1P13
SDIO1_DET/TSIO_VALID/UART7_RX_M0/I2C6_SDA_M0/GPIO3_B3_d	Y21	VSS115	1P14
VSS30	1A1	VSS116	1P15
DDRRPHY_CSN1/DDR4_CSN1/LPDDR4_CSN0_A/DDR3_CSN1/LPDDR3_CSN0	1A2	SDIO0_D3/UART5_TX_M0/SCR_RSTN_M0/PWM1_M1/GPIO1_A3_d	1R1
DDRRPHY_A16/DDR4_RASN/A16/LPDDR4_A0_A/DDR3_CKE0	1A3	I2S1_SDO1/UART3_RX_M0/GPIO4_B0_d	1R2
VSS31	1A4	VSS117	1R3
DDRRPHY_A_DQ11/DDR4_DQU2_A/LPDDR4_DQ11_A/DDR3_D9/LPDDR3_D17	1A5	VSS118	1R4
DDRRPHY_A_DQ14/DDR4_DQU4_A/LPDDR4_DQ14_A/DDR3_D13/LPDDR3_D22	1A7	EMMC_D7/UART5_CTSN_M1/I2C5_SDA_M1/GPIO1_D3_u	1R5
DDRRPHY_A_DQ7/DDR4_DQL3_A/LPDDR4_DQ7_A/DDR3_D3/LPDDR3_D7	1A8	UART2_TX_M1/UART7_RTSN_M1/GPIO1_B1_d	1R6
VSS32	1A10	SDIO0_PWREN/PWM2_M1/GPIO1_A7_d	1R7
DDRRPHY_B_DQ14/DDR4_DQL7_B/LPDDR4_DQ14_B/DDR3_D21/LPDDR3_D25	1A11	I2S0_SCLK_M1/GPIO1_B5_d	1R8
DDRRPHY_B_DQ9/DDR4_DQL3_B/LPDDR4_DQ9_B/DDR3_D19/LPDDR3_D26	1A13	SARADC_IN2	1R9
VSS33	1A14	AVSS2_VSS5	1R10
VSS34	1B1	AVSS2_VSS6	1R11
DDRRPHY_ODT1/DDR4_ODT1/LPDDR4_ODT0_A/DDR3_ODT1/LPDDR3_ODT1	1B2	AVSS2_VSS7	1R12
DDRRPHY_BG1/DDR4_BG1/DDR3_A15	1B3	VSS119	1R13
VSS35	1B4	VSS120	1R14
VSS36	1B5	SDIO1_PWREN/TSIO_CLKIN/UART7_TX_M0/I2C6_SCL_M0/GPIO3_B2_d	1R15
VSS37	1B6		

## Chapter 3 Electrical Specification

### 3.1 Absolute Ratings

The below table provides the absolute ratings.

Absolute maximum or minimum ratings specify the values beyond which the device may be damaged permanently. Long-term exposure to absolute maximum ratings conditions may affect device reliability.

Table 3-1 Absolute ratings

Parameters	Related Power Group	Min	Max	Unit
Supply voltage for CPU	CPU_DVDD	-0.3	TBD	V
Supply voltage for GPU	GPU_DVDD	-0.3	TBD	V
Supply voltage for Logic	LOGIC_DVDD	-0.3	TBD	V
Supply voltage for PMU	PMU_LOGIC_DVDD	-0.3	TBD	V
0.9V supply voltage	PMU_PLL_AVDD0V9 HDMI_TX_DVDD0V9 USB20_DVDD0V9 FEPHY_AVDD0V9 PCIE20_USB30_AVDD0V9	-0.3	TBD	V
1.8V/3.3V supply voltage	VCCIOi(i=0~4, 1.8V/3.3V mode)	-0.3	TBD	V
1.8V supply voltage	PMU_PLL_AVDD1V8 HDMI_TX_AVDD1V8 OTP_VCC1V8 USB20_AVDD1V8 FEPHY_AVDD1V8 VDAC_AVDD1V8 ACODEC_AVDD1V8 PCIE20_USB30_AVDDD1V8 SARADC_AVDD1V8 DDR_PLL_AVDD1V8	-0.3	TBD	V
3.3V supply voltage	PMUIO_VCC3V3 USB20_AVDD3V3 FEPHY_AVDD3V3	-0.3	TBD	V
Supply voltage for DDR IO	DDR_VDDQ DDR_VDDQL	-0.3	TBD	V
Storage Temperature	Tstg	NA	NA	°C
Max Conjunction Temperature	Tj	NA	NA	°C

### 3.2 Recommended Operating Conditions

The following table describes the recommended operating conditions.

Table 3-2 Recommended operating conditions

Parameters	Symbol	Min	Typ	Max	Unit
Voltage for CPU	CPU_DVDD	0.81	0.90	TBD	V
Voltage for GPU	GPU_DVDD	0.81	0.90	TBD	V
Voltage for LOGIC	LOGIC_DVDD	0.81	0.90	0.99	V
Voltage for PMU	PMU_LOGIC_DVDD	0.81	0.90	0.99	V
Voltage for PLL Analog (1.8V)	PMU_PLL_AVDD1V8 DDR_PLL_AVDD1V8	1.62	1.8	TBD	V
Voltage for GPIO (1.8V/3.3V)	VCCIOi(i=0~4)	1.62 3.0	1.8 3.3	1.98 3.465	V
Voltage for GPIO (3.3V only)	PMUIO_VCC3V3	3.0	3.3	3.465	V
Voltage for HDMI Analog (1.8V)	HDMI_TX_AVDD1V8	1.62	1.8	1.98	V
Voltage for USB Analog (1.8V)	USB20_AVDD1V8	1.62	1.8	1.98	V
Voltage for USB Analog (3.3V)	USB20_AVDD3V3	3.0	3.3	3.6	V
Voltage for FEPHY Analog (1.8V)	FEPHY_AVDD1V8	1.62	1.8	1.98	V
Voltage for FEPHY Analog (3.3V)	FEPHY_AVDD3V3	2.97	3.3	3.63	V
Voltage for OTP Analog(1.8V)	OTP_VCC1V8	1.62	1.8	1.98	V
Voltage for VDAC Analog(1.8V)	VDAC_AVDD1V8	1.62	1.8	1.98	V
Voltage for ACODEC Analog(1.8V)	ACODEC_AVDD1V8	1.62	1.8	1.98	V

Parameters	Symbol	Min	Typ	Max	Unit
Voltage for PCIE/U3 Analog(1.8V)	PCIE20_USB30_AVDD1V8	1.62	1.8	1.98	V
Voltage for SARADC Analog(1.8V)	SARADC_AVDD1V8	1.62	1.8	1.98	V
DDR3 IO VDDQ Voltage	DDR_VDDQ	1.425	1.5	1.575	V
DDR3L IO VDDQ Voltage	DDR_VDDQ	1.283	1.35	1.417	V
LPDDR3 IO VDDQ Voltage	DDR_VDDQ	1.14	1.2	1.3	V
DDR4 IO VDDQ Voltage	DDR_VDDQ	1.14	1.2	1.3	V
LPDDR4 IO VDDQ Voltage	DDR_VDDQ	1.06	1.1	1.17	V
LPDDR4X IO VDDQ Voltage	DDR_VDDQL	0.54	0.6	0.66	V
Max CPU frequency		NA	NA	TBD	GHz
Max GPU frequency		NA	NA	TBD	MHz
Ambient Operating Temperature	T <sub>A</sub>	0	NA	80	°C

### 3.3 DC Characteristics

Table 3-3 DC Characteristics

Parameters		Symbol	Min	Typ	Max	Unit
Digital GPIO @3.3V	Input Low Voltage	V <sub>il</sub>	-0.3	NA	0.8	V
	Input High Voltage	V <sub>ih</sub>	2.0	NA	VDDO+0.3	V
	Output Low Voltage	V <sub>ol</sub>	-0.3	NA	0.4	V
	Output High Voltage	V <sub>oh</sub>	2.4	NA	VDDO+0.3	V
	Pullup Resistor	R <sub>pu</sub>	16	26	43	Kohm
	Pulldown Resistor	R <sub>pd</sub>	16	26	43	Kohm
Digital GPIO @1.8V	Input Low Voltage	V <sub>il</sub>	-0.3	NA	0.35*VDDO	V
	Input High Voltage	V <sub>ih</sub>	0.65*VDDO	NA	VDDO+0.3	V
	Output Low Voltage	V <sub>ol</sub>	-0.3	NA	0.4	V
	Output High Voltage	V <sub>oh</sub>	1.4	NA	VDDO+0.3	V
	Pullup Resistor	R <sub>pu</sub>	16	26	43	Kohm
	Pulldown Resistor	R <sub>pd</sub>	16	26	43	Kohm

Parameters		Symbol	Min	Typ	Max	Unit
DDR IO @DDR3 mode	Input High Voltage	V <sub>ih_dds</sub>	V <sub>ref</sub> +0.1	NA	DDR_VDDQ	V
	Input Low Voltage	V <sub>il_dds</sub>	VSS	NA	V <sub>ref</sub> -0.1	V
	output impedance	R <sub>tt</sub>	20	NA	60	Ohm
DDR IO @DDR3L mode	Input High Voltage	V <sub>ih_dds</sub>	V <sub>ref</sub> +0.1	NA	DDR_VDDQ	V
	Input Low Voltage	V <sub>il_dds</sub>	VSS	NA	V <sub>ref</sub> -0.1	V
	output impedance	R <sub>tt</sub>	20	NA	60	Ohm
DDR IO @DDR4 mode	Input High Voltage	V <sub>ih_dds</sub>	V <sub>ref</sub> +0.1	NA	DDR_VDDQ	V
	Input Low Voltage	V <sub>il_dds</sub>	VSS	NA	V <sub>ref</sub> -0.1	V
	output impedance	R <sub>tt</sub>	20	NA	60	Ohm
DDR IO @ LPDDR3 mode	Input High Voltage	V <sub>ih_dds</sub>	V <sub>ref</sub> +0.1	NA	DDR_VDDQ	V
	Input Low Voltage	V <sub>il_dds</sub>	VSS	NA	V <sub>ref</sub> -0.1	V
	output impedance	R <sub>tt</sub>	20	NA	60	Ohm
DDR IO @LPDDR4 mode	Input High Voltage	V <sub>ih_dds</sub>	V <sub>ref</sub> +0.1	NA	DDR_VDDQ	V
	Input Low Voltage	V <sub>il_dds</sub>	VSS	NA	V <sub>ref</sub> -0.1	V
	output impedance	R <sub>tt</sub>	20	NA	60	Ohm
DDR IO @LPDDR4X mode	Input High Voltage	V <sub>ih_dds</sub>	V <sub>ref</sub> +0.1	NA	DDR_VDDQL	V
	Input Low Voltage	V <sub>il_dds</sub>	VSS	NA	V <sub>ref</sub> -0.1	V
	output impedance	R <sub>tt</sub>	20	NA	60	Ohm

### 3.4 Electrical Characteristics for General IO

Table 3-4 Electrical Characteristics for Digital General IO

Parameters		Symbol	Test condition	Min	Typ	Max	Unit
Digital GPIO @3.3V	Input leakage current	Ii	Vin = 3.3V or 0V	NA	NA	10	uA
	Tri-state output leakage current	Ioz	Vout = 3.3V or 0V	NA	NA	10	uA
	High level input current	Iih	Vin = 3.3V, pulldown disabled	NA	NA	10	uA
			Vin = 3.3V, pulldown enabled	NA	NA	10	uA
	Low level input current	Iil	Vin = 0V, pullup disabled	NA	NA	10	uA
Vin = 0V, pullup enabled			NA	NA	10	uA	
Digital GPIO @1.8V	Input leakage current	Ii	Vin = 1.8V or 0V	NA	NA	10	uA
	Tri-state output leakage current	Ioz	Vout = 1.8V or 0V	NA	NA	10	uA
	High level input current	Iih	Vin = 1.8V, pulldown disabled	NA	NA	10	uA
			Vin = 1.8V, pulldown enabled	NA	NA	10	uA
	Low level input current	Iil	Vin = 0V, pullup disabled	NA	NA	10	uA
Vin = 0V, pullup enabled			NA	NA	10	uA	

Note: VDDO and DVDD are both IO power Supply

### 3.5 Electrical Characteristics for PLL

Table 3-5 Electrical Characteristics for INT PLL

Parameters		Symbol	Test condition	Min	Typ	Max	Unit
	Input clock frequency(Frac)	F <sub>in</sub>	Fin = FREF @1.8V/0.99V	10	NA	800	MHz
	VCO operating range	F <sub>vco</sub>	Fvco = Fref * FBDIV @3.3V/0.99V	475	NA	1900	MHz
	Output clock frequency	F <sub>out</sub>	Fout = Fvco/POSTDIV @3.3V/0.99V	9	NA	1900	MHz
	Lock time	T <sub>lt</sub>	@ 3.3V/0.99V, FREF=24M,REFDIV=1	NA	1000	1500	Input clock cycles

Table 3-6 Electrical Characteristics for FRAC PLL

Parameters		Symbol	Test condition	Min	Typ	Max	Unit
	Input clock frequency(Frac)	F <sub>in</sub>	Fin = FREF @1.8V/0.99V	1	NA	1200	MHz
	VCO operating range	F <sub>vco</sub>	Fvco = Fref * FBDIV @3.3V/0.99V	950	NA	3800	MHz
	Output clock frequency	F <sub>out</sub>	Fout = Fvco/POSTDIV @3.3V/0.99V	19	NA	3800	MHz
	Lock time	T <sub>lt</sub>	@ 3.3V/0.99V, FREF=24M,REFDIV=1	NA	250	500	Input clock cycles

Notes:

- ① REF<sub>DIV</sub> is the input divider value;
- ② F<sub>B</sub><sub>DIV</sub> is the feedback divider value;
- ③ P<sub>O</sub><sub>ST</sub><sub>D</sub><sub>I</sub><sub>V</sub> is the output divider value

### 3.6 Electrical Characteristics for USB2.0 Interface

Table 3-7 Electrical Characteristics for USB2.0 Interface

Parameters	Symbol	Test condition	Min	Typ	Max	Unit
Transmitter						
Output resistance	R <sub>OUT</sub>	Classic mode (Vout = 0 or 3.3V)	40.5	45	49.5	ohms
		HS mode (Vout = 0 to 800mV)	40.5	45	49.5	ohms
Output Capacitance	C <sub>OUT</sub>	seen from D+ or D-			3	pF
Output Common Mode Voltage	V <sub>M</sub>	Classic (LS/FS) mode	1.45	1.65	1.85	V

Parameters	Symbol	Test condition	Min	Typ	Max	Unit
		HS mode	0.175	0.2	0.225	V
Differential output signal high	VOH	Classic (LS/FS); Io=0mA	2.97	3.3	3.63	V
		Classic (LS/FS); Io=6mA	2.2	2.7	NA	V
		HS mode; Io=0mA	360	400	440	mV
Differential output signal low	VOL	Classic (LS/FS); Io=0mA	-0.33	0	0.33	V
		Classic (LS/FS); Io=6mA	NA	0.3	0.8	V
		HS mode; Io=0mA	-40	0	40	mV
Receiver						
Receiver sensitivity	RSENS	Classic mode		±250		mV
		HS mode		±25		mV
Receiver common mode	RCM	Classic mode	0.8	1.65	2.5	V
		HS mode (differential and squelch comparator)	0.1	0.2	0.3	V
		HS mode (disconnect comparator)	0.5	0.6	0.7	V
Input capacitance (seen at D+ or D-)			NA	NA	3	pF
Squelch threshold			100	NA	150	mV
Disconnect threshold			570	600	664	mV

### 3.7 Electrical Characteristics for HDMI

Table 3-8 Electrical Characteristics for HDMI

Parameters	Symbol	Test condition	Min	Typ	Max	Unit
Differential output signal rise time	tR	20~80% RL=50Ω	75	NA	NA	ps
	tR_DATA	20~80% RL=50Ω	42.5	NA	NA	ps
	tR_CLOCK	20~80% RL=50Ω	75	NA	NA	ps
Differential output signal fall time	tF	20~80% RL=50Ω	75	NA	NA	ps
	tF_DATA	20~80% RL=50Ω	42.5	NA	NA	ps
	tF_CLOCK	20~80% RL=50Ω	75	NA	NA	ps

### 3.8 Electrical Characteristics for Audio CODEC interface

Table 3-9 Electrical Characteristics for Audio CODEC

Test conditions: AVDD = 1.8V, DVDD = 0.8V, TA = 25°C, 1KHz Sine Input, Fs = 48KHz

Parameters	Symbol	Test condition	Min	Typ	Max	Units
Operating Condition						
Analog Supply	AVDD		1.62	1.8	1.98	V
DAC Line Output						
Programmable Gain	G <sub>DRV</sub>		-39	NA	6	dB
Gain Step Size			NA	1.5	NA	dB
Signal to Noise Ratio	SNR	A-weighted	NA	93	NA	dB
Total Harmonic Distortion	THD	-3dBFS output 600Ω load	NA	-84	NA	dB
Power Supply Rejection	PSRR	1KHz	NA	55	NA	dB
Power Consumption						
Standby			NA	0.05	NA	mA
Stereo Playback		Quiescent output	NA	5	NA	mA

### 3.9 Electrical Characteristics for SARADC

Table 3-10 Electrical Characteristics for SARADC

Parameters	Symbol	Test condition	Min	Typ	Max	Unit
Resolution			NA	10	NA	bit
Effective Number of Bit	ENOB		NA	9	NA	bit
Differential Non-Linearity	DNL		-1	NA	+1	LSB
Integral Non-Linearity	INL		-2	NA	+2	LSB
Input Capacitance	C <sub>IN</sub>		NA	8	NA	pF
Sampling Rate	f <sub>S</sub>		NA	NA	1	MS/s
Spurious Free Dynamic Range	SFDR	f <sub>S</sub> =1MS/S f <sub>OUT</sub> =1.17KHz	NA	61	NA	dB
Signal to Noise and Harmonic Ratio	SNDR		NA	56	NA	dB

### 3.10 Electrical Characteristics for TSADC

Table 3-11 Electrical Characteristics for TSADC

Parameters	Symbol	Test condition	Min	Typ	Max	Unit
Accuracy from -40°C to 125°C	T <sub>JACC</sub>		NA	NA	±3	°C
Sensing Temperature Range	T <sub>RANGE</sub>		-40	NA	125	°C
Resolution	T <sub>LSB</sub>		NA	0.6	NA	°C

## Chapter 4 Thermal Management

### 4.1 Overview

For reliability and operability concerns, the absolute maximum junction temperature has to be below 125°C.

### 4.2 Package Thermal Characteristics

Table 4-1 provides the thermal resistance characteristics for the package used on the SoC. The resulting simulation data for reference only, please prevail in kind test.

Table 4-1 Thermal Resistance Characteristics

Parameter	Symbol	Typical	Unit
Junction-to-ambient thermal resistance	$\theta_{JA}$	22.8	(°C/W)
Junction-to-board thermal resistance	$\theta_{JB}$	9.3	(°C/W)
Junction-to-case thermal resistance	$\theta_{JC}$	6.87	(°C/W)

Note: The PCB is 4 layers, 114.3 mm.\*101.6 mm