

# Rockchip RK628E Datasheet

## Revision History

Date	Revision	Description
2024-07-02	1.4	Update the parameters in 3.1 Absolute Maximum Ratings and 3.2 Recommended Operating Condition
2022-01-05	1.3	Update the description
2021-08-01	1.2	Update the description
2020-06-01	1.1	Update the description
2020-04-13	1.0	Initial released

# Table of Content

Table of Content .....2

Figure Index .....3

Table Index.....4

Warranty Disclaimer.....5

    Chapter 1 Introduction ..... 6

        1.1 Features .....6

        1.2 Block Diagram .....8

    Chapter 2 Package Information..... 9

        2.1 Order Information .....9

        2.2 Top Marking .....9

        2.3 Package Information.....9

        2.4 TFBGA144 Dimension .....9

        2.5 TFBGA144 Pin Number Order ..... 11

        2.6 TFBGA144 Ball Map ..... 13

        2.7 Pin Description..... 13

        2.8 RK628E Power/Ground IO Description ..... 13

        2.9 RK628E Function IO Description ..... 14

        2.10 IO Pin Name Description..... 16

        2.11 RK628E IO Type ..... 17

    Chapter 3 Electrical Specification .....19

        3.1 Absolute Maximum Ratings ..... 19

        3.2 Recommended Operating Condition ..... 19

        3.3 DC Characteristics ..... 19

        3.4 Recommended Operating Frequency ..... 20

## **Figure Index**

Fig. 1-1 RK628E Block Diagram .....	8
Fig. 2-1 RK628E Package definition .....	9
Fig. 2-2 RK628E TFBGA144 Package Top View and bottom View .....	9
Fig. 2-3 RK628E TFBGA144 Package side View.....	10
Fig. 2-4 RK628E TFBGA144 Package side View.....	10
Fig. 2-5 RK628E TFBGA144 Package Dimension .....	10
Fig. 2-6 RK628E BGA144 Ball Map .....	13

## Table Index

Table 1-1 RK628E video input interface.....	6
Table 1-2 RK628E video output interface.....	7
Table 2-1 RK628E TFBGA144 Pin Number Order Information.....	11
Table 2-2 RK628E Power/Ground IO Information for BGA628 .....	13
Table 2-3 RK628E Function IO Description.....	14
Table 2-4 RK628E IO Function Description List.....	16
Table 2-5 RK628E IO Type List.....	17
Table 3-1 RK628E Absolute Maximum Ratings.....	19
Table 3-2 RK628E Recommended Operating Condition .....	19
Table 3-3 RK628E DC Characteristics.....	19
Table 3-4 RK628E Recommended Operating Frequency .....	20

## Warranty Disclaimer

Copyright © 2024 Rockchip Electronics Co., Ltd. All rights reserved.

No part of this document may be reproduced, transmitted or used in any form or by any means without the written prior consent of Rockchip Electronics Co., Ltd.

### Trademark

Rockchip is a registered trademark of Rockchip Electronics Co., Ltd. in the People's Republic of China and other countries/areas. Other brands, product names mentioned in this document are the property of their respective owners.

### Disclaimer

Rockchip Electronics Co., Ltd. ("Rockchip") may make changes to any information in this document at any time without any prior notice.

Information in this document is provided just as a reference or typical applications. All or part of product features described in this document may not be within the purchase scope or the usage scope, and may be subject to the third party licensing requirements. All statements, information in this document is provided "AS IS" without warranties of any kind, either express or implied. Actual performance of Rockchip products may vary in different applications. Third party licenses maybe required to use some features supported by Rockchip products. Customers shall be solely and exclusively responsible to obtain all appropriately required third party licenses prior to its such use. Should customers use the features supported by Rockchip products without any required third party license, customers shall indemnify and hold Rockchip and its subsidiaries, affiliates as well as distributors harmless against all claims, costs, damages, and expenses, and reasonable attorney fees arising out of any claim associated with such unauthorized use.

Rockchip products are not intended for use in military, airplane, medical devices, lifesaving or life sustaining applications ("Unintended Uses"). Customers shall take any and all actions to ensure using Rockchip products in a lawful manner and shall be liable for Unintended Uses.

## Chapter 1 Introduction

RK628E is a high-integration interface chip, which can support HDMI /parallel RGB /BT.1120 as input and dual MIPI/dual LVDS/GVI(general video interface)/parallel RGB/ BT.1120 as output with featured scaler inside. The key application scenario is extension of display output port for original application processor such as RK3288 /RK3399, or HDMI in interface providing.

### 1.1 Features

#### 1.1.1 Video input interface

- HDMI RX interface
  - Compliant with HDMI 1.4/HDMI 2.0
  - Supports HDCP 1.4
  - Supports 8/10bit per component video format
  - Supports rgb888/yuv444/yuv422/yuv420
  - Supports Max resolution 4096x2304@60fps
  - Supports data rates up to 300MHZ,with phy bit rate 3Gbps per lane
  - Supports DDC Bus I2C master interface at 3.3/5V
  - Supports EDID and CEC function
- Parallel IN interface
  - Supports Max resolution 1080p@60fps
  - Supports 16bits BT.1120 in
  - Supports 24bits parallel RGB in

Table 1-1 RK628E video input interface

Interface	Resolution	Data rate	Bit rate per lane
HDMI	4096x2304@60	NA	3Gbps
BT.1120	1080p@60fps	148.5M	NA
RGB	1080p@60fps	148.5M	NA

#### 1.1.2 Video output interface

- HDMI TX interface
  - Supports all DTV resolutions including 720p /1080p
  - Supports data rate from 25MHz, 1.65bps up to 3.4Gbps over a Single channel HDMI Internal SRAM
  - TMDS Tx Drivers with programmable output swing, resister values and pre-emphasis
  - DDC Bus I2C master interface at 3.3/5V
  - The EDID and CEC function are also supported by HDMI Transmitter Controller
- MIPI TX interface
  - DSI
    - ◆ Compliant with MIPI DPHY V1.2
    - ◆ Support the DPI interface color coding mappings into 24-bit Interface
    - ◆ Up to 4 D-PHY Data Lanes per channel
    - ◆ Supports data rate up to 1.2Gbps
    - ◆ Supports dual channel DSI
  - CSI
    - ◆ Compliant with MIPI DPHY V1.2
    - ◆ Support format: YUV422
    - ◆ Up to 4 D-PHY Data Lanes
    - ◆ Supports data rate up to 1.2Gbps
    - ◆ Supports single channel
- GVI TX interface
  - Supports RGB666/RGB888/RGB101010/YUV422-8bit/YUV422-10bit format
  - Supports Max resolution 4096x2304@60fps
  - Supports up to 3.75Gbps data rate(effective data rate 3Gbps)
  - Supports 1/2/4/8 lanes

- Supports output lanes flexible mapping
- Supports 1/2 section mode
- LVDS TX interface
  - Compliant with the Standard TIA/EIA-644-A LVDS standard
  - Supports data rate up to 1Gbps
  - Support 8bit format-1, format-2, format-3 display mode, Support 6bit display mode.
  - Supports dual channel LVDS
- Parallel OUT interface
  - Supports Max resolution 1080p@60fps
  - Supports 16bits BT.1120 out
  - Supports 24bits parallel RGB out

Table 1-2 RK628E video output interface

Interface	Resolution	Data rate	Bit rate per lane
GVI	4096x2304@60fps	NA	3.75Gbps
Dual MIPI DSI	2560x1600@60fps	NA	1.2Gbps
MIPI DSI	1080p@60fps	NA	1.2Gbps
MIPI CSI	3840x2160@30fps	NA	1.2Gbps
Dual LVDS	1080p@60fps	NA	1 Gbps
LVDS	720p@60fps	NA	1.Gbps
BT.1120	1080p@60fps	148.5M	NA
RGB	1080p@60fps	148.5M	NA
HDMI	1080p@60fps	148.5M	NA

### 1.1.3 TX/RX adapter

- Interaction of HDP signal between HDMI TX and HDMI RX
- Support HDMI TX CEC function
- Support RX HDCP1.4 inside-key memory. It is readable and writable
- Support HDMI RX/TX
- Support on-chip EDID memory. It is readable and writable

### 1.1.4 Post process

- CSC
  - RGB2YUV
  - YUV2RGB
  - YUV2VYU
- Display interface
  - Parallel display Interface: 30-bit(RGB/YUV)
  - Asynchronous output pixel clock (PLL required)
  - Flexible display timing setting
  - Configurable border black area
- Scaling down
  - Max input resolution: 4096x2304
  - Arbitrary non-integer scaling ratio
  - Support two mode: bilinear and average
  - Max 1/4 scaling ratio for bilinear scaling down
  - Max 1/6 scaling ratio for average scaling down
- Scaling up
  - Max output resolution: 4096x2304
  - Arbitrary non-integer scaling ratio
  - Support four scaling up mode for different effect
  - Max 6 scaling ratio
- Split
  - Left-right mode
  - Odd-even mode

### 1.1.5 Others

- Audio
  - Support HDMI RX I2S interface, up to 192kHz sample rate, 8 channel

- Support I/O I2S interface, 8 channel
- Support HDMI TX I2S interface, 8 channel
- Support the connection of RX and TX's I2S
- EFUSE
  - One-time programmable nonvolatile EFUSE storage cells organized as 64x8 bits
  - 1.1V typical core voltage
  - AVDD is NOT allowed to exceed 2.75V
  - Burning requirements:
    - ◆ 2.5V typical burning voltage (AVDD), AVDD must be high during PGM mode. AVDD must be low or floating during READ mode and inactive mode
    - ◆ 2us burning pulse width
    - ◆ Ambient temperature range of 10~40°C
    - ◆ Burning at wafer, package, or field level
- Package Type
  - BGA144

## 1.2 Block Diagram

The following figure shows the basic block diagram for RK628E.

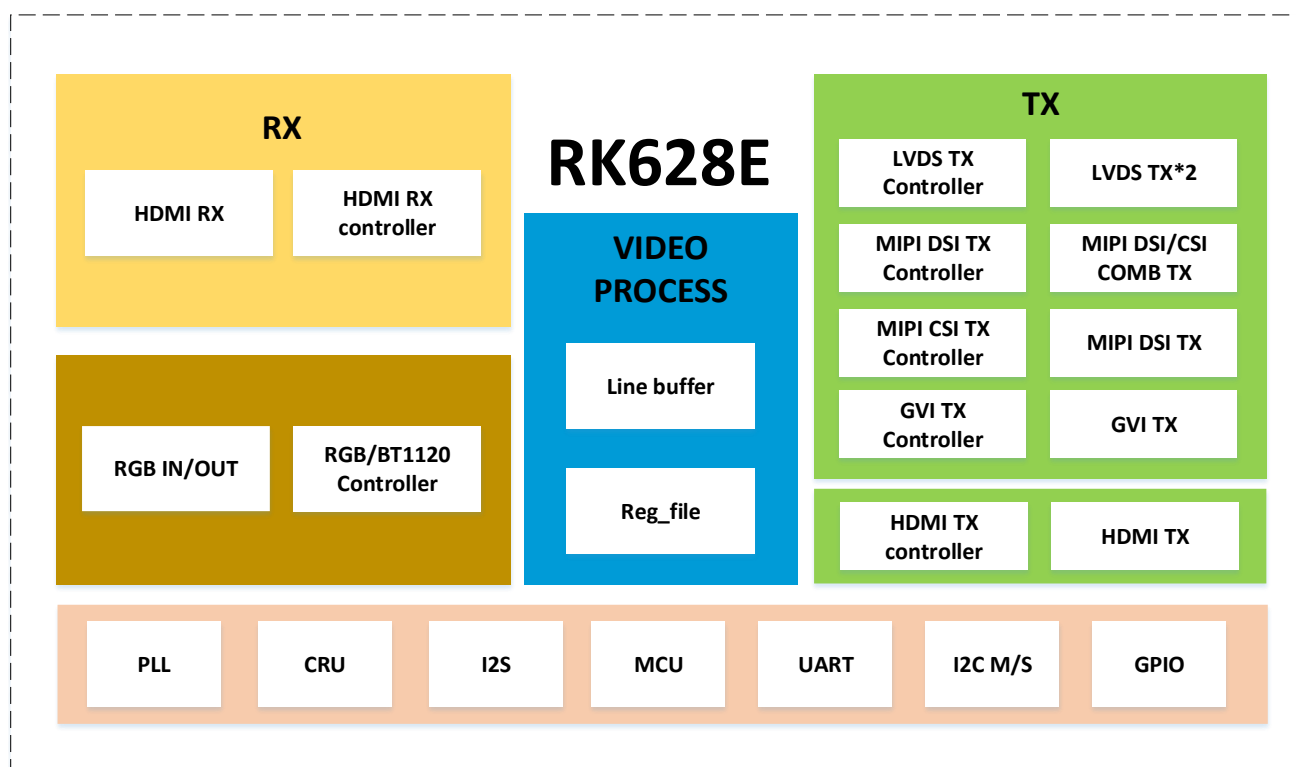

Fig. 1-1 RK628E Block Diagram

## Chapter 2 Package Information

### 2.1 Order Information

Orderable Device	RoHS status	Package	Package Qty	Device Feature
RK628E	RoHS	TFBGA144	3480pcs	High speed interface bridge chip

### 2.2 Top Marking

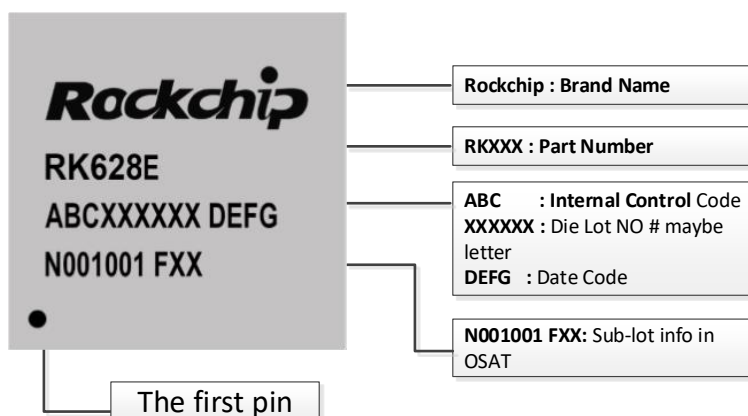

Fig. 2-1 RK628E Package definition

### 2.3 Package Information

BGA144(body: 8mmx8mm; ball size: 0.3mm; ball pitch: 0.65mm)

### 2.4 TFBGA144 Dimension

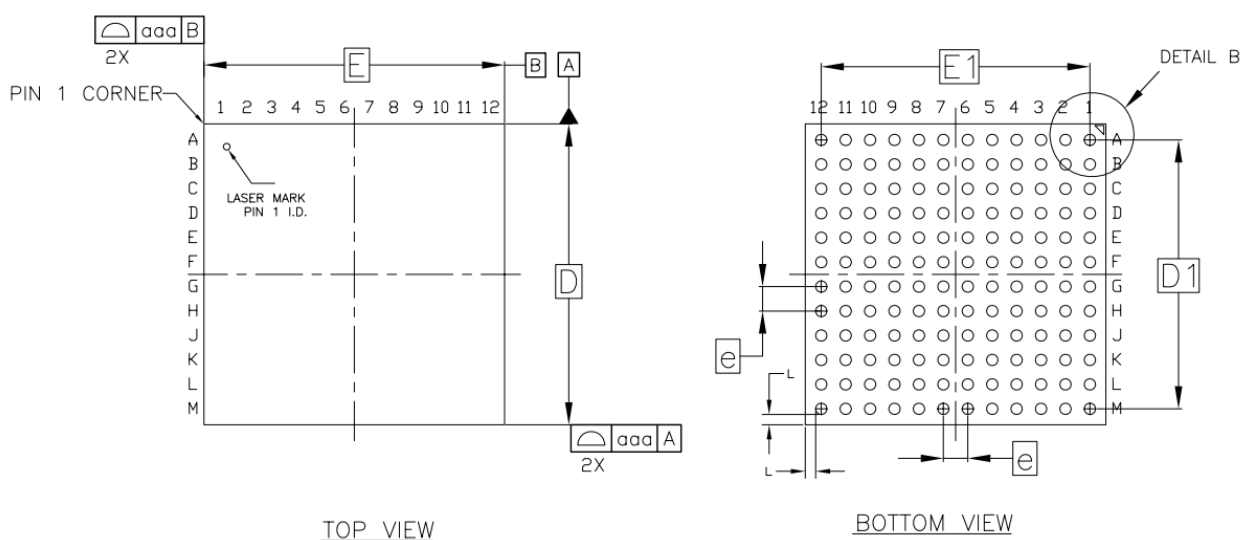

Fig. 2-2 RK628E TFBGA144 Package Top View and bottom View

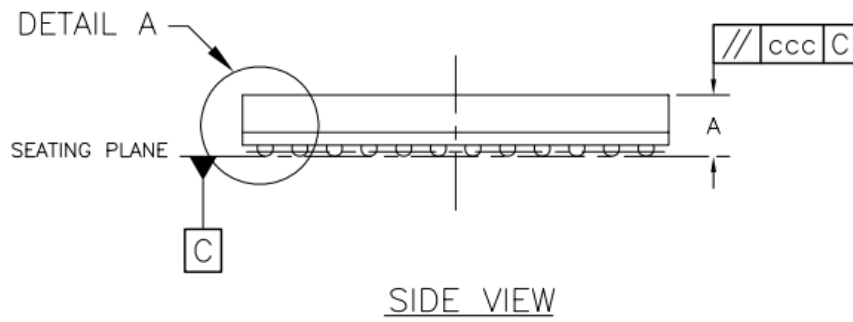

Fig. 2-3 RK628E TFBGA144 Package side View

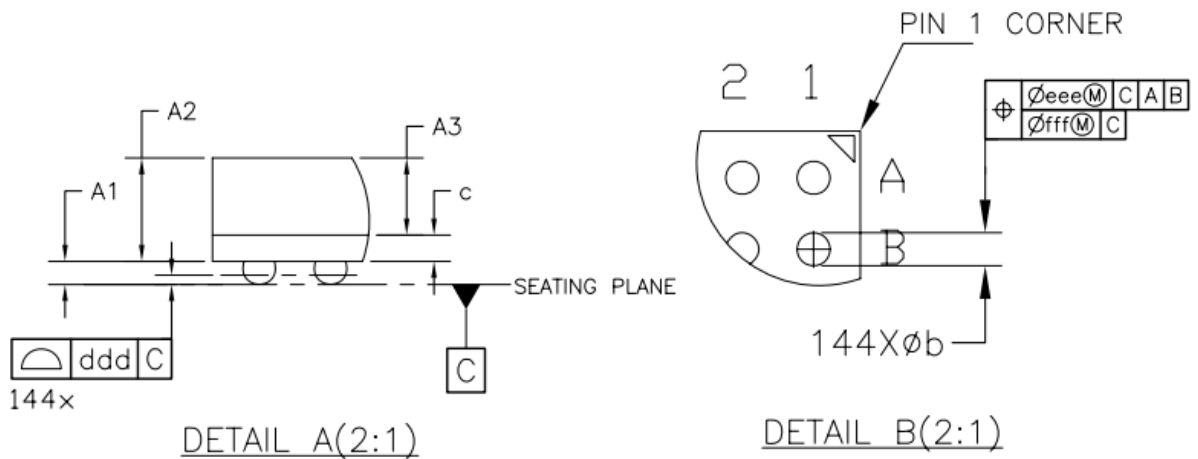

Fig. 2-4 RK628E TFBGA144 Package side View

SYMBOL	MILLIMETER		
	MIN	NOM	MAX
A	--	1.15	1.23
A1	0.16	0.21	0.26
A2	0.89	0.94	0.99
A3	0.70 BASIC		
c	0.20	0.24	0.28
D	7.90	8.00	8.10
D1	7.15 BASIC		
E	7.90	8.00	8.10
E1	7.15 BASIC		
e	0.65 BASIC		
b	0.25	0.30	0.35
L	0.275 REF		
aaa	0.15		
ccc	0.15		
ddd	0.10		
eee	0.15		
fff	0.08		

Fig. 2-5 RK628E TFBGA144 Package Dimension

Note:

1. CONTROLLING DIMENSION: MILLIMETER.

2. PRIMARY DATUM C AND SEATING PLANE ARE DEFINED BY THE SPHERICAL CROWNS OF THE SOLDER BALLS.
3. DIMENSION *b* IS MEASURED AT THE MAXIMUM SOLDER BALL DIAMETER, PARALLEL TO PRIMARY DATUM C.
4. SPECIAL CHARACTERISTICS C CLASS: A, *ddd*.
5. THE PATTERN OF PIN 1 FIDUCIAL IS FOR REFERENCE ONLY.
6. THE TILT OF HEAT SINK SHOULD BE WITHIN 10MIL(0.254mm) (VERTICAL POSITION).

## 2.5 TFBGA144 Pin Number Order

Table 2-1 RK628E TFBGA144 Pin Number Order Information

Pin Number	Pin Name	Pin Number	Pin Name
A1	VSS_1	G1	GVI/LVDS/MIPI_TX0N
A2	GVI/LVDS/MIPI_TX5P	G2	GVI/LVDS/MIPI_TX0P
A3	GVI/LVDS/MIPI_TX6P	G3	VSS_25
A4	GVI/LVDS/MIPI_TX7P	G4	VSS_19
A5	GVI/LVDS/MIPI_TX8P	G5	VSS_9
A6	GVI/LVDS/MIPI_TX9P	G6	VSS_13
A7	GPIO3_B1/GVI_HPD	G7	VSS_16
A8	GPIO3_A1/VOP_HSYNC	G8	VSS_20
A9	VOP_DCLK	G9	HDMIRX_EXTR
A10	GPIO2_C4/VOP_D20/JTAGTDI	G10	GPIO2_A0/VOP_D0
A11	GPIO2_C1/VOP_D17/XIPSFCMISO	G11	GPIO2_A1/VOP_D1
A12	VSS_2	G12	GPIO2_A2/VOP_D2
B1	GVI/LVDS/MIPI_REXT	H1	GPIO0_A7/I2S_D3_M0/UARTTRTSN
B2	GVI/LVDS/MIPI_TX5N	H2	GPIO0_A6/I2S_D2_M0/UARTCTSN
B3	GVI/LVDS/MIPI_TX6N	H3	GPIO0_A5/I2S_D1_M0/UARTRX
B4	GVI/LVDS/MIPI_TX7N	H4	RESETN
B5	GVI/LVDS/MIPI_TX8N	H5	VCCIO1
B6	GVI/LVDS/MIPI_TX9N	H6	VSS_29
B7	GPIO3_B2/GVI_LOCK	H7	GPIO1_A0/TEST_CLKO
B8	GPIO3_A3/VOP_VSYNC	H8	GPIO1_A1/SFC_CSLK
B9	GPIO3_A0/VOP_DEN	H9	HDMIRX_DVDD_1V1_1
B10	GPIO2_C3/VOP_D19/JTAGTDO	H10	VSS_18
B11	GPIO2_C0/VOP_D16/XIPSFCCSN	H11	HDMIRX_D2N
B12	GPIO2_B7/VOP_D15	H12	HDMIRX_D2P
C1	GVI/LVDS/MIPI_TX4N	J1	GPIO0_A3/I2S_LRCK_M0
C2	GVI/LVDS/MIPI_TX4P	J2	GPIO0_A2/I2S_SCK_M0
C3	GVI/LVDS/MIPI_PLL_AVDD_3V3	J3	INT/SPIBOOT
C4	VSS_26	J4	HDMITX_DVDD_1V1_2
C5	GVI/LVDS/MIPI_AVDD_1V1_3	J5	HDMITX_DVDD_1V1_3
C6	VSS_27	J6	HDMITX_DVDD_1V1_1
C7	I2C_ADDR	J7	PLL_AVDD_1V1
C8	GPIO2_C7/VOP_D23/JTAGTRSN	J8	EFUSE_VDD_2V5
C9	GPIO2_C6/VOP_D22/JTAGTCK	J9	HDMIRX_DVDD_1V1_2
C10	GPIO2_C2/VOP_D18/XIPSFCMOSI	J10	HDMIRX_AVDD_3V3_1
C11	GPIO2_B4/VOP_D12	J11	HDMIRX_D1N
C12	GPIO2_B6/VOP_D14	J12	HDMIRX_D1P
D1	GVI/LVDS/MIPI_TX3N	K1	GPIO0_B1/HDMITX_SDA
D2	GVI/LVDS/MIPI_TX3P	K2	GPIO0_A4/I2S_D0_M0/UARTTX
D3	VSS_5	K3	I2C_SDA
D4	GVI/LVDS/MIPI_AVDD_1V1_1	K4	HDMITX_AVDD_3V3
D5	GVI/LVDS/MIPI_AVDD_3V3_1	K5	VSS_7
D6	VSS_24	K6	VSS_22
D7	TEST	K7	VSS_10
D8	DVDD_2	K8	GPIO1_B0/HDMIRX_HPD_M0

Pin Number	Pin Name	Pin Number	Pin Name
D9	GPIO2_C5/VOP_D21/JTAGTMS	K9	GPIO1_B3/HDMIRX_CEC_M0
D10	GPIO2_B2/VOP_D10	K10	VSS_23
D11	GPIO2_B3/VOP_D11	K11	HDMIRX_D0N
D12	GPIO2_B5/VOP_D13	K12	HDMIRX_D0P
E1	GVI/LVDS/MIPI_TX2N	L1	GPIO0_B2/HDMITX_SCL
E2	GVI/LVDS/MIPI_TX2P	L2	GPIO0_B0/HDMITX_HPD
E3	GVI/LVDS/MIPI_AVDD_1V1_2	L3	I2C_SCL
E4	GVI/LVDS/MIPI_AVDD_3V3_2	L4	HDMITX_CLKN
E5	VSS_11	L5	HDMITX_D0N
E6	VSS_14	L6	HDMITX_D1N
E7	VSS_28	L7	HDMITX_D2N
E8	VCCIO2_1	L8	GPIO1_B2/HDMIRX_SCL_M0
E9	DVDD_1	L9	OSC_OUT
E10	GPIO2_A7/VOP_D7	L10	VSS_28
E11	GPIO2_B1/VOP_D9	L11	HDMIRX_CLKN
E12	GPIO2_B0/VOP_D8	L12	HDMIRX_CLKP
F1	GVI/LVDS/MIPI_TX1N	M1	VSS_4
F2	GVI/LVDS/MIPI_TX1P	M2	GPIO0_B3/HDMITX_CEC
F3	GVI/LVDS/MIPI_AVDD_1V1_4	M3	HDMITX_EXTR
F4	VSS_6	M4	HDMITX_CLKP
F5	VSS_8	M5	HDMITX_D0P
F6	VSS_12	M6	HDMITX_D1P
F7	VSS_15	M7	HDMITX_D2P
F8	VCCIO2_2	M8	GPIO1_B1/HDMIRX_SDA_M0
F9	GPIO2_A3/VOP_D3	M9	OSC_IN
F10	GPIO2_A6/VOP_D6	M10	PLL_AVDD
F11	GPIO2_A5/VOP_D5	M11	VSS_29
F12	GPIO2_A4/VOP_D4	M12	VSS_3

## 2.6 TFBGA144 Ball Map

144	1	2	3	4	5	6	7	8	9	10	11	12
A	VSS_1	GVILVDSMIPL_TX 5P	GVILVDSMIPL_TX 6P	GVILVDSMIPL_TX 7P	GVILVDSMIPL_TX 8P	GVILVDSMIPL_TX 9P	GPIO3_B1/GVL_H PD	GPIO3_A1/VOP_H SYNC	VOP_DCLK	GPIO2_C4/VOP_D 20/UART_RX_M0/ TAG_TDI	GPIO2_C1/VOP_D 17/XIPSPFC_MISO	VSS_2
B	GVILVDSMIPL_RE XT	GVILVDSMIPL_TX 5N	GVILVDSMIPL_TX 6N	GVILVDSMIPL_TX 7N	GVILVDSMIPL_TX 8N	GVILVDSMIPL_TX 9N	GPIO3_B2/GVL_LO CK	GPIO3_A3/VOP_V SYNC	GPIO3_A0/VOP_D EN	GPIO2_C3/VOP_D 19/UART_TX_M0/ TAG_TDO	GPIO2_C0/VOP_D 16/XIPSPFC_CSN	GPIO2_B7/VOP_D 15
C	GVILVDSMIPL_TX 4N	GVILVDSMIPL_TX 4P	GVILVDSMIPL_PL L_AVDD_3V3	VSS_26	GVILVDSMIPL_AV DD_1V1_3	VSS_27	I2C_ADDR	GPIO2_C7/VOP_D 23/UART_TRSTN	GPIO2_C6/VOP_D 22/UART_RTSN_ M0/UART_TCK	GPIO2_C2/VOP_D 18/XIPSPFC_MOSI	GPIO2_B4/VOP_D 12	GPIO2_B6/VOP_D 14
D	GVILVDSMIPL_TX 3N	GVILVDSMIPL_TX 3P	VSS_5	GVILVDSMIPL_AV DD_1V1_1	GVILVDSMIPL_AV DD_3V3_1	VSS_24	TEST	DVDD_2	GPIO2_C5/VOP_D 21/UART_CTSN_ M0/UART_TMS	GPIO2_B2/VOP_D 10	GPIO2_B3/VOP_D 11	GPIO2_B5/VOP_D 13
E	GVILVDSMIPL_TX 2N	GVILVDSMIPL_TX 2P	GVILVDSMIPL_AV DD_1V1_2	GVILVDSMIPL_AV DD_3V3_2	VSS_11	VSS_14	VSS_21	VCCIO2_1	DVDD_1	GPIO2_A7/VOP_D 7	GPIO2_B1/VOP_D 9	GPIO2_B0/VOP_D 8
F	GVILVDSMIPL_TX 1N	GVILVDSMIPL_TX 1P	GVILVDSMIPL_AV DD_1V1_4	VSS_6	VSS_8	VSS_12	VSS_15	VCCIO2_2	GPIO2_A3/VOP_D 3	GPIO2_A6/VOP_D 6	GPIO2_A5/VOP_D 5	GPIO2_A4/VOP_D 4
G	GVILVDSMIPL_TX 0N	GVILVDSMIPL_TX 0P	VSS_25	VSS_19	VSS_9	VSS_13	VSS_16	VSS_20	HDMIRX_EXTR	GPIO2_A0/VOP_D 0	GPIO2_A1/VOP_D 1	GPIO2_A2/VOP_D 2
H	GPIO0_A7/I2S_D3 _M0/UART_RTSN_ _M1	GPIO0_A6/I2S_D2 _M0/UART_CTSN_ _M1	GPIO0_A5/I2S_D1 _M0/UART_RX_M 1	RSETN	VCCIO1	VSS_17	GPIO1_A0/TEST_ CLKO	GPIO1_A1/XIPSPFC_ CSLK	HDMIRX_DVDD_1 V1_1	VSS_18	HDMIRX_D2N	HDMIRX_D2P
J	GPIO0_A3/I2S_LR CK_M0	GPIO0_A2/I2S_SC K_M0	GPIO0_B4/INT/SP I_BOOT	HDMITX_DVDD_1 V1_2	HDMITX_DVDD_1 V1_3	HDMITX_DVDD_1 V1_1	PLL_AVDD_1V1	EFUSE_VDD_2V5	HDMIRX_DVDD_1 V1_2	HDMIRX_AVDD_3 V3_1	HDMIRX_D1N	HDMIRX_D1P
K	GPIO0_B1/HDMIT X_SDA	GPIO0_A4/I2S_D0 _M0/UART_TX_M1	GPIO1_B5/I2CS_S _DAI2CM_SDA	HDMITX_AVDD_3 V3	VSS_7	VSS_22	VSS_10	GPIO1_B0/HDMIR X_HPD_M0	GPIO1_B3/HDMIR X_CEC_M0	VSS_23	HDMIRX_D0N	HDMIRX_D0P
L	GPIO0_B2/HDMIT X_SCL	GPIO0_B0/HDMIT X_HPD	GPIO1_B4/I2CS_S _CL/I2CM_SCL	HDMITX_CLKN	HDMITX_D0N	HDMITX_D1N	HDMITX_D2N	GPIO1_B2/HDMIR X_SCL_M0	OSC_OUT	VSS_28	HDMIRX_CLKN	HDMIRX_CLKP
M	VSS_4	GPIO0_B3/HDMIT X_CEC	HDMITX_EXTR	HDMITX_CLKP	HDMITX_D0P	HDMITX_D1P	HDMITX_D2P	GPIO1_B1/HDMIR X_SDA_M0	OSC_IN	PLL_AVDD	VSS_29	VSS_3

Fig. 2-6 RK628E BGA144 Ball Map

## 2.7 Pin Description

In this chapter, the pin description will be divided into two parts, one is all power/ground descriptions in Table 2-2 for BGA144, include analog power/ground; another is all the function signals descriptions in Table 2-2, also include analog function signals.

## 2.8 RK628E Power/Ground IO Description

Table 2-2 RK628E Power/Ground IO Information for BGA628

Group	Ball#	Descriptions
VSS	A1,A12, C4,C6,D3,D6, E5,E6,E7, F4,F5,F6,F7, G3,G4,G5,G6,G7,G8 H6, H10, K5,K6,K7,K10, M1,M12	Ground
DVDD	D8,E9	Digital 1.1v power
VCCIO1	H5	IO1 3.3v power
VCCIO2	E8,F8	IO2 3.3v power

Group	Ball#	Descriptions
PLL_AVDD	M10	PLL analog 3.3v power
PLL_AVDD_1V1	J7	PLL analog 1.1v power
EFUSE_VDD_2V5	J8	EFUSE 2.5v power
GVI/LVDS/MIPI_PLL_AVDD_3V3	C3	TX PHY PLL Power
GVI/LVDS/MIPI_AVDD_3V3	D5,E4	TX PHY 3.3v Power
GVI/LVDS/MIPI_AVDD_1V1	C5,D4,E3,F3	TX PHY 1.1v Power
HDMITX_DVDD_1V1	J4,J5,J6	HDMI TX digital 1.1v power
HDMITX_AVDD_3V3	K4	HDMI TX analog 3.3v power
HDMIRX_DVDD_1V1	H9,J9	HDMI RX PHY 1.1v power
HDMIRX_AVDD_3V3	J10	HDMI RX PHY 3.3v power

## 2.9 RK628E Function IO Description

Table 2-3 RK628E Function IO Description

Pad#	Ball#	func1	func2	func3	Pad Type <sup>o</sup>	Drive Strength <sup>o</sup>	Pull	Reset State <sup>o</sup>	Power Supply
OSC_IN	M9				H	2	NA	I	
OSC_OUT	L9				H	2	NA	O	
RESETN	H4				B	2	Up	I	
TEST	D7				B	2	down	I	
I2C_ADDR	C7				B	4	down	I	
I2C_SCL	L3				G	4	up	I	
I2C_SDA	K3				G	4	up	I	
INT	J3				B	2	down	I	
GPIO0_A2/I2S_SCK_M0	J2	I2S_SCK_M0			D	12	down	I	
GPIO0_A3/I2S_LRCK_M0	J1	I2S_LRCK_M0			B	12	down	I	
GPIO0_A4/I2S_D0_M0/UA_RTTX	K2	I2S_D0_M0			B	12	down	I	
GPIO0_A5/I2S_D1_M0/UA_RTRX	H3	I2S_D1_M0			B	12	down	I	
GPIO0_A6/I2S_D2_M0/UA_RTCTSN	H2	I2S_D2_M0			B	12	down	I	
GPIO0_A7/I2S_D3_M0/UA_RTRTSN	H1	I2S_D3_M0			B	12	down	I	
GPIO0_B0/HDMITX_HPD	L2	HDMITX_HPD			E	4	down	I	
GPIO0_B1/HDMITX_SDA	K1	HDMITX_SDA			G	4	up	I	
GPIO0_B2/HDMITX_SCL	L1	HDMITX_SCL			G	4	up	I	
GPIO0_B3/HDMITX_CEC	M2	HDMITX_CEC			G	4	up	I	
GPIO1_A0/TEST_CLKO	H7	TEST_CLKO			B	4	down	I	
GPIO1_A1/SFC_CLK	H8	SFC_CLK			B	4	down	I	
GPIO1_B0/HDMIRX_HPD_M0	K8	HDMIRX_HPD_M0			F	4	up	I	
GPIO1_B1/HDMIRX_SDA_M0	M8	HDMIRX_SDA_M0			G	4	up	I	
GPIO1_B2/HDMIRX_SCL_M0	L8	HDMIRX_SCL_M0			G	4	up	I	
GPIO1_B3/HDMIRX_CEC_M0	K9	HDMIRX_CEC_M0			G	4	up	I	
GPIO2_A0/VOP_D0	G10	VOP_D0			I	12	down	I	GPIO
GPIO2_A1/VOP_D1	G11	VOP_D1			I	12	down	I	
GPIO2_A2/VOP_D2	G12	VOP_D2			I	12	down	I	
GPIO2_A3/VOP_D3	F9	VOP_D3			I	12	down	I	
GPIO2_A4/VOP_D4	F12	VOP_D4			I	12	down	I	
GPIO2_A5/VOP_D5	F11	VOP_D5			I	12	down	I	
GPIO2_A6/VOP_D6	F10	VOP_D6			I	12	down	I	
GPIO2_A7/VOP_D7	E10	VOP_D7			I	12	down	I	
GPIO2_B0/VOP_D8	E12	VOP_D8			I	12	down	I	
GPIO2_B1/VOP_D9	E11	VOP_D9			I	12	down	I	
GPIO2_B2/VOP_D10	D10	VOP_D10			I	12	down	I	

Pad#	Ball#	func1	func2	func3	Pad Type <sup>o</sup>	Drive Strength <sup>o</sup>	Pull	Reset State <sup>o</sup>	Power Supply
GPIO2_B3/VOP_D11	D11	VOP_D11			I	12	down	I	Power Supply
GPIO2_B4/VOP_D12	C11	VOP_D12			I	12	down	I	
GPIO2_B5/VOP_D13	D12	VOP_D13			I	12	down	I	
GPIO2_B6/VOP_D14	C12	VOP_D14			I	12	down	I	
GPIO2_B7/VOP_D15	B12	VOP_D15			I	12	down	I	
GPIO2_C0/VOP_D16/XIPS FCCSN	B11	VOP_D16			I	12	down	I	
GPIO2_C1/VOP_D17/XIPS FCMISO	A11	VOP_D17			I	12	down	I	
GPIO2_C2/VOP_D18/XIPS FCMOSI	C10	VOP_D18			I	12	down	I	
GPIO2_C3/VOP_D19/RISC VJTAGTDO	B10	VOP_D19			I	12	down	I	
GPIO2_C4/VOP_D20/RISC VJTAGTDI	A10	VOP_D20			I	12	down	I	
GPIO2_C5/VOP_D21/RISC VJTAGCTMS	D9	VOP_D21			I	12	down	I	
GPIO2_C6/VOP_D22/RISC VJTAGTCK	C9	VOP_D22			I	12	down	I	
GPIO2_C7/VOP_D23/RISC VJTAGRSTN	C8	VOP_D23			I	12	down	I	
VOP_DCLK	A9	VOP_DCLK			I	16	down	I	
GPIO3_A0/VOP_DEN	B9	VOP_DEN			I	12	down	I	
GPIO3_A1/VOP_HSYNC	A8	VOP_HSYNC			I	12	down	I	
GPIO3_A3/VOP_VSYNC	B8	VOP_VSYNC			I	12	down	I	
GPIO3_B1/GVI_HPD	A7	GVI_HPD			C	4	up	I	
GPIO3_B2/GVI_LOCK	B7	GVI_LOCK			C	4	up	I	
HDMIRX_EXTR	G9				A	NA	NA	NA	HDMI
HDMIRX_CLKN	L11				A	NA	NA	NA	
HDMIRX_CLKP	L12				A	NA	NA	NA	
HDMIRX_D0N	K11				A	NA	NA	NA	
HDMIRX_D0P	K12				A	NA	NA	NA	
HDMIRX_D1N	J11				A	NA	NA	NA	
HDMIRX_D1P	J12				A	NA	NA	NA	
HDMIRX_D2N	H11				A	NA	NA	NA	
HDMIRX_D2P	H12				A	NA	NA	NA	
HDMITX_CLKN	L4				A	NA	NA	NA	HDMITX
HDMITX_CLKP	M4				A	NA	NA	NA	
HDMITX_D0N	L5				A	NA	NA	NA	
HDMITX_D0P	M5				A	NA	NA	NA	
HDMITX_D1N	L6				A	NA	NA	NA	
HDMITX_D1P	M6				A	NA	NA	NA	
HDMITX_D2N	L7				A	NA	NA	NA	
HDMITX_D2P	M7				A	NA	NA	NA	
HDMITX_EXTR	M3				A	NA	NA	NA	
GVI/LVDS/MIPI_REXT	B1				A	NA	NA	NA	GVI/LVDS/MIPI_TX
GVI/LVDS/MIPI_TX0N	G1				A	NA	NA	NA	
GVI/LVDS/MIPI_TX0P	G2				A	NA	NA	NA	
GVI/LVDS/MIPI_TX1N	F1				A	NA	NA	NA	
GVI/LVDS/MIPI_TX1P	F2				A	NA	NA	NA	
GVI/LVDS/MIPI_TX2N	E1				A	NA	NA	NA	
GVI/LVDS/MIPI_TX2P	E2				A	NA	NA	NA	
GVI/LVDS/MIPI_TX3N	D1				A	NA	NA	NA	
GVI/LVDS/MIPI_TX3P	D2				A	NA	NA	NA	
GVI/LVDS/MIPI_TX4N	C1				A	NA	NA	NA	
GVI/LVDS/MIPI_TX4P	C2				A	NA	NA	NA	
GVI/LVDS/MIPI_TX5N	B2				A	NA	NA	NA	
GVI/LVDS/MIPI_TX5P	A2				A	NA	NA	NA	
GVI/LVDS/MIPI_TX6N	B3				A	NA	NA	NA	
GVI/LVDS/MIPI_TX6P	A3				A	NA	NA	NA	
GVI/LVDS/MIPI_TX7N	B4				A	NA	NA	NA	

Pad#	Ball#	func1	func2	func3	Pad Type <sup>①</sup>	Drive Strength <sup>②</sup>	Pull	Reset State <sup>③</sup>	Power Supply
GVI/LVDS/MIPI_TX7P	A4				A	NA	NA	NA	
GVI/LVDS/MIPI_TX8N	B5				A	NA	NA	NA	
GVI/LVDS/MIPI_TX8P	A5				A	NA	NA	NA	
GVI/LVDS/MIPI_TX9N	B6				A	NA	NA	NA	
GVI/LVDS/MIPI_TX9P	A6				A	NA	NA	NA	

Notes:

①: Pad types: I = input, O = output, I/O = input/output (bidirectional)

AP = Analog Power, AG = Analog Ground

DP = Digital Power, DG = Digital Ground

A = Analog

②: Output Drive Unit is mA, only Digital IO has drive value;

③: Reset state: I = input without any pull resistor, O = output without any pull resistor;

## 2.10 IO Pin Name Description

This sub-chapter will focus on the detailed function description of every pins based on different interface.

Table 2-4 RK628E IO Function Description List

Interface	Pin Name	Direction	Description
MISC	XIN_OSC	I	Clock input of 24/27MHz crystal
	XOUT_OSC	O	Clock output of 24/27MHz crystal
	NPOR	I	Chip hardware reset

Interface	Pin Name	Direction	Description
GVI/LVDS/MIPI_TX	GVI/LVDS/MIPI_REXT	I	
	GVI/LVDS/MIPI_TXiN(i=0~9)	O	GVI/LVDS/MIPI Tx negative differential line driver data output
	GVI/LVDS/MIPI_TXiP(i=0~9)	O	GVI/LVDS/MIPI Tx positive differential line driver data output

Interface	Pin Name	Direction	Description
HDMI_RX	HDMIRX_EXTR	I	USIC DATA signal
	HDMIRX_CLKN	I	HDMI clk lane N
	HDMIRX_CLKP	I	HDMI clk lane P
	HDMIRX_D0N	I	HDMI data lane 0
	HDMIRX_D0P	I	HDMI data lane 0
	HDMIRX_D1N	I	HDMI data lane 1
	HDMIRX_D1P	I	HDMI data lane 1
	HDMIRX_D2N	I	HDMI data lane 2
	HDMIRX_D2P	I	HDMI data lane 2

Interface	Pin Name	Direction	Description
HDMI_TX	HDMITX_CLKN	O	HDMI negative TMDS differential line driver clock output.
	HDMITX_CLKP	O	HDMI positive TMDS differential line driver clock output.
	HDMITX_DiN(i=0~2)	O	HDMI negative TMDS differential line driver data output.

Interface	Pin Name	Direction	Description
	HDMITX_DiP(i=0~2)	O	HDMI positive TMDS differential line driver data output.
	HDMITX_EXTR	I	HDMI reference resistor

Interface	Pin Name	Direction	Description
VOP	VOP_DCLK	O	Parallel interface clock
	GPIO3_A0/VOP_DEN	O	Parallel interface data enable
	GPIO3_A1/VOP_HSYNC	O	Parallel interface HSYNC signal
	GPIO3_A3/VOP_VSYNC	O	Parallel interface VSYNC signal
	GPIO2_A0/VOP_D0 ~ GPIO2_B7/VOP_D15	O	Parallel interface data0~data15
	GPIO2_C0/VOP_D16/XIPSFCCSN ~ GPIO2_C7/VOP_D23/RISCVJTAGRTSN	O	Parallel interface data16~data23

Interface	Pin Name	Direction	Description
JTAG	GPIO2_C3/VOP_D19/RISCVJTAGTDO	O	JTAG TDO signal
	GPIO2_C4/VOP_D20/RISCVJTAGTDI	I	JTAG TDI signal
	GPIO2_C5/VOP_D21/RISCVJTAGTMS	I	JTAG TMS signal
	GPIO2_C6/VOP_D22/RISCVJTAGTCK	I	JTAG TCK signal
	GPIO2_C7/VOP_D23/RISCVJTAGRTSN	I	JTAG RTSN signal

Interface	Pin Name	Direction	Description
SFC	GPIO1_A1/SFC_CSLK	O	SFC clock
	GPIO2_C0/VOP_D16/XIPSFCCSN	O	SFC chip select
	GPIO2_C1/VOP_D17/XIPSFCMISO	I/O	SFC data master in slave out
	GPIO2_C2/VOP_D18/XIPSFCMOSI	I/O	SFC data master out slave in

Interface	Pin Name	Direction	Description
UART	GPIO0_A4/I2S_D0_M0/UARTRX	O	UART tx signal
	GPIO0_A5/I2S_D1_M0/UARTRX	I	UART rx signal
	GPIO0_A6/I2S_D2_M0/UARTCTSN	I	UART cstn signal
	GPIO0_A7/I2S_D3_M0/UARTTRTSN	O	UART rtsn signal

## 2.11 RK628E IO Type

The following list shows IO type except Analog IO and all of Power/Ground IO.

Table 2-5 RK628E IO Type List

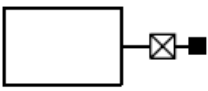
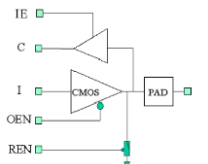
Type	Diagram	Description	Pin Name
A		Analog IO Cell with IO Voltage	EFUSE
B		3-state output pad with enable controlled input and enable controlled pull-down	GPIO0_A3/I2S_LRCK_M0

Type	Diagram	Description	Pin Name
C		3-state output pad with enable controlled Schmitt trigger input and pull-down	GPIO0_A2/I2S_SCK_M0
D		3-state output pad with enable controlled input and enable controlled pull-up	GPIO3_B1/GVI_HPD
E		3-state bi-direction I/O pads with controlled driving strength of low level, slew rate and uncontrolled pull-down resistor	GPIO0_B0/HDMITX_HPD
F		3-state bi-direction I/O pads with controlled driving strength of low level, slew rate and uncontrolled pull-up resistor	GPIO0_B1/HDMITX_SDA
G		3-state bi-direction I/O pads with controlled driving strength of low level, slew rate and uncontrolled Schmitt trigger, pull-up resistor	GPIO1_B0/HDMIRX_HPD_M0
H		CRYSTAL OSCILLATOR WITH INTERNAL RESISTOR	OSC_IN OSC_OUT
I		3-state bi-direction I/O pads with programmable drive-strength, controlled input enable, Schmitt trigger and pull-up / pull-down resistor	GPIO2_A0/VOP_D0

## Chapter 3 Electrical Specification

### 3.1 Absolute Maximum Ratings

Table 3-1 RK628E Absolute Maximum Ratings

Parameters	Related Power Group	Max	Unit
DC supply voltage for internal digital logic@1.1v	DVDD_1,DVDD_2	1.32	V
DC supply voltage for digital GPIO@1.8V mode	VCCIO2_1 VCCIO2_2	1.98 1.98	V
DC supply voltage for digital GPIO@3.3V mode	VCCIO1 VCCIO2_1 VCCIO2_2	3.63 3.63 3.63	V
DC supply voltage for HDMI RX	HDMIRX_AVDD_3V3 HDMIRX_DVDD_1V1	3.63 1.32	V
DC supply voltage for GVI/LVDS/MIPI TX	GVI/LVDS/MIPI_PLL_AVDD_3V3 GVI/LVDS/MIPI_AVDD_3V3 GVI/LVDS/MIPI_AVDD_1V1	3.63 3.63 1.32	V
DC supply voltage for HDMI TX	HDMITX_DVDD_1V1 HDMITX_AVDD_3V3	1.32 3.63	V
DC supply voltage for PLL	PLL_AVDD_1V1 PLL_AVDD_3V3	1.32 3.63	V
Storage Temperature	Tstg	125	°C
Max Conjunction Temperature	Tj	125	°C

Absolute maximum ratings specify the values beyond which the device may be damaged permanently. Long-term exposure to absolute maximum ratings conditions may affect device reliability.

### 3.2 Recommended Operating Condition

The following table describes the recommended operating condition.

Table 3-2 RK628E Recommended Operating Condition

Parameters	Symbol	Min	Typ	Max	Unit
DC supply voltage for internal digital logic@1.1v	DVDD_1,DVDD_2	0.99	1.1	1.21	V
DC supply voltage for digital GPIO@1.8V mode	VCCIO2_1 VCCIO2_2	1.71 1.71	1.8 1.8	1.89 1.89	V
DC supply voltage for digital GPIO@3.3V mode	VCCIO1 VCCIO2_1 VCCIO2_2	3.135 3.135 3.135	3.3 3.3 3.3	3.465 3.465 3.465	V
DC supply voltage for HDMI RX	HDMIRX_AVDD_3V3 HDMIRX_DVDD_1V1	3.135 0.99	3.3 1.1	3.465 1.21	V
DC supply voltage for GVI/LVDS/MIPI TX	GVI/LVDS/MIPI_PLL_AVDD_3V3 GVI/LVDS/MIPI_AVDD_3V3 GVI/LVDS/MIPI_AVDD_1V1	3.135 3.135 0.99	3.3 3.3 1.1	3.465 3.465 1.21	V
DC supply voltage for HDMI TX	HDMITX_AVDD_3V3 HDMITX_DVDD_1V1	3.135 0.99	3.3 1.1	3.465 1.21	V
DC supply voltage for PLL	PLL_AVDD_3V3 PLL_AVDD_1V1	3.135 0.99	3.3 1.1	3.465 1.21	V
PLL input clock frequency		N/A	24	N/A	MHz
Operating Temperature		-20	25	80	°C

### 3.3 DC Characteristics

Table 3-3 RK628E DC Characteristics

Parameters	Symbol	Min	Typ	Max	Units	
Digital GPIO @3.3V for GPIO0/1/2/3	Input Low Voltage	Vil	-0.3	NA	0.8	V
	Input High Voltage	Vih	2.0	NA	3.465	V
	Output Low Voltage	Vol	NA	NA	0.4	V
	Output High Voltage	Voh	2.4	NA	NA	V
	Threshold Point	Vtr+	1	1.16	1.34	V

Parameters		Symbol	Min	Typ	Max	Units
		Vtr-	1.02	1.19	1.39	V
	Pullup Resistor	Rpu	26	46	71	Kohm
	Pulldown Resistor	Rpd	27	48	102	Kohm
Digital GPIO @1.8V for GPIO0/1/2/3	Input Low Voltage	Vil	-0.3	NA	0.58	V
	Input High Voltage	Vih	1.27	NA	3.15	V
	Output Low Voltage	Vol	NA	NA	0.45	V
	Output High Voltage	Voh	1.40	NA	NA	V
	Threshold Point	Vtr+	0.9	0.95	1.01	V
		Vtr-	0.91	0.97	1.03	V
	Pullup Resistor	Rpu	33	58	88	Kohm
Pulldown Resistor	Rpd	34	60	93	Kohm	

### 3.4 Recommended Operating Frequency

Table 3-4 RK628E Recommended Operating Frequency

Parameter	Condition	Symbol	Min	Typ	Max	Unit
CPLL	0.9V , 25 °C	cppll				MHz
	0.99V , -40 °C					
	0.81V , 125 °C				1600	
GPLL	0.9V , 25 °C	gppll				MHz
	0.99V , -40 °C					
	0.81V , 125 °C				1600	
HDMI RX CTRL	0.9V , 25 °C	dclk_rx				MHz
	0.99V , -40 °C					
	0.81V , 125 °C				375	
Process	0.9V , 25 °C	Sclk				MHz
	0.99V , -40 °C					
	0.81V , 125 °C				600	