

Rockchip

RK837D

Datasheet

Revision History

Date	Revision	Description
2022-04-07	1.0	Initial release

Table of Content

Table of Content.....	2
Warranty Disclaimer	3
Chapter 1 Introduction	4
1.1 General Description.....	4
1.2 Features.....	4
1.3 Applications	5
Chapter 2 Pin Configuration and Functions	6
2.1 Pin Assignment.....	6
2.2 Pinout Number Order.....	6
Chapter 3 Electrical Characteristics.....	8
3.1 Absolute Maximum Ratings.....	8
3.2 Recommended Operating Conditions.....	8
3.3 DC Characteristics.....	8
Chapter 4 Package information	12
4.1 Ordering Information.....	12
4.2 Top Marking.....	12
4.3 Dimension	12

Warranty Disclaimer

Rockchip Electronics Co., Ltd makes no warranty, representation or guarantee (expressed, implied, statutory, or otherwise) by or with respect to anything in this document, and shall not be liable for any implied warranties of non-infringement, merchantability or fitness for a particular purpose or for any indirect, special or consequential damages.

Information furnished is believed to be accurate and reliable. However, Rockchip Electronics Co., Ltd assumes no responsibility for the consequences of use of such information or for any infringement of patents or other rights of third parties that may result from its use.

Rockchip Electronics Co., Ltd's products are not designed, intended, or authorized for using as components in systems intended for surgical implant into the body, or other applications intended to support or sustain life, or for any other application in which the failure of the Rockchip Electronics Co., Ltd's product could create a situation where personal injury or death may occur, should buyer purchase or use Rockchip Electronics Co., Ltd's products for any such unintended or unauthorized application, buyers shall indemnify and hold Rockchip Electronics Co., Ltd and its officers, employees, subsidiaries, affiliates, and distributors harmless against all claims, costs, damages, expenses, and reasonable attorney fees arising out of, either directly or indirectly, any claim of personal injury or death that may be associated with such unintended or unauthorized use, even if such claim alleges that Rockchip Electronics Co., Ltd was negligent regarding the design or manufacture of the part.

Copyright and Patent Right

Information in this document is provided solely to enable system and software implementers to use Rockchip Electronics Co., Ltd 's products. There are no expressed or implied copyright licenses granted hereunder to design or fabricate any integrated circuits or integrated circuits based on the information in this document.

Rockchip Electronics Co., Ltd does not convey any license under its patent rights nor the rights of others.

All copyright and patent rights referenced in this document belong to their respective owners and shall be subject to corresponding copyright and patent licensing requirements.

Trademarks

Rockchip and Rockchip™ logo and the name of Rockchip Electronics Co., Ltd's products are trademarks of Rockchip Electronics Co., Ltd. and are exclusively owned by Rockchip Electronics Co., Ltd. References to other companies and their products use trademarks owned by the respective companies and are for reference purpose only.

Confidentiality

The information contained herein (including any attachments) is confidential. The recipient hereby acknowledges the confidentiality of this document, and except for the specific purpose, this document shall not be disclosed to any third party.

Reverse engineering or disassembly is prohibited.

ROCKCHIP ELECTRONICS CO., LTD. RESERVES THE RIGHT TO MAKE CHANGES IN ITS PRODUCTS OR PRODUCT SPECIFICATIONS WITH THE INTENT TO IMPROVE FUNCTION OR DESIGN AT ANY TIME AND WITHOUT NOTICE AND IS NOT REQUIRED TO UNDATE THIS DOCUMENTATION TO REFLECT SUCH CHANGES.

Copyright © 2022 Rockchip Electronics Co., Ltd.

All rights reserved. No part of this publication may be reproduced, stored in a retrieval system, or transmitted in any form or by any means, electric or mechanical, by photocopying, recording, or otherwise, without the prior written consent of Rockchip Electronics Co., Ltd.

Chapter 1 Introduction

1.1 General Description

The RK837D is an USB PD3.0 Type C controller for adapter that Supports one USB Type-C port and one Type-A port.

It integrates a Cortex-M0, Flash and RAM to handle PD protocol, policy engine and device policy manager. It's built in BMC for USB PD communication.

The secondary side CC and CV loop regulation amplifiers are built in to replace TL431. The high gain and high accuracy of current sense amplifier reduce power loss in sense resistor. A 10-bits DAC adjust the CC and a 11-bits DAC adjust CV.

The RK837D also integrates PD3.0 protocol adapter. The M0 core, 56K Byte Flash space, 2K Byte RAM to achieve PD3.0 or other protocol. The Type C PHY and BMC PHY also is integrated in RK837D.

With high accuracy ADC, which not only can constantly monitor the voltage, the current, the temperature and other system parameters, but also can communicate with the cell phone by PD3.0 protocol for various needs.

All GPIOs can configured as ADC input or edge triggering interrupt. The DP/DM pins can be configured as UART mode and BC1.2 mode. It supports I2C interface.

The RK837D integrates an output switch N-MOSFET driver. VCC and VBUS discharge function is integrated for PD requirement.

1.2 Features

The features listed below which may or may not be present in actual product, may be subject to the third party licensing requirements. Please contact Rockchip for actual product feature configurations and licensing requirements.

- Protocol Handler
 - Supports one USB Type-C port and one Type-A port
 - Supports USB PD 3.0, Type C PHY and protocol, PD TID number is 5141
 - Supports QC4+ protocol, Report number is QC20210303222
 - Integrates BMC Transceiver and PHY
 - Other proprietary protocol support by MCU
 - Integrates Cortex-M0, 56K Byte program space, and 2K Byte RAM
 - DP/DM pins can be configured as UART mode, BC1.2 mode and GPIO mode
 - DP2/DM2 pins can configured as BC1.2 mode and GPIO mode
- CCCV Controller
 - 3~22V, 10mV/step (11bits) CV output
 - 0.1A~12A, step 12mA (5mohm Rsense)
- High accuracy ADC
 - Integrates 10 channels voltage ADC
 - 2 channel current ADC
- Other Function and Protection
 - Integrates a N-MOSFET driver for output control
 - Integrates a quickly discharge N-MOSFET
 - Integrates a VBUS discharge circuit

- Integrates a low power RC oscillator, 3 Timer, and a WDT
- Protection: OCP, OVP, UVP, OTP
- QFN-24 4x4mm Package

1.3 Applications

- USB PD type-C Power Adaptor for Smart-Phone, Tablet, and Notebook, etc.

RK837D Typical Application Circuit

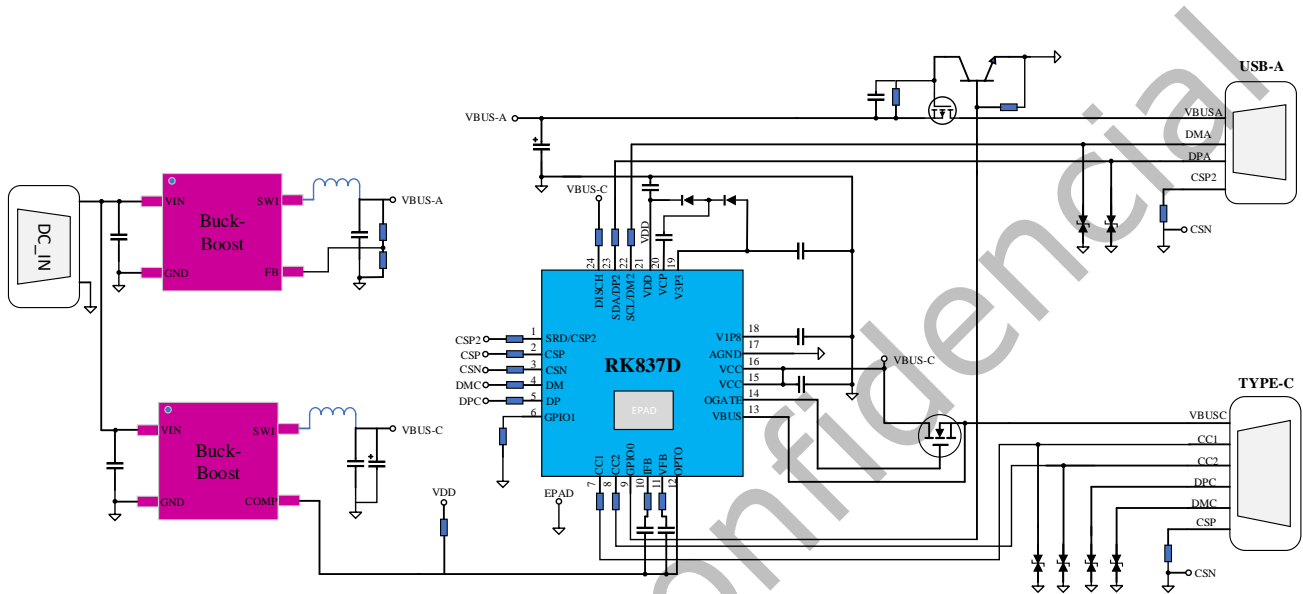

Fig. 1-1 1A+1C

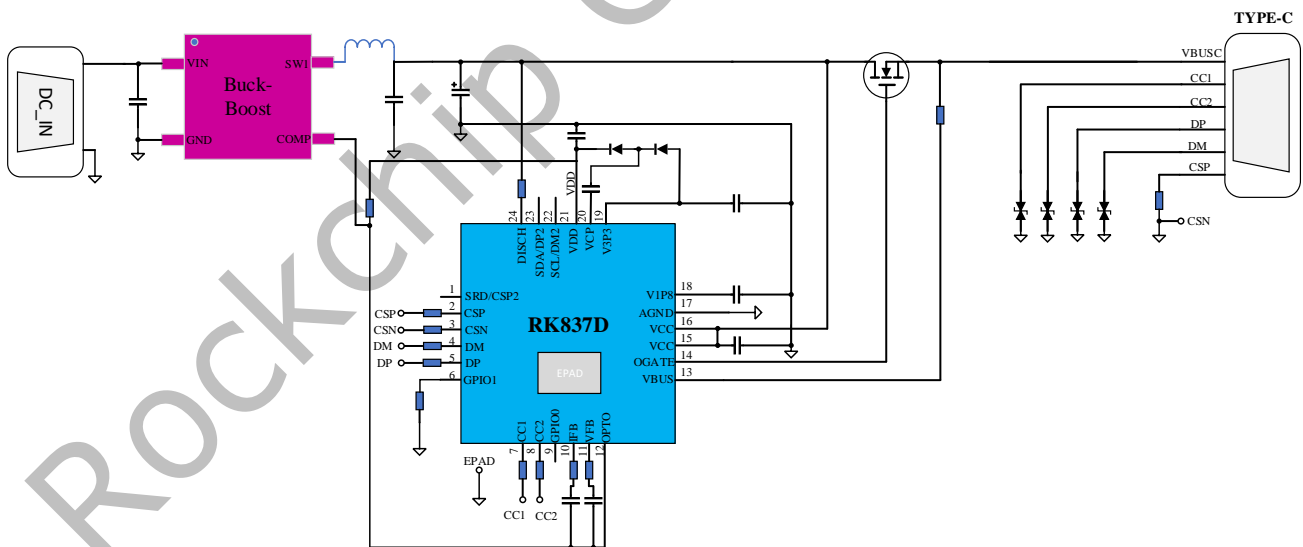

Fig. 1-2 1C

Chapter 2 Pin Configuration and Functions

2.1 Pin Assignment

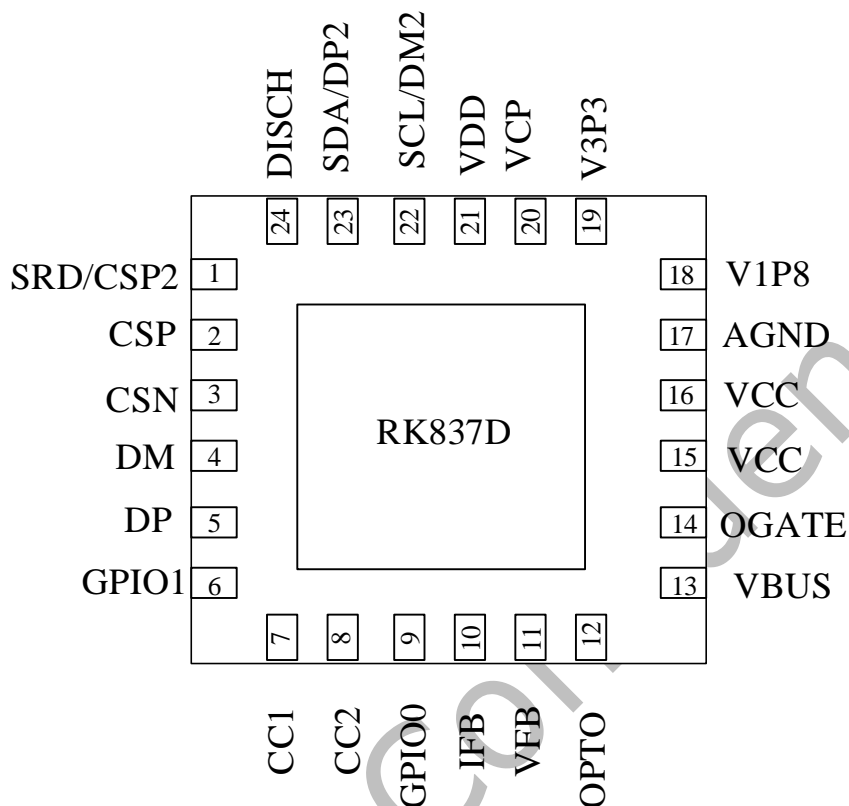

Fig. 2-1 Pin Assignment

2.2 Pinout Number Order

Pin No.	Pin Name	Pin Description
1	SRD/CSP2	High side or low side SR Drain detect for line voltage detect Output current sense positive point 2
2	CSP/AN6/GPIO6	Output current sense positive point 1 ADC channel 6 GPIO6
3	CSN/AN7/GPIO7	Output current sense negative point ADC channel 7 GPIO7
4	DM/RX/AN5/GPIO5	USB DM terminal UART RX terminal ADC channel 5 GPIO5
5	DP/TX/AN4/GPIO4	USB DP terminal UART TX terminal ADC channel 4 GPIO4
6	AN1/GPIO1/RT1	ADC channel 1, connect it to a NTC for temperature sense

Pin No.	Pin Name	Pin Description
		GPIO1
7	CC1	USB CC1 terminal
8	CC2	USB CC2 terminal
9	AN0/GPIO0/RT0	ADC channel 0, connect it to a NTC for temperature sense GPIO0
10	IFB	Constant current mode feedback
11	VFB	Constant voltage mode feedback
12	OPTO	Secondary side feedback opto-coupler driver
13	VBUS	VBUS discharge input VBUS ADC input
14	OGATE	The driver of Power-path NFET.
15	VCC	The feedback loop input for voltage sense VCC ADC input
16	VCC	Power supply for this chip
17	AGND	Analog GND
18	V1P8	1.8V bias power supply for internal circuit
19	V3P3	3.3V bias power supply for internal circuit
20	VCP	Charge pump capacitor
21	VDD	5V bias power supply for internal circuit
22	SCL/DM2/AN2/GPIO2	I2C SCL USB DM terminal for another USB port ADC channel 2. GPIO2.
23	SDA/DP2/AN3/GPIO3	I2C SDA USB DP terminal for another USB port ADC channel 3 GPIO3
24	DISCH	Discharge input for VCC
EPAD	DGND	Digital ground

Chapter 3 Electrical Characteristics

3.1 Absolute Maximum Ratings

Parameters	Min	Max	Units
Max range on pins VCC, VBUS, OPTO, DISCH, DP, DM, CC1, CC2	-0.3	26	V
Max range on pins OGATE	-0.3	32	V
Max range on pin CSP, CSN, VDD, SRD, VCP, VFB, IFB	-0.3	6	V
Max range on pin GPIO0~GPIO3, V3P3	-0.3	3.6	V
Max range on pins V1P8	-0.3	2.2	V
Storage temperature range, T _s	-60	150	°C
Operating temperature range, T _j	-40	85	°C
Maximum Soldering Temperature, T _{SOLDER}		260	°C
ESD HBM	2		kV
ESD CDM	1		kV

Note 1. Exposure to the conditions exceeded absolute maximum ratings may cause the permanent damages and affect the reliability and safety of both device and systems using the device. The functional operations cannot be guaranteed beyond specified values in the recommended conditions.

3.2 Recommended Operating Conditions

Parameters	Min	TYP	Max	Unit
Voltage range on pins VCC, VBUS, OPTO, DISCH, DP,DM,CC1,CC2			22	V
Voltage range on pin SRD, VFB, IFB			5.5	V
Voltage range on pins CSP, CSN			1.8	V
Voltage range on GPIO0~GPIO3		3.3		V
Power Dissipation			0.4	W
Ambient Temperature Range	-40		85	°C
Junction Temperature Range	-40		125	°C

3.3 DC Characteristics

T_A=25°C; unless otherwise specified.

Parameters	Symbol	Condition	Min	Typ	Max	Unit
Secondary Side VCC, DISCH, VBUS Section						
VCC turn on threshold	V _{CC_ON}	VCC rising		3		V
VCC UVLO threshold	V _{OUT_UV}	Four UVLO levels selected by register	2.7	2.8	2.9	V
DISCH Section						
Pull low impedance	R _{DISCH}	For DISCH pin		10	15	Ω
Maximum sinking current	I _{DISCH_MS}	For DISCH pin	0.2		0.7	A
VBUS pull low impedance	R _{VBUS}	For VBUS pin		1000		Ω
Secondary Side VDD, V1P8, V3P3 Section						

Parameters	Symbol	Condition	Min	Typ	Max	Unit
VDD voltage range	V _{VDD_RANGE}			5		V
VDD charge pump frequency	F _{CP}			500		KHz
V3P3 voltage	V _{3p3}			3.3		V
V1p8 voltage	V _{1p8}			1.8		V
Secondary Side OGATE Section						
OGATE drive N-MOSFET high level	V _{OGH}	Capacitor load only for OGATE	VCC+5	VCC+2*VDD		V
OGATE drive N-MOSFET low level	V _{OGL}		0	-	0.3	V
SRD Section						
AC voltage detect from Low side SR Drain	V _{DET_LS}	Programed code=0x0		0.8		V
		Programed code=0x7		0.1		V
		Programed code=0xF		1.6		V
AC voltage detect from High side SR Drain	V _{DET_HS}	Programed code=0x0		180		uA
		Programed code=0x7		40		uA
		Programed code=0xF		200		uA
AC voltage detect blanking time	T _{DET_BLK}	Programed code=0		400		nS
		Programed code=1		1000		nS
SRD detect internal low side divide resistor	R _{SRD}			2.4		KΩ
SRD detect low clamp voltage	V _{CLPN}	For high side detect	-100		100	mV
Secondary Side CCCV Section						
CC Range	V _{REF_CC_RANGE}	10bits,default 3A, 5mohm Rsense	0.1	3	12	A
CC Step	V _{REF_CC_STEP}	5mohm Rsense		12		mA
CV Range	V _{REF_CV_RANGE}	11bits,default 5V	3	5	22	V
CV step	V _{REF_CV_STEP}			10		mV
CV OVP threshold	V _{REF_CV_OVP}	2bits, 110%~125%, step 5%		110		%
OTP Section						
Thermal shut down threshold	T _{SD}			135		°C
Thermal shut down hysteresis			-	20	-	°C
ADC Section						
Resolution for ADC	Res _{VADC}			10		bits
VBUS/VCC sense voltage	V _{IN_RANGE}		0		24	V

Parameters	Symbol	Condition	Min	Typ	Max	Unit
VBUS Current channel		Voltage between CSP and CSN	0		50	mV
GPIO voltage Range			0.2		3.1	V
ADC Data Convert Rate	F _{IADC}			1		KHz
CC1/CC2 Section						
current source for DFP pull-up indication	I _{pullup}	default current	70	80	90	uA
		1.5A	170	180	190	uA
		3A	314	330	346	uA
Vconn power source capability	P _{Vconn}	When Vcc=5V	100			mW
Vconn discharge resistance	R _{Vconn_DIS}				6	kΩ
USB PD normative spec						
BMC bit rate	F _{Bit_Rate}		270	300	330	Kbps
Fall time	T _{Fall}	10% and 90% amplitude points; C _{LOAD} =650pF	300	350	400	nS
Rise time	T _{Rise}	10% and 90% amplitude points; C _{LOAD} =650pF	300	350	400	nS
Voltage swing	V _{Swing}	Four steps: 0.98/1.05/1.125/1.2	0.98	1.125	1.2	V
Transmitter output impedance	Z _{Driver}		33		75	Ω
DP1, DM1, DP2, DM2, spec						
Resistance of switch when DP and DM are short	R _{D_{CP}_DAT}			30		Ω
GPIO spec						
Input low voltage	VIL	3.3V level option	-0.3		1.2	V
		1.8V level option	-0.3		0.6	V
Input high voltage	VIH	3.3V level option	2.3		3.6	V
		1.8V level option	1.2		1.9	V
Pull up resistor	R _{up}			39		Kohm
Pull down resistor	R _{down}			39		Kohm
Output low voltage	VOL	3.3V level option, I _{ol} =-8mA	0		0.45	V
		1.8V level option, I _{ol} =-8mA	0		0.45	V
Output high voltage	VOH	3.3V level option, I _{ol} =8mA	V3P3-0.45		3.3	V
		1.8V level option, I _{ol} =4mA	V1P8-0.45		1.8	V

Parameters	Symbol	Condition	Min	Typ	Max	Unit
Current source for NTC temperature sense	I _{NTC}	Set current to 100uA	95	100	105	uA
		Set current to 20uA	19	20	21	uA
		Set current to 4uA	3.8	4	4.2	uA

Rockchip Confidential

Chapter 4 Package information

4.1 Ordering Information

Orderable Device	RoHS status	Package	Package Qty	Device Feature
RK837D	RoHS	QFN24L(4X4)	5000pcs by tape	Protocol MCU

4.2 Top Marking

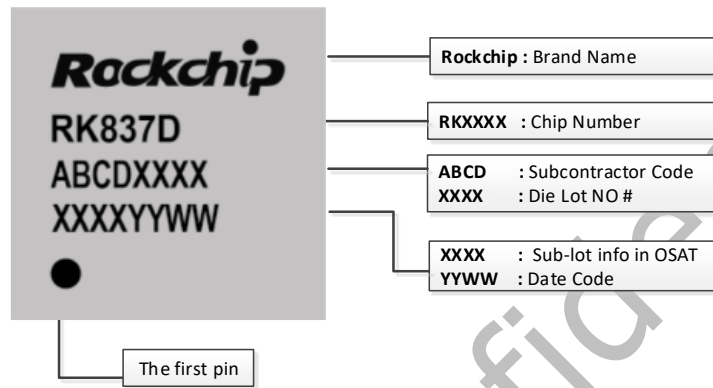

4.3 Dimension

4.3.1 SP01-Dimension

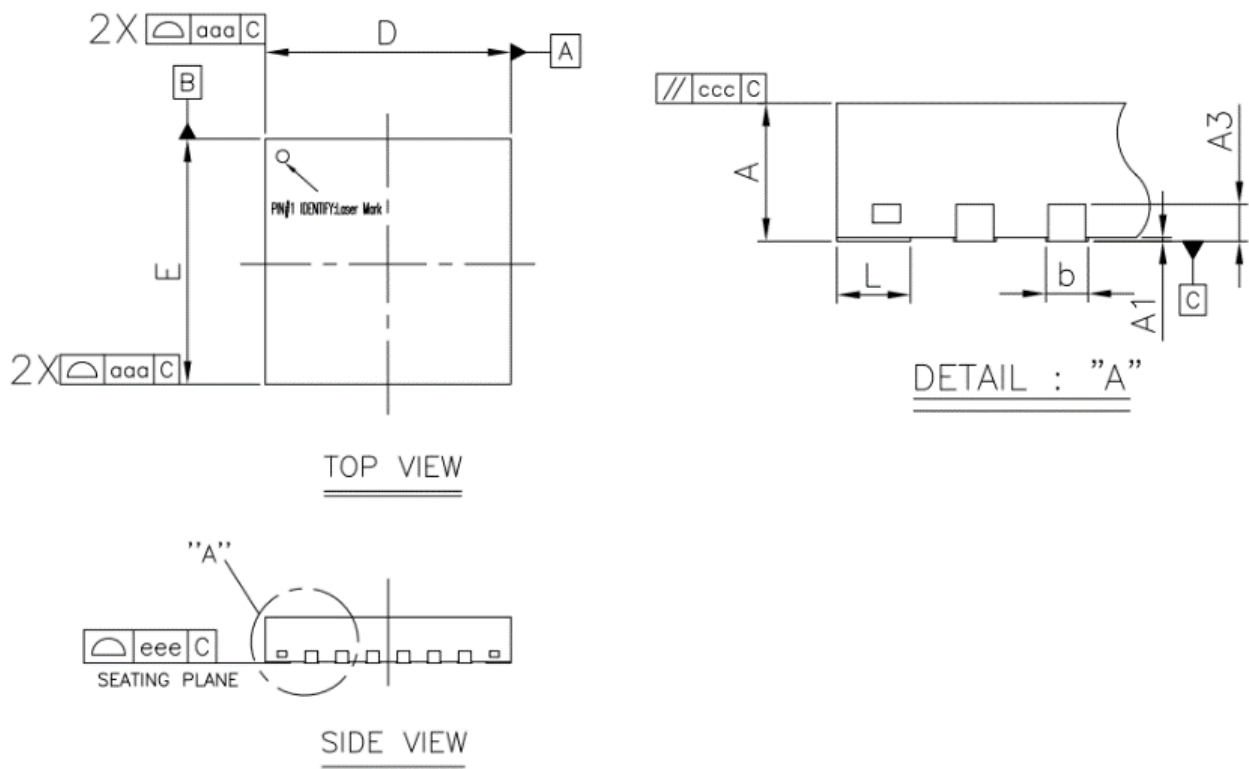

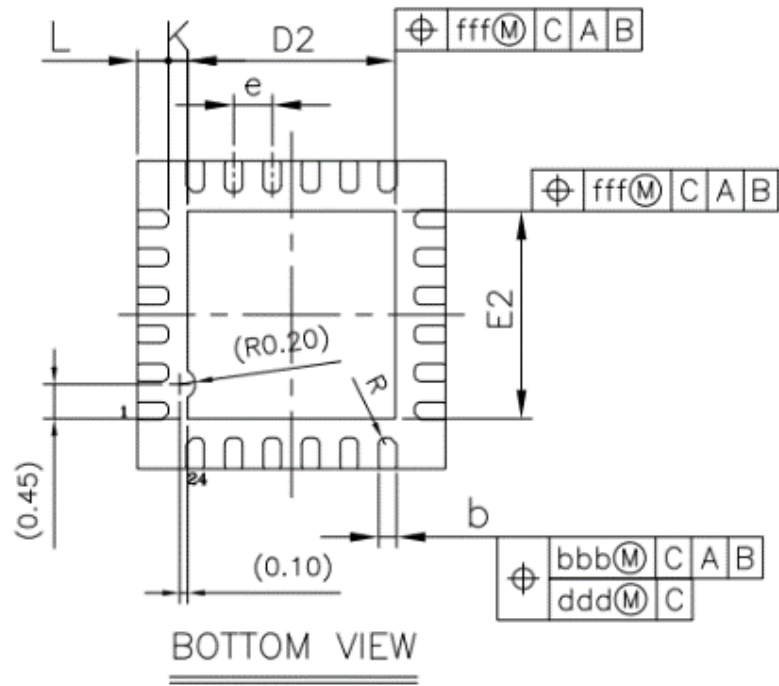

Symbol	Dimension in mm			Dimension in inch		
	MIN	NOM	MAX	MIN	NOM	MAX
A	0.70	0.75	0.80	0.028	0.030	0.031
A1	0.00	0.02	0.05	0.000	0.001	0.002
A3	0.20 REF			0.008 REF		
b	0.16	0.23	0.28	0.006	0.009	0.011
D	3.90	4.00	4.10	0.154	0.157	0.161
E	3.90	4.00	4.10	0.154	0.157	0.161
D2	2.60	2.70	2.80	0.102	0.106	0.110
E2	2.60	2.70	2.80	0.102	0.106	0.110
e	0.50 BSC			0.020 BSC		
L	0.30	0.40	0.50	0.012	0.016	0.020
K	0.20	---	---	0.008	---	---
R	0.08	---	0.13	0.003	---	0.005
aaa	0.15			0.006		
bbb	0.10			0.004		
ccc	0.10			0.004		
ddd	0.05			0.002		
eee	0.08			0.003		
fff	0.10			0.004		

2.4.2 SP02-Dimension

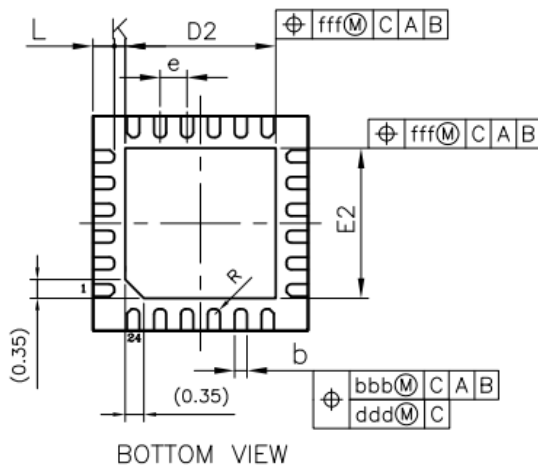
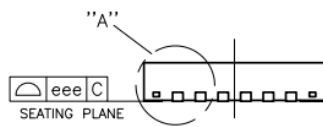
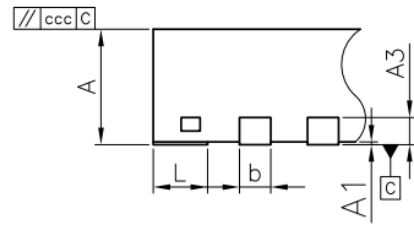
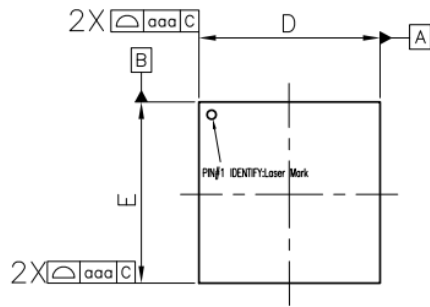

Symbol	Dimension in mm			Dimension in inch		
	MIN	NOM	MAX	MIN	NOM	MAX
A	0.80	0.85	0.90	0.031	0.033	0.035
A1	0.00	0.02	0.05	0.000	0.001	0.002
A3	0.20 REF			0.008 REF		
b	0.18	0.23	0.28	0.007	0.009	0.011
D	3.90	4.00	4.10	0.154	0.157	0.161
E	3.90	4.00	4.10	0.154	0.157	0.161
D2	2.70	2.80	2.90	0.106	0.110	0.114
E2	2.70	2.80	2.90	0.106	0.110	0.114
e	0.50 BSC			0.020BSC		
L	0.30	0.40	0.50	0.012	0.016	0.020
K	0.20	---	---	0.008	---	---
R	0.09	---	0.14	0.004	---	0.006
aaa	0.15			0.006		
bbb	0.10			0.004		
ccc	0.10			0.004		
ddd	0.05			0.002		
eee	0.08			0.003		
fff	0.10			0.004		

2.4.3 HT-Dimension

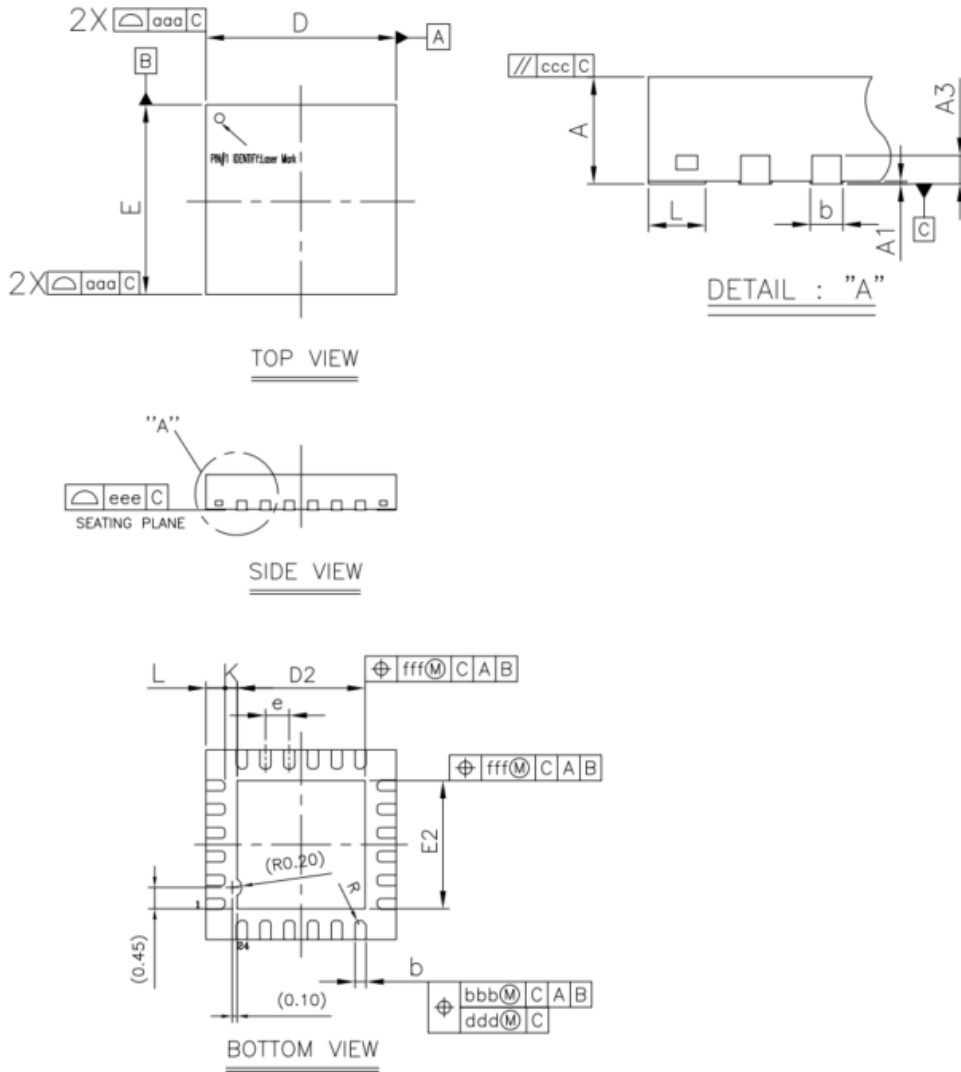

SYMBOL	MILLIMETER		
	MIN	NOM	MAX
A	0.70	0.75	0.80
A1	0	0.02	0.05
b	0.20	0.25	0.30
c	0.203REF		
D	3.90	4.00	4.10
D2	2.60	2.70	2.80
e	0.50BSC		
Nd	2.50BSC		
Ne	2.50BSC		
E	3.90	4.00	4.10
E2	2.60	2.70	2.80
L	0.35	0.40	0.45
h	0.25	0.30	0.35
K	0.25REF		
R	0.075REF		

2.4.5 Recommended Land Pattern

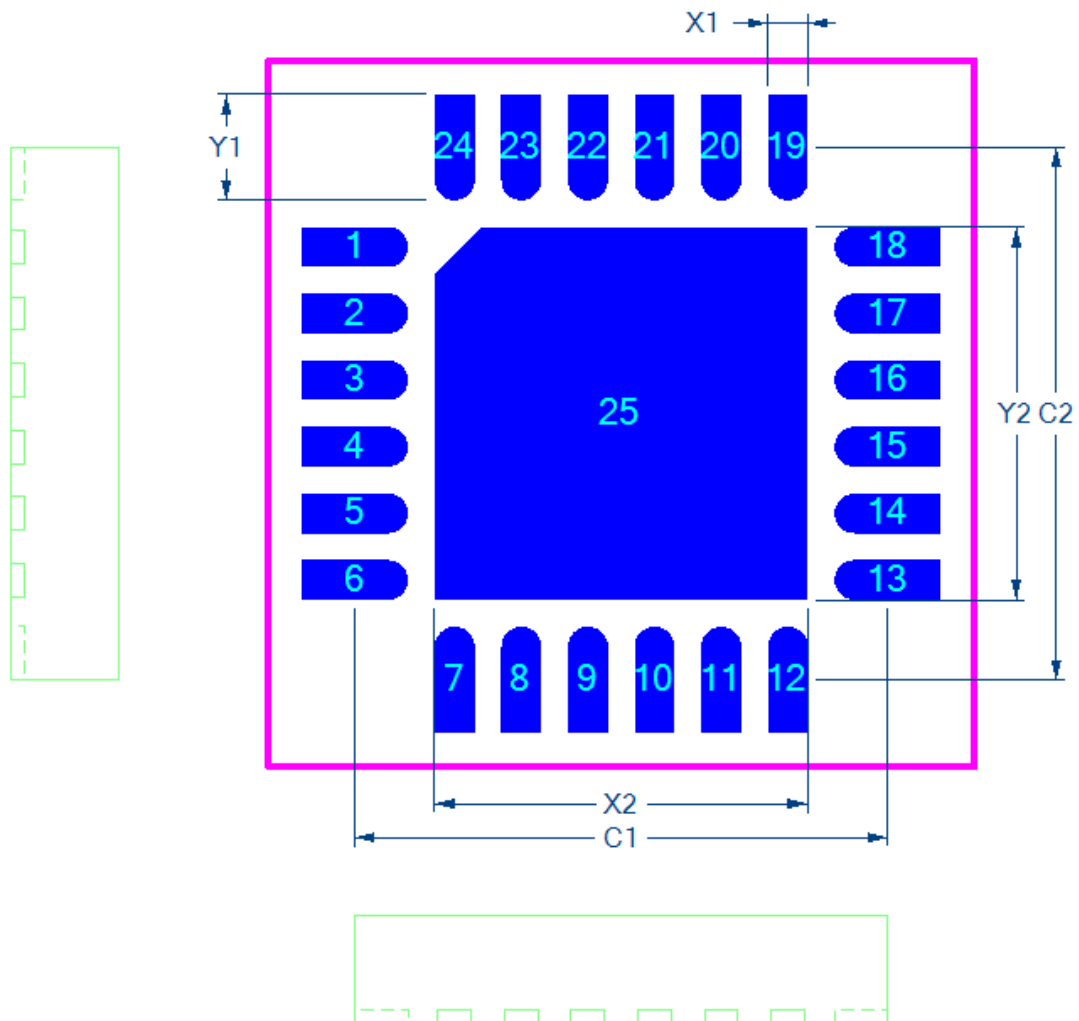

Dimensions	
Land Space C1	4.00
Land Space C2	4.00
Land X1	0.30
Land Y1	0.80
Tab Land X2	2.80
Tab Land Y2	2.80
Silkscreen R1	4.00
Silkscreen R2	4.00
Courtyard V1	5.30
Courtyard V2	5.30