

Rockchip RK860M Datasheet

Revision History

Date	Revision	Description
2023-08-03	1.1	<ol style="list-style-type: none">1. Modify description of the Pin Assignment and layout recommendation2. Modify description of Typical Application Diagrams3. Update the MSL Information and Lead Finish/Pin Material Information4. Modify description of the Absolute Maximum Ratings for LX
2022-10-19	1.0	Initial release

Warranty Disclaimer

Copyright © 2023 Rockchip Electronics Co., Ltd. All rights reserved.

No part of this document may be reproduced, transmitted or used in any form or by any means without the written prior consent of Rockchip Electronics Co., Ltd.

Trademark

Rockchip is a registered trademark of Rockchip Electronics Co., Ltd. in the People's Republic of China and other countries/areas. Other brands, product names mentioned in this document are the property of their respective owners.

Disclaimer

Rockchip Electronics Co., Ltd. ("Rockchip") may make changes to any information in this document at any time without any prior notice.

Information in this document is provided just as a reference or typical applications. All or part of product features described in this document may not be within the purchase scope or the usage scope, and may be subject to the third party licensing requirements. All statements, information in this document is provided "AS IS" without warranties of any kind, either express or implied. Actual performance of Rockchip products may vary in different applications. Third party licenses maybe required to use some features supported by Rockchip products. Customers shall be solely and exclusively responsible to obtain all appropriately required third party licenses prior to its such use. Should customers use the features supported by Rockchip products without any required third party license, customers shall indemnify and hold Rockchip and its subsidiaries, affiliates as well as distributors harmless against all claims, costs, damages, and expenses, and reasonable attorney fees arising out of any claim associated with such unauthorized use. Rockchip products are not intended for use in military, airplane, medical devices, lifesaving or life sustaining applications ("Unintended Uses"). Customers shall take any and all actions to ensure using Rockchip products in a lawful manner and shall be liable for Unintended Uses.

Table of Contents

Warranty Disclaimer.....	2
Table of Contents.....	3
Figure Index	4
Table Index.....	5
Chapter 1 Introduction	6
1.1 Overview.....	6
1.2 Feature	6
1.3 Typical Application Diagrams	6
1.4 Pin Assignment	7
1.5 Pinout Number Order	7
Chapter 2 Electrical Characteristics	9
2.1 Absolute Maximum Ratings(Note 1)	9
2.2 Recommended Operating Conditions(Note 2).....	9
2.3 Electrical Characteristics.....	9
Chapter 3 Chip Version Description	11
Chapter 4 Register Description	12
Chapter 5 Typical Performance Characteristics	15
Chapter 6 Package information	17
6.1 Ordering Information	17
6.2 Top Marking.....	17
6.3 MSL Information	17
6.4 Lead Finish/Pin Material Information	17
6.5 Dimension	18
6.6 Layout Recommendation	18
Chapter 7 Thermal Management.....	20
7.1 Overview	20
7.2 Package Thermal Characteristics.....	20

Figure Index

Fig. 1-1 RK860M Application.....	6
Fig. 1-2 RK860 Application in Particular Cases.....	7
Fig. 1-3 Pin Assignment (Top view)	7
Fig. 6-1 FCQFN16L(03x03X0.85-0.40)	18
Fig. 6-2 PCB Layout Suggestion	19

Rockchip Confidential

Table Index

Table 7-1 Thermal Resistance Characteristics	20
Table 7-2 SnPb Eutectic Process-Classification Temperatures (TC)	20
Table 7-3 Pb-Free Process-Classification Temperatures (TC)	20
Table 7-4 Classification Reflow Profiles	21

Rockchip Confidential

Chapter 1 Introduction

1.1 Overview

The RK860M is a high efficiency 2.4MHz synchronous step down DC/DC regulator IC capable of delivering up to 7A output current. It can operate over a wide input voltage range from 2.7V to 5.5V. And, it integrates a main switch and a synchronous switch with both very low $R_{DS(ON)}$ to minimize the conduction loss. The output voltage can be programmed from 0.7125V to 1.5V with 12.5mV/step or 0.5V to 1.5V with 6.25mV/step through I²C interface.

The RK860M is in a space saving, low profile FCQFN 3.0mm*3.0mm-16 package.

1.2 Feature

- Input voltage range: 2.7V-5.5V
- 2.4MHz switching frequency minimizes the external components
- Typical 70uA quiescent current when $V_{IN}=3.8V$ and $Temp=25^{\circ}C$
- Low $R_{DS(ON)}$ for internal switches(PFET/NFET):24mohm/16ohm @ $V_{IN}=3.8V$
- Programmable output voltage:0.7125V to 1.5V with 12.5mV/step or 0.5V to 1.5V with 6.25mV/step
- 7A continuous output current capability
- Capable for 0.24uH inductor and 22uF*2 ceramic capacitor
- Hic-cup mode protection for hard short condition
- Integrate inner protection: Cycle by cycle OCP and V_{IN} -OVP/UVLO/DIE-TSD
- RoHS compliant and Halogen free
- Compact package: FCQFN 3.0*3.0-16

1.3 Typical Application Diagrams

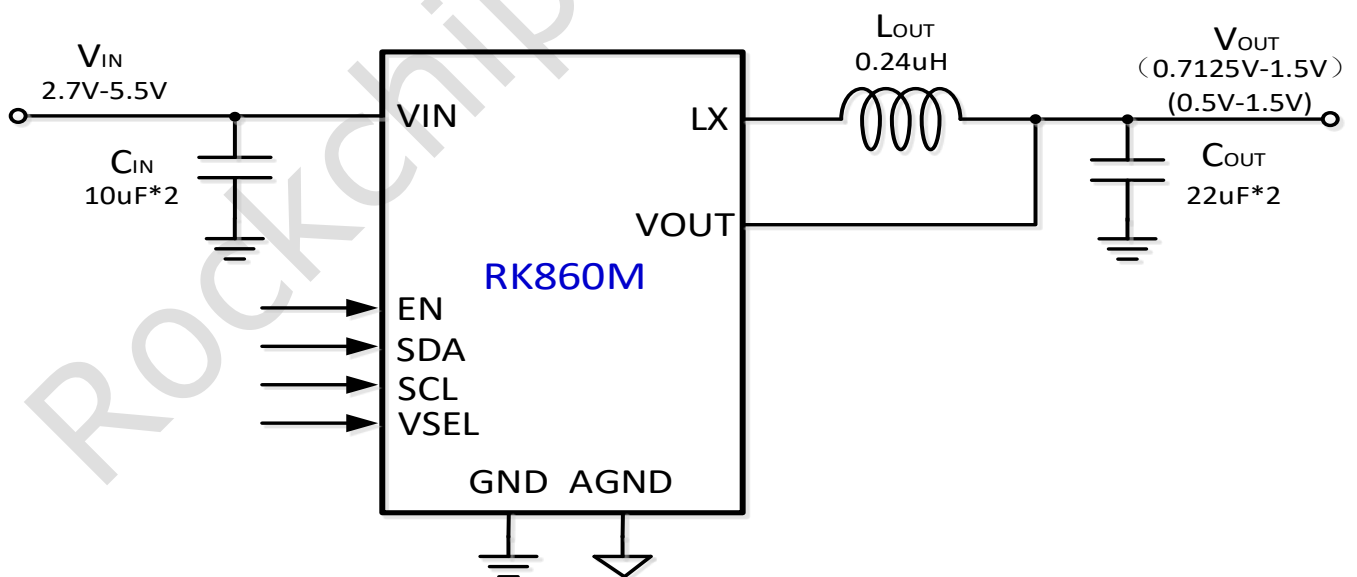

Fig. 1-1 RK860M Application

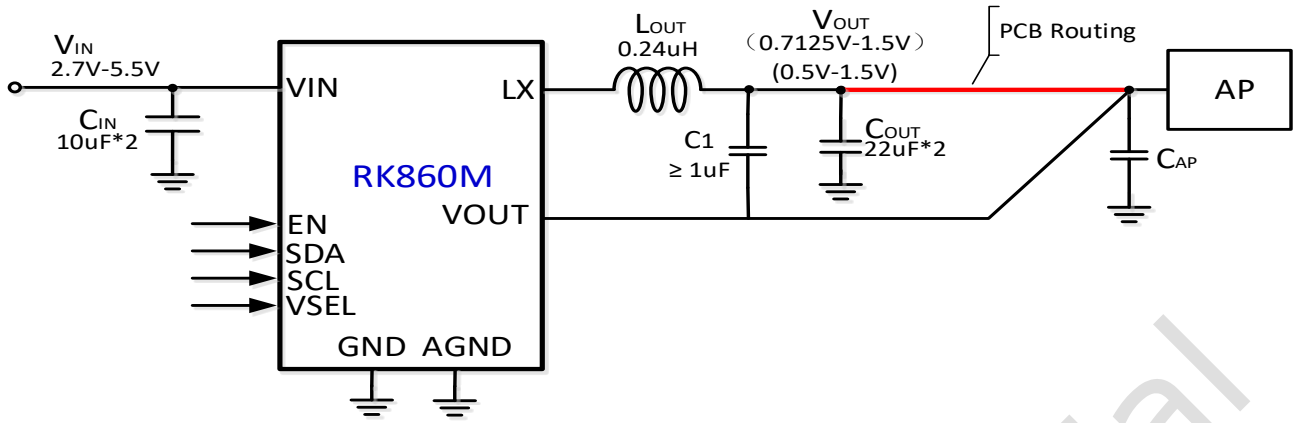

Fig. 1-2 RK860 Application in Particular Cases

1.4 Pin Assignment

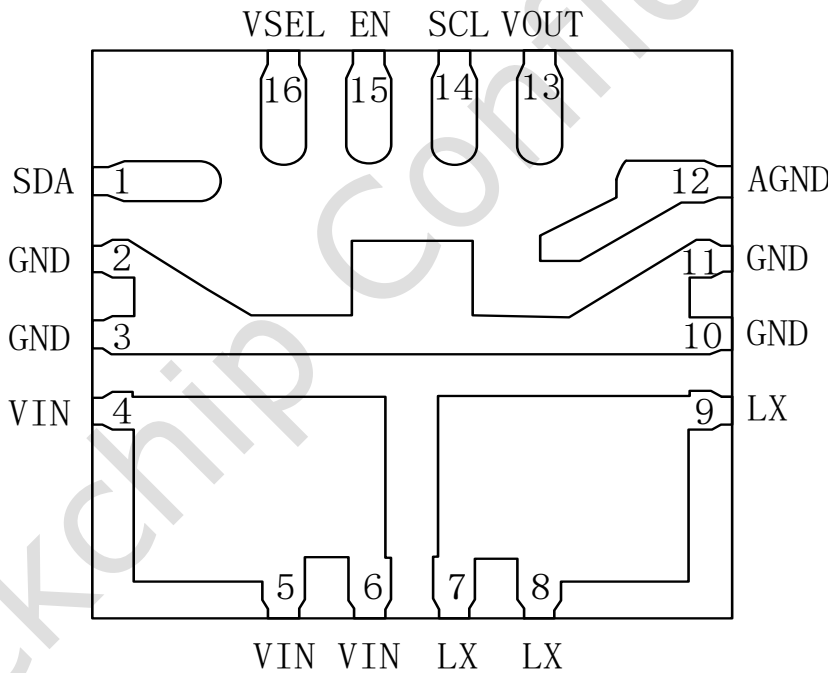

Fig. 1-3 Pin Assignment (Top view)

1.5 Pinout Number Order

Number	Name	Function	I/O
1	SDA	I2C interface Bi-directional Data line. (Open darin)	I/O
2,3,10,11	GND	Power ground pins.	Ground
4,5,6	VIN	Power input pins. These pins must be decoupled to ground by 2 10uF ceramic capacitor as input filter at least. The input capacitor should be placed as close as possible between VIN and GND pins.	Power

7,8,9	LX	Switching node pin. Connect these pins to switching node of inductor.	Output
12	AGND	Analog ground pin.	
13	VOUT	Sense pin for output. Connect to the output capacitor side	Output
14	SCL	I2C interface clock line.	Input
15	EN	Enable control pin. Active high. Do not leave it floating.	Input
16	VSEL	Voltage select pin. When this pin is low, V_{OUT} is set by the VSEL0 register. When this pin is high, V_{OUT} is set by the VSEL1 register.	Input

Chapter 2 Electrical Characteristics

Note 1: Stresses beyond the "Absolute Maximum Ratings" may cause permanent damage to the device. These are stress ratings only. Functional operation of the device at these or any other conditions beyond those indicated in the operational sections of the specification is not implied. Exposure to absolute maximum rating conditions for extended periods may affect device reliability.

Note 2: The device is not guaranteed to function outside its operating conditions.

2.1 Absolute Maximum Ratings(Note 1)

Parameter	Min	Max	Units
Voltage range on pins VIN:	-0.3	6.0	V
Voltage range on pins LX:	-0.3 (-2V for <20ns and -3.5V for <10ns)	6.6(7V for <20ns)	V
Voltage range on other pins	-0.3	VIN+0.6	V
Continuous power dissipation, PD @ TA=25°C, FCQFN		0.5	W
Junction temperature range, T _J	-40	150	°C
Lead Temperature(soldering 10 sec), T _{SOLDER}		260	°C
Storage temperature range, T _S	-65	150	°C
ESD Susceptibility			
ESD HBM		2000	V
ESD CDM		1000	V

2.2 Recommended Operating Conditions(Note 2)

Parameter	Symbol	value	Units
Supply Input Voltage	V _{IN}	2.7~5.5	V
Output Voltage	V _{OUT}	0.5~1.5	V
Inductor	L	0.22~0.47	uH
Input Capacitor	C _{IN}	>10	uF
Output Capacitor	C _{OUT}	44~88	uF
Junction temperature range	T _J	-40~125	°C
Ambient temperature range	T _a	-40~85	°C

2.3 Electrical Characteristics

(With typical application circuit shown in below, V_{IN}=3.8V, V_{OUT}=1.0V, L=0.24uH, C_{OUT}=22uF*2, T_A=25°C unless otherwise specified.)

PARAMETERS	SYMBOL	Note	MIN	TYP	MAX	UNIT
The UVLO threshold voltage of VIN	V _{IN_UVLO}	Vin rising		2.55	2.65	V
The UVLO Hysteresis voltage of VIN	V _{IN_UVLO_HYS}	Vin falling		150		mV
The OVP threshold voltage of VIN	V _{IN_OV}	Vin rising		6		V
The OVP Hysteresis voltage of VIN	V _{IN_OV_HYS}	Vin falling		200		mV
Quiescent Current	I _q	No switching, vfb=105%Vref.		70		uA

PARAMETERS	SYMBOL	Note	MIN	TYP	MAX	UNIT
Shutdown current	Isd	EN=L		0.1		uA
Software shutdown current	Isd_soft	EN=H, BUCK_EN=L		25		uA
Internal soft-start time	Tss	Vout=1.0V, from BUCK_EN rising edge to Vout>92%.		260		uS
Oscillator Frequency	Fclk	PWM mode or FPWM mode	2.2	2.4	2.6	MHz
Discharge resistance	Rdisc	EN=L/BUCK_EN=0		150		Ω
Input logic high threshold of signal (EN/VSEL)	VIH		1.1			V
	VIL				0.4	V
Input logic high threshold of signal (SDA/SCL)	VIH		1.26			V
	VIL				0.54	V
Vout Accuracy when FPWM	VREG1(The output voltage error)	Forced PWM, VOUT=1.0V	-0.6		+0.6	%
Vout Accuracy when PFM	VREG2(The output voltage error)	Auto PFM, VOUT=1.0V	-1.5		1.5	%
PMOS RDS(ON)	RDS(ON)P	VIN PIN to LX PIN, VIN=3.8V		24		mΩ
NMOS RDS(ON)	RDS(ON)N	LX PIN to GND PIN, VIN=3.8V		16		mΩ
Maximum current of PMOS	Ipeak		8.5			A
Maximum current of NMOS	Ivalley		7.0			A
Thermal shutdown temperature	TSD	Rising TSD threshold		150		°C
Thermal shutdown Hysteresis	TSD_HYS			25		°C

Chapter 3 Chip Version Description

DIE-ID	I2C-ADDR (7-bit)	Vout Range/V	Default Vout/V	STEP/ mV	DIE_ID
RK860M-0	40H	0.7125-1.5	1.0	12.5	0X8
RK860M-1	41H	0.7125-1.5	1.0	12.5	0X8
RK860M-2	42H	0.5-1.5	0.8	6.25	0XA
RK860M-3	43H	0.5-1.5	0.8	6.25	0XA

Chapter 4 Register Description

VSEL0_A

Address: (0x00)

Bit	Attr	Reset Value	Description
7	RW	0x1	BUCK_EN0: Software buck enable. 1: enable BUCK work; 0: shut off BUCK (When external EN pin is low. The regulator is off. When external EN pin is high, BUCK_EN bit takes precedent.)
6	RW	0x0	MODE0: 0=Allow auto-PFM mode during light load 1=Forced PWM mode
5:0	RW	0x17	NSEL0: 12.5mV/step (just for DIE_ID=0X8) 000000=0.7125V; 000001=0.7250V; 000010=0.7375V; 010111=1.0000V; 111111=1.5V;

VSEL1_A

Address: (0x01)

Bit	Attr	Reset Value	Description
7	RW	0x1	BUCK_EN1: Software buck enable. 1: enable BUCK-LOOP work; 0: shut off BUCK-LOOP (When external EN pin is low. The regulator is off. When external EN pin is high, BUCK_EN bit takes precedent.)
6	RW	0x0	MODE1: 0=Allow auto-PFM mode during light load 1=Forced PWM mode
5:0	RW	0x17	NSEL1: 12.5mV/step (just for DIE_ID=0X8) 000000=0.7125V; 000001=0.7250V; 000010=0.7375V; 010111=1.0000V; 111111=1.5V;

Control_Register

Address: (0x02)

Bit	Attr	Reset Value	Description
7	RW	0x1	Output Discharge: 0=discharge resistor is disabled. 1=discharge resistor is enabled.
6:4	RW	0x0	Slew Rate: Set the slew rate for positive voltage transitions. 000 = 10mV/0.15us 001 = 10mV/0.3us 010 = 10mV/0.6us 011 = 10mV/1.2us 100 = 10mV/2.4us 101 = 10mV/4.8us 110 = 10mV/9.6us 111 = 10mV/19.2us
3:0	RW	0x0	Always reads back 0. RESET: Setting to 1 resets all registers to default values.

ID1 Register

Address: (0x03)

Bit	Attr	Reset Value	Description
7:5	R	0x4	VENDOR: IC vendor Rockchip code.
4	R	0x0	Reserved: Always reads back 0.
3:0	R	0x8/0xA	DIE_ID: 0x8: Output Voltage from 0.7125V to 1.5V with 12.5mV/step 0xA: Output Voltage from 0.5V to 1.5V with 6.25mV/step

ID2 Register

Address: (0x04)

Bit	Attr	Reset Value	Description
7:4	R	0x0	Reserved: Always reads back 0.
3:0	R	NA	NA

PGOOD Register

Address: (0x05)

Bit	Attr	Reset Value	Description
7	R	0x0	PGOOD: 1: Buck is enabled and soft-start is completed. (Vout>92% normal set-value) 0: Vout is abnormal

Bit	Attr	Reset Value	Description
6	R	0x0	TSD: thermal shut down BUCK. 1: Tdie>150'C, 0: Tdie<125'C
5	R	0x0	IOVP: Over input voltage shut-off protection state. 1: VIN>6V, 0: VIN<5.8V
4	R	0x0	UVLO: Input voltage under-lock state. 1: VIN<2.4V, 0:VIN>2.55V
3:0	R	0x0	Reserved

VSEL0_B Register

Address: (0x06)

Bit	Attr	Reset Value	Description
7:0	R/W	0x30	NSEL0: when VSEL=L option just for DIE_ID=0XA 00,000,000 = 0.5V 00,000,001 = 0.50625V 00,000,010 = 0.51250V 00,110,000 = 0.8V 10,100,000 =1.5V >10,100,000=1.5V

VSEL1_B Register

Address: (0x07)

Bit	Attr	Reset Value	Description
7:0	R/W	0x30	NSEL1: when VSEL=H option just for DIE_ID=0XA 00,000,000 = 0.5V 00,000,001 = 0.50625V 00,000,010 = 0.51250V 00,110,000 = 0.8V 10,100,000 =1.5V >10,100,000=1.5V

Chapter 5 Typical Performance Characteristics

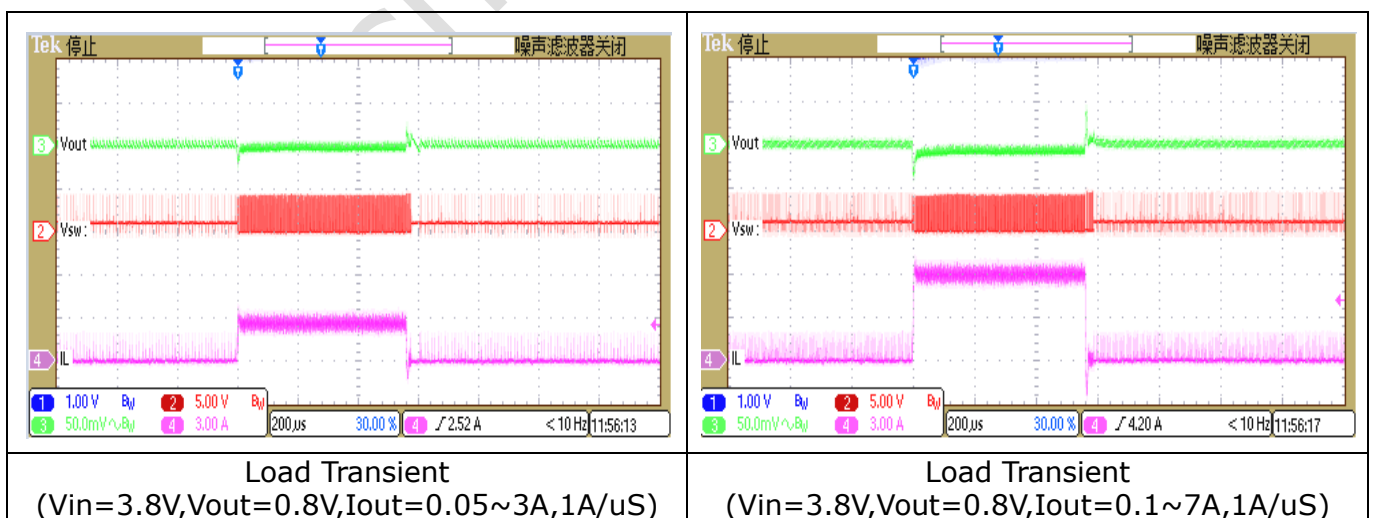
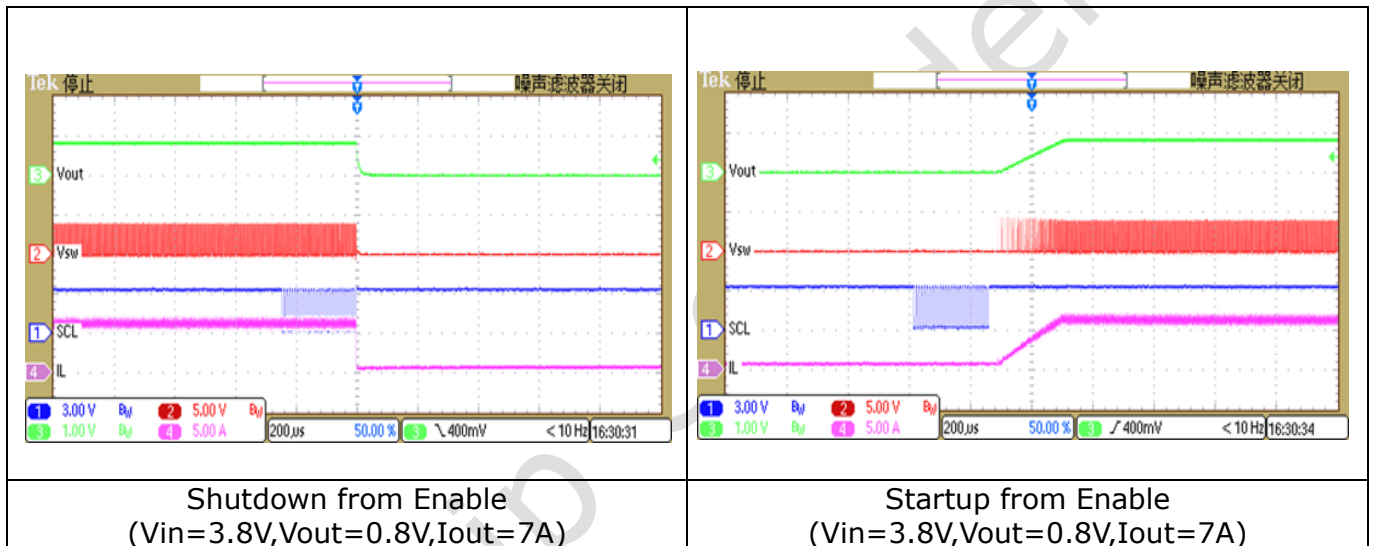
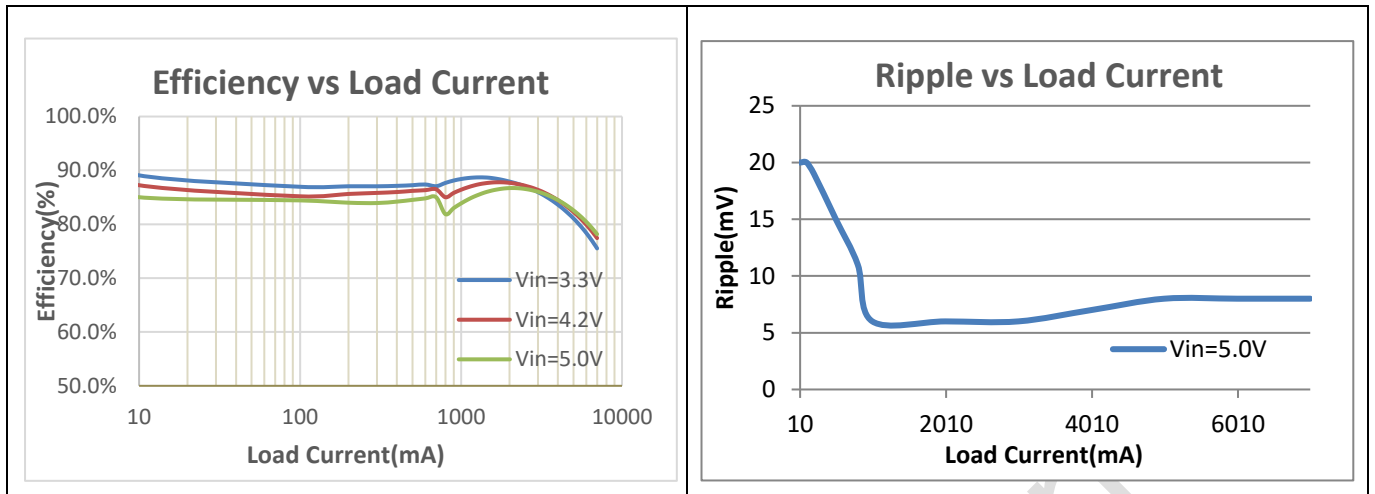

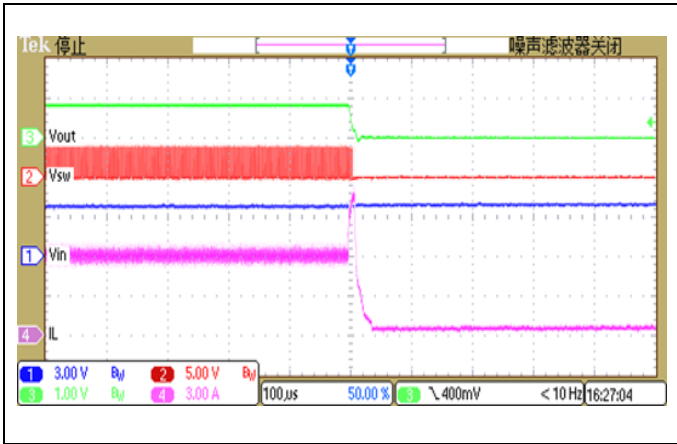

Short Circuit Protection
($V_{in}=3.8V, V_{out}=0.8V, I_{out}=7A \sim \text{short}$)

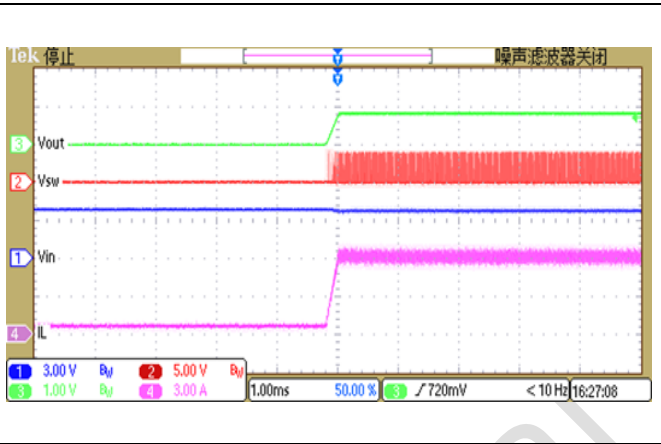

Short Circuit Protection
($V_{in}=3.8V, V_{out}=0.8V, I_{out}=\text{short} \sim 7A$)

Rockchip Confidential

Chapter 6 Package information

6.1 Ordering Information

Orderable Device	Device Mark	RoHS status	Package	Package Qty
RK860M-0	DA	RoHS pass	FCQFN16(pitch 0.85mm)	5000 pcs/tape
RK860M-1	DB	RoHS pass	FCQFN16(pitch 0.85mm)	5000 pcs/tape
RK860M-2	DC	RoHS pass	FCQFN16(pitch 0.85mm)	5000 pcs/tape
RK860M-3	DD	RoHS pass	FCQFN16(pitch 0.85mm)	5000 pcs/tape

6.2 Top Marking

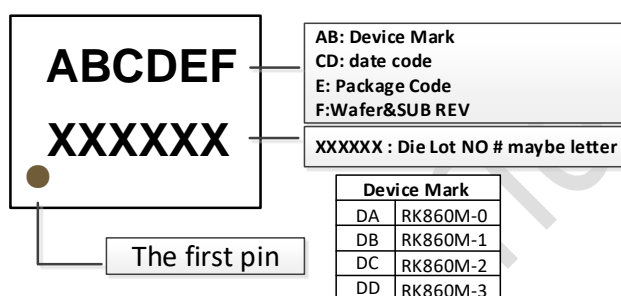

6.3 MSL Information

Moisture sensitivity level: MSL3

6.4 Lead Finish/Pin Material Information

Lead Finish/Pin Material: Sn

6.5 Dimension

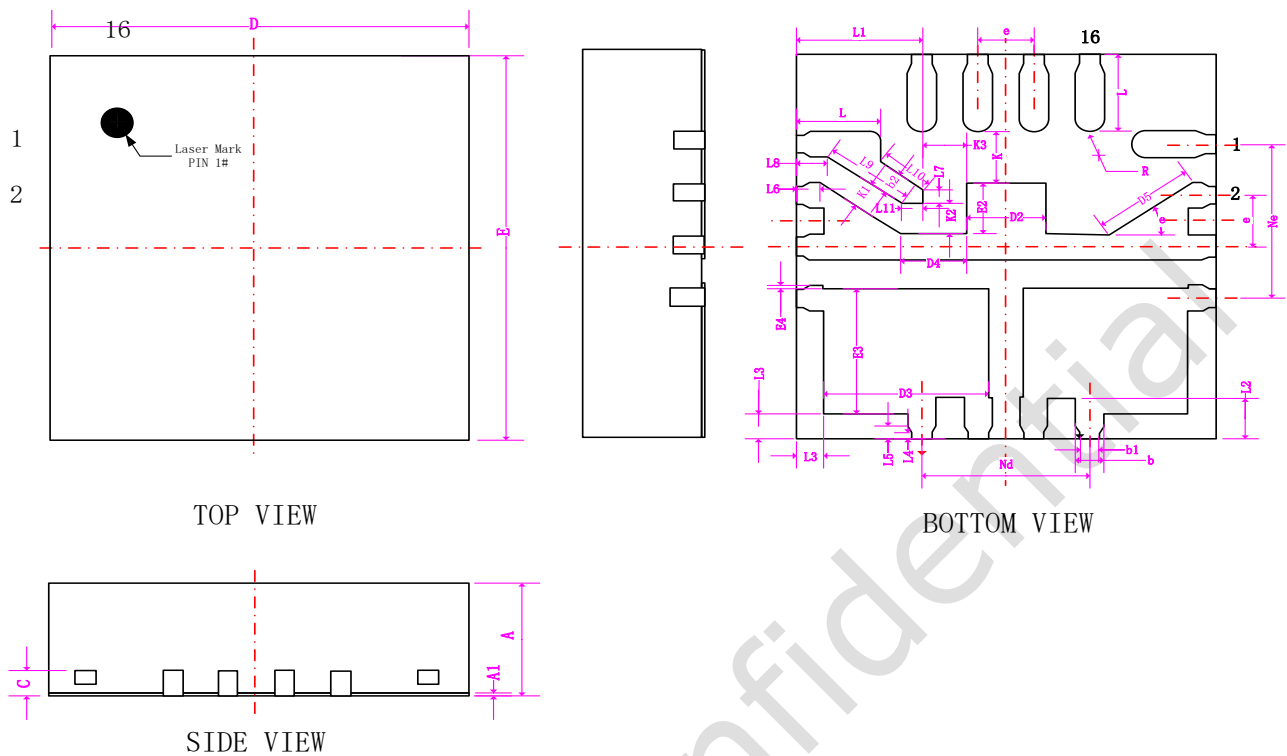

SYMBOL	MILLIMETER			SYMBOL	MILLIMETER			SYMBOL	MILLIMETER		
	MIN	NOM	MAX		MIN	NOM	MAX		MIN	NOM	MAX
A	0.8	0.85	0.9	Nd	1.20BSC			L6	0.163REF		
A1	0	0.02	0.05	Ne	1.20BSC			L7	0.109REF		
b	0.15	0.2	0.25	E	2.9	3	3.1	L8	0.226REF		
b1	0.14REF			E2	0.3	0.4	0.5	L9	0.639REF		
b2	0.13	0.18	0.23	E3	0.875	0.975	1.075	L10	0.377REF		
c	0.203REF			E4	0.025REF			L11	0.158REF		
D	2.9	3	3.1	L	0.55	0.6	0.65	a	35°		
D2	0.48	0.58	0.68	L1	0.81	0.91	1.01	K	0.40REF		
D3	1.075	1.175	1.275	L2	0.325REF			K1	0.20REF		
D4	0.366	0.466	0.566	L3	0.20REF			K2	0.237REF		
D5	0.604	0.704	0.804	L4	0.05REF			K3	0.30REF		
e	0.40BSC			L5	0.10REF			R	0.075REF		

Fig. 6-1 FCQFN16L(03x03X0.85-0.40)

Note:

- Coplanarity applies to leads, corner leads and die attach pad.
- Dimension ϕb applies to metalized terminal and is measured between 0.15mm and 0.30mm from the terminal tip. If the terminal has the optional radius on the other end of the terminal, the dimension ϕb should not be measure in that radius area.
- 0.15mm of dimension ϕb is recommended in PCB layout.

6.6 Layout Recommendation

Reasonable PCB wiring directly affects the performance of the chip. So we need to pay special attention to the following points in PCB Layout.

- The capacitor of VIN and GND must be placed close enough to the pins. To minimize input interference as much as possible.
- The PCB copper area associated with SW pin must be minimized to reduce SW noise.
- The feedback trace connecting Cout to the Vout pin must not be adjacent to the SW

- node on the PCB layout to minimize the noise coupling to VOUT pin.
- To ensure adequate heat dissipation and interference shielding, we must maximize the copper area of the PCB connected to GND. It is recommended to set reasonable through via underneath the ground pad to improve the performance of the circuit loop.
- The GND PAD of the CIN, COUT and Chip must be on the same side (or close enough).
- If your feedback circuit so long and the PCB layout must be follow Fig. 6-3. The capacitor of the C1 must be placed close to the COUT. And the Pin of the VOUT must be connect from the capacitor of the CAP.

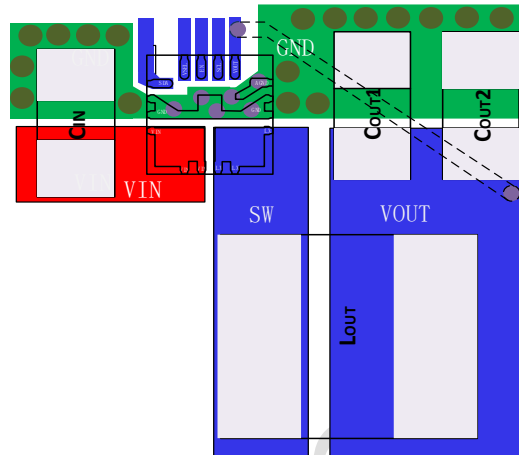

Fig. 6-2 PCB Layout Suggestion

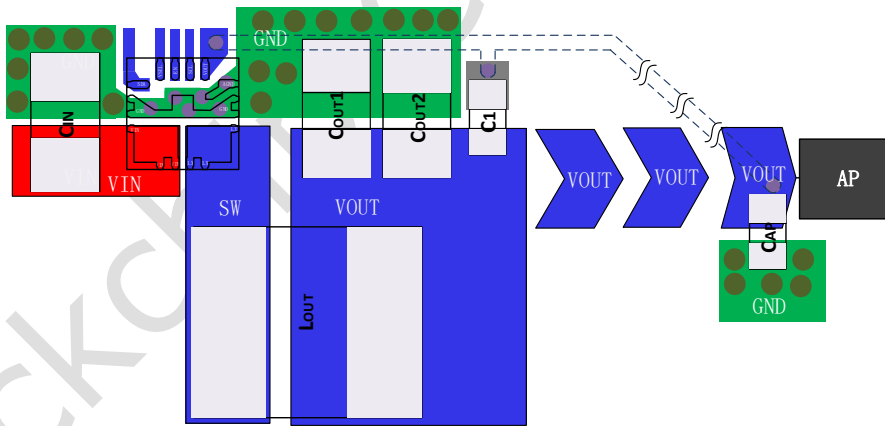

Fig. 6-3 PCB Layout Suggestion

Chapter 7 Thermal Management

7.1 Overview

For reliability and operability concerns, the absolute maximum junction temperature of RK860M has to be below 150°C.

Depending on the thermal mechanical design (Smartphone, Tablet, Personal Navigation Device, etc), the system thermal management software and worst case thermal applications, the junction temperature might be exposed to higher values than those specified above.

Therefore, it is recommended to perform thermal simulations at device level (Smartphone, Tablet, Personal Navigation Device, etc) with the measured power of the worst case UC of the device.

7.2 Package Thermal Characteristics

The following table provides the thermal resistance characteristics for the package used on this device.

Table 7-1 Thermal Resistance Characteristics

PACKAGE (FCQNF)	Continuous power dissipation, PD @ T _A =25°C,FCQFN)	θ _{JA} , 2-layer PCB Thermal resistance from junction to ambient θ _{JA} (°C/W)	θ _{JC} , 2-layer PCB Thermal resistance from junction to component θ _{JC} (°C/W)
RK860M	0.5	64.44	17.76

Table 7-2 SnPb Eutectic Process-Classification Temperatures (T_C)

Package Thickness	Volume mm³ <350	Volume mm³ ≥350
<2.5 mm	235 °C	220°C
≥2.5 mm	220 °C	220°C

Table 7-3 Pb-Free Process-Classification Temperatures (T_C)

Package Thickness	Volume mm³ <350	Volume mm³ 350-2000	Volume mm³ >2000
<1.6 mm	260 °C	260 °C	260°C
1.6 mm-2.5 mm	260°C	250 °C	245°C
>2.5 mm	250 °C	245 °C	245°C

Note 1: At the discretion of the device manufacturer, but not the board assembler/user, the maximum peak package body temperature (T_P) can exceed the values specified in Tables 1-2or 1-3. The use of a higher T_p does not change the classification temperature (T_C).

Note 2: Package volume excludes external terminals (e.g., balls, bumps, lands, leads) and/or nonintegral heat sinks.

Note 3: The maximum component temperature reached during reflow depends on package thickness and volume. The use of convection reflow processes reduces the thermal gradients between packages. However, thermal gradients due to differences in thermal mass of SMD packages may still exist.

Note 4: Moisture sensitivity levels of components intended for use in a Pb-free assembly process shall be evaluated using the Pb-free classification temperatures and profiles defined in Tables 4.2 and 1-4, whether or not Pb-free.

Note 5: SMD packages classified to a given moisture sensitivity level by using Procedures or Criteria defined within any previous version of J-STD-020, JESD22-A112(rescinded), IPC-SM-786 (rescinded) do not need to be reclassified to the current revision unless a change in classification level or a higher peak classification temperature is desired.

Table 7-4 Classification Reflow Profiles

Profile Feature	Sn-Pb Eutectic Assembly	Pb-Free Assembly
Preheat & Soak Temperature min (T _{smin}) Temperature max(T _{smax}) Time (T _{smin} to T _{smax})(ts)	100°C 150°C 60-120 seconds	150°C 200°C 60-120 seconds
Average ramp-up rate (T _{smax} to T _p)	3 °C /second max.	3 °C /second max.
Liquidous temperature (TL) Time at liquidous (tL)	183 °C 60-150 seconds	217 °C 60-150 seconds
Peak package body temperature (T _p)*	See classification temp in Table 1-2	See classification temp in Table 1-3
Time(tp)* * within 5°C of the specified classification temperature (T _c)	20** seconds	30** seconds
Average ramp-down rate (T _p to T _{smax})	6°C /second max.	6 °C /second max.
Time 25 °C to peak temperature	6 minutes max.	8 minutes max.
*Tolerance for peak profile temperature (T _p) is defined as a supplier minimum and a user maximum.		
** Tolerance for time at peak profile temperature (T _p) is defined as a supplier minimum and a user maximum.		

Note 1: All temperatures refer to the center of the package, measured on the package body surface that is facing up during assembly reflow(e.g., live-bug). If parts are reflowed in other than the normal live-bug assembly reflow orientation (i.e., dead-bug), T_p shall be within ±2 °C of the live-bug T_p and still meet the T_c requirements, otherwise, the profile shall be adjusted to achieve the latter. To accurately measure actual peak package body temperatures, refer to JEP140 for recommended thermocouple use.

Note 2: Reflow profiles in this document are for classification/preconditioning and are not meant to specify board assembly profiles. Actual board assembly profiles should be developed based on specific process needs and board designs and should not exceed the parameters in Table 7-4.

For example, if T_c is 260 °C and time T_p is 30 seconds, this means the following for the supplier and the user.

For a supplier. The peak temperature must be at least 260 °C. The time above 255 C must be at least 30 seconds.

For a user: The peak temperature must not exceed 260 °C. The time above 255 °C must not exceed 30 seconds.

Note 3: All components in the test load shall meet the classification profile requirements.

Note 4: SMD packages classified to a given moisture sensitivity level by using Procedures or Criteria defined within any previous version of J-STD-020

JESD22-A112 (rescinded), IPC-SM-786(rescinded) do not need to be reclassified to the current revision unless a change in classification level or a higher peak classification temperature is desired.

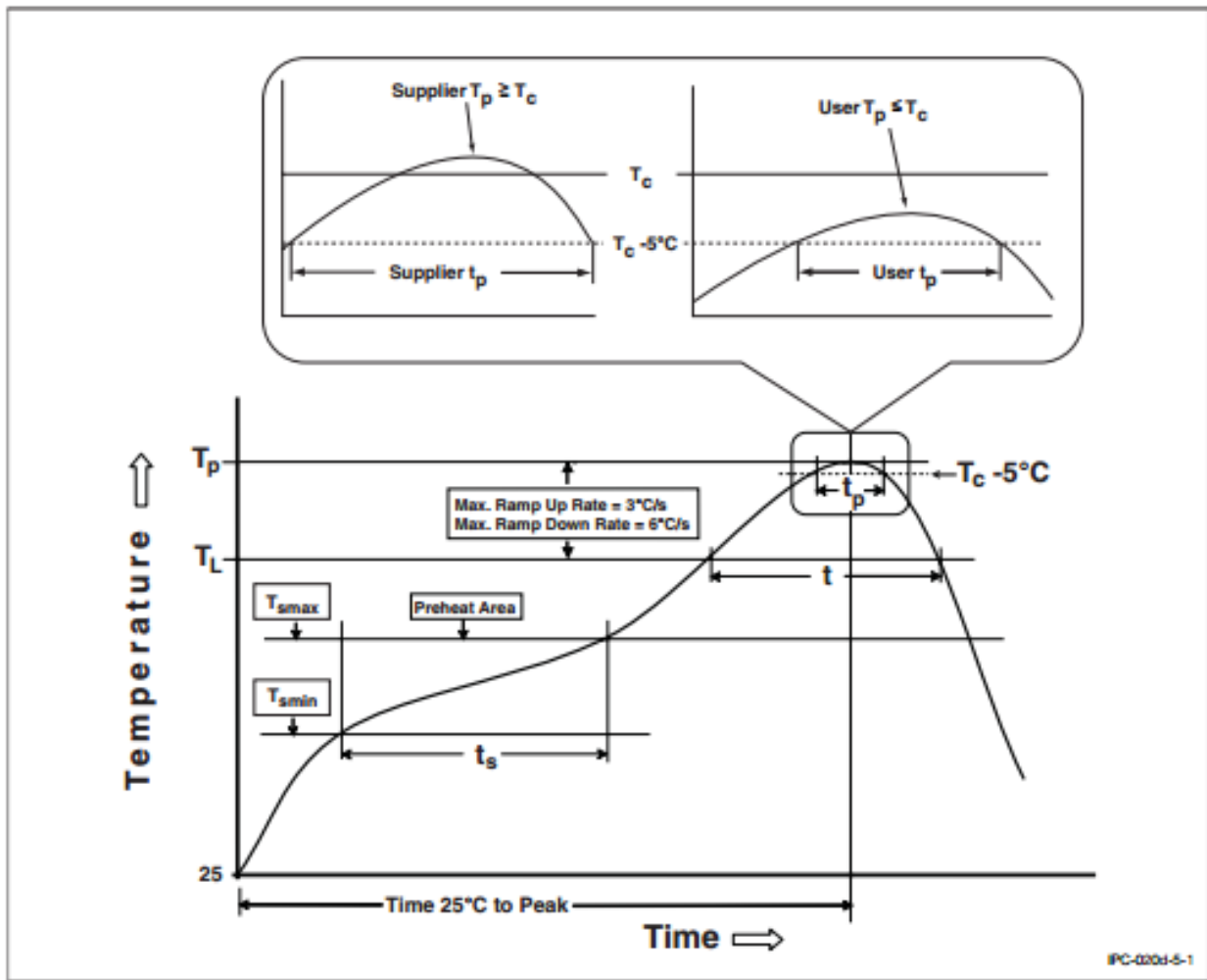

Classification Profile

Rockchip